

Infrastructure-Aided Localization with UWB Antenna Arrays

G. Adamiuk, S. Sczyslo, S. Arafat, W. Wiesbeck, T. Zwick, T. Kaiser and K. Solbach

Abstract – This paper presents an approach for a precise 2D-localization of a mobile station in indoor scenarios using a single base station only. In the approach both, the Direction of Arrival (DoA) and the Time of Arrival (ToA), are estimated using ultra-wideband (UWB) beamformers at both sides of the link. The article describes the algorithm, as well as the required hardware which among these are dual-linear polarized, directive UWB antenna arrays and an UWB-beam-forming network, based on finite impulse response-filters (FIR-filters) which permits the steering of the beamformer.

Index Terms – UWB, Localization, Antennas, Antenna Arrays, Beamforming, FIR-Filter

1 Introduction

Due to their huge bandwidth, ultra-wideband (UWB) signals offer a very high time, and corresponding spatial, resolution [1]. Moreover the immense bandwidth offers high robustness against small scale-fading. As the average EIRP is restricted to approx. 0.5mW according to the FCC-mask [2], UWB devices are endowed to be very energy efficient, but limited in their operation to close-range. Summarized, this means that UWB is an ideal candidate for indoor localization.

Beamformers offer profound spatial filtering [3], so that they can very well be adapted to DoA estimation. By installing beamformers at both sides of a radio link, the sensitivity towards the DoA can even be increased [4].

In the approach presented within this article, UWB and beamforming, are combined in a loosely coupled system, resulting in a 2-D localization system which requires a single base station only. To this the *BeamLoc algorithm*, a novel localization algorithm, is applied which uses electronic beam scan capabilities at the transmitter and the receiver such that ToA and DoA can efficiently be estimated. This paper will give an overview about the proposed localization algorithm and the feasibility of the required hardware.

The paper is arranged as follows: in section 2 the localization algorithm and its advantages in an obstructed line of sight (OLoS) scenario is depicted. Next an array with dual-polarized UWB antennas is presented, followed by section 4 describing the UWB beamformer with the finite impulse response-filter (FIR-filter) technology.

2 Localization Algorithm

The basic idea of the BeamLoc algorithm [5] is deduced from the fact that in a LoS scenario the direction of departure (DoD) and the DoA differ by exactly 180°. This situation, which is called *Locked Mode* in the following, can be exploited by using electronic beam scan devices at the mobile unit and the anchor node. Hence by applying

$$\varphi_{Rx} = \varphi_{Tx} + 180^\circ, \quad (1)$$

the number of possible combinations of steering angles φ_{Tx} and respectively φ_{Rx} , which are possible in a free running system, can significantly be reduced.

It has to be pointed out that this implies, first, the existence of a communication link between the mobile and the anchor, and second a common coordinate system at the mobile and the anchor. The former can be guaranteed since a successful localization requires a minimum of energy at the receiver also, while the second can be realized using magnetic field sensors.

Fig. 1 depicts the operation chart of the complete algorithm: The transmitter adapts its steering angle to $\varphi_{Tx,0}$ and reports it to the receiver using a pulse modulation scheme. Next the receiver adapts its steering angle according to eq. (1). Subsequently the ToA is evaluated based upon the Received Signal Strength Indicator (RSSI) using a matched filter. Both ToA and RSSI are stored together with the corresponding angle information. Next transmitter and receiver adjust to the next angle, such that equation (1) is still fulfilled and the receiver determines the ToA and RSSI for the respective angle. After a full rotation the receiver identifies the Locked Mode using the maximum RSSI and provides the respective DoA and ToA.

Due to the 180° difference of the steering angles the BeamLoc algorithm offers further advantages in an OLoS scenario: Fig. 2 considers the situation for the Locked Mode (Fig.2 left) and a single reflection path (Fig.2 right). It can be observed that only in case of the Locked Mode the gains of both beamformers add to the link budget, compensating partly the attenuation caused by the obstacle. On the contrary in case of the single reflection path (Fig. 2 right), the link budget is increased only by the gain of one beamformer. Thus a DoA estimation becomes possible also in an OLoS scenario. In the Locked Mode the DoA estimation suffers naturally from diffraction. Nevertheless it has been shown in [6], that this error is in the order of 1°-2°, so that the results from the DoA estimation are still of significant use.

It has been shown in [7] that the DoA in an OLoS scenario can be improved due to the fact that the main lobes overlap nearby the direct path. Hence a two dimensional filter enabling a significant increase of the SNR in an OLoS was proposed, which results in an improved estimation of DoA.

As the proposed algorithm requires antennas with strongly directive beams the following section describes the realization using antenna arrays.

3 Dual-orthogonal polarized UWB Antenna Array

Each element of the array consists of two perpendicularly crossed, tapered slot antennas [8]. This allows for the radiation of the signal in two linear, orthogonal polarizations.

In the prototype, four elements are arranged in a linear array. For a fixed spacing of elements, the electrical distance between the elements increases with the frequency across the UWB bandwidth. This causes the generation of grating lobes at higher frequencies, if the spacing is not small enough [9]. The grating lobes may lead to ambiguities in the DoA estimation. One possibility to suppress them is an application of directive antennas in the array with a narrow spacing $d < \lambda$ at the upper frequency band. It has been shown that for the relevant frequency range from 3.1 GHz to 10.6 GHz this

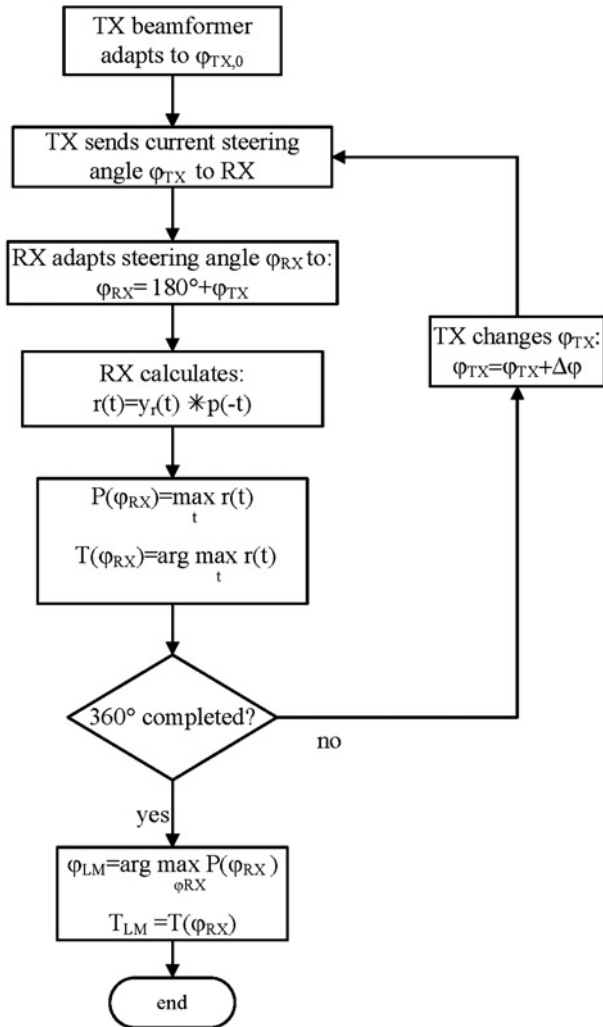

Fig. 1: Flowchart of the BeamLoc algorithm.

distance d should be no greater than 40 mm, when using Vivaldi antennas [10]. However the dimensions of the dual-polarized Vivaldi antenna are too large in order to make them applicable in the antenna arrays for the considered frequency range. For this reason the dual-polarized Vivaldi antennas are embedded in a dielectric, which enables the miniaturization of the transversal dimension of the single antenna to 35 mm (see Fig. 3), while keeping the directive radiation pattern. The design, radiation properties and the suitability of the single antenna for UWB systems are described in [10].

This allows a decrease of the distance between the elements in the array to the respective 35 mm (see Fig. 3). The array is fed through a two-stage, T-junction microstrip power divider and the pattern is measured in an anechoic chamber. The measurements show an equivalent radiation in both polar-

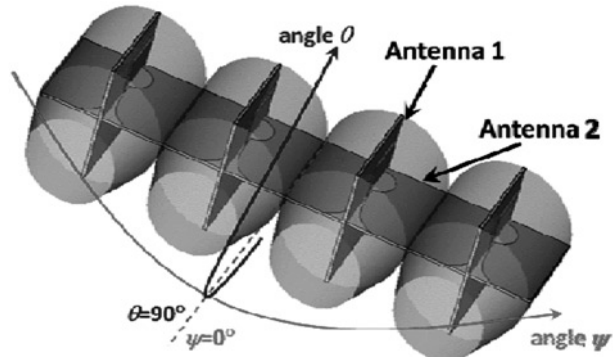

Fig. 3: Schematics of 4x1 dual-polarized, linear antenna array in the coordinate system.

ization states, so that in the following the results are presented for antennas 2 only (see notation in Fig. 3).

The measured mean gain $G_m(\theta, \psi)$ [10] in the E- and H-plane for co- and x-polarization is plotted in Fig. 4. It can clearly be observed that the mean gain in the ψ -plane $G_{m,2}^{E\text{-plane Copol}}(\theta=90^\circ, \psi)$ has a very narrow beam in comparison to the beam in the H-plane $G_{m,2}^{H\text{-plane Copol}}(\theta, \psi=0^\circ)$ confirming the expectations from antenna array theory.

The x-polarization components in both planes $G_{m,2}^{E\text{-plane Xpol}}(\theta=90^\circ, \psi)$, $G_{m,2}^{H\text{-plane Xpol}}(\theta, \psi=0^\circ)$ are suppressed w.r.t. the copolarized by approx. 15 dB in the main beam direction. This allows for the transmission and reception of an arbitrary polarized signal within the main beam. Remarkable is the higher mean gain in the H-plane $G_{m,2}^{H\text{-plane Copol}}(\theta, \psi=0^\circ)$ far off the main beam. This is due to the radiation from the unshielded power divider, which shows its whole aperture along the θ -plane (H-plane in Fig. 4). In the final feeding network where FIR-filter control circuits are integrated, this effect can be minimized through a proper shielding.

The introduced antenna array and its measurement results show a suitability of the device in the proposed 2D localization system, where a polarimetric radiation with very narrow beam width is desired. As the algorithm requires the steering of the pattern, the subsequent section shows a possible realization using a FIR-filter.

4 FIR-Filter Control Circuits for UWB Beamforming

In conventional narrowband beamforming, the phases of the signals at each antenna element are shifted before summation. The phase shifts are chosen such that they steer the beam to the desired direction. However this method enables the desired scan only for a single frequency [11]. For instantaneous broadband signals the phase shifters can be replaced by true-time delay elements (TTD), where the phase varies linearly with frequency [12] to keep the beam direction fixed.

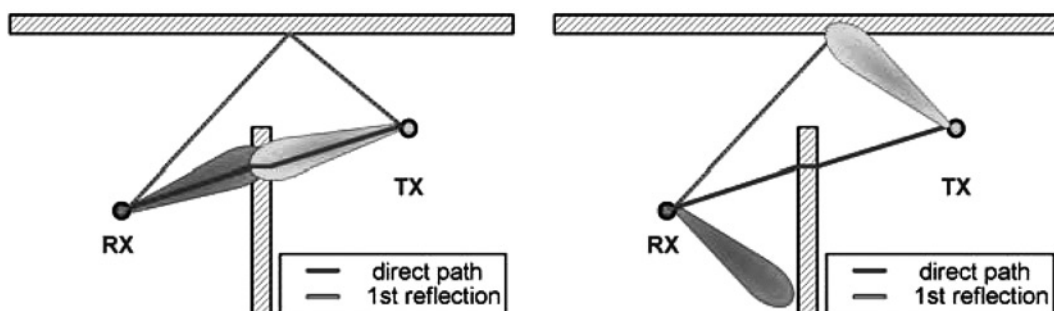

Fig. 2: BeamLoc algorithm in Locked Mode (left); BeamLoc algorithm pointing at a single reflection (right).

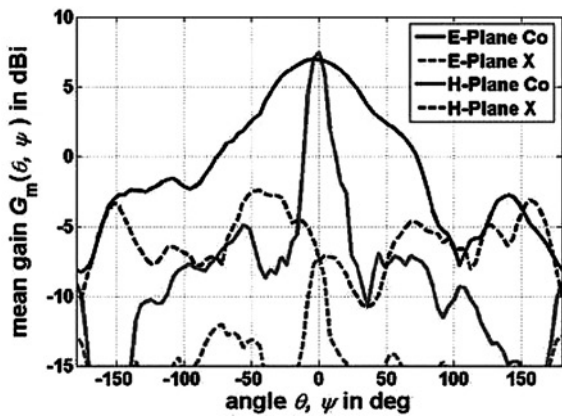

Fig. 4: Measured mean gain $G_{m,2}(\theta, \psi)$ in E- and H-plane, in co- and x-polarization for the antenna array 2 (cf. Fig. 3).

This technique still results in a shift of nulls and a widening of the main beam in dependency of the frequency. Therefore the aim is to create frequency independent beam patterns using suitable array weightings. A promising solution regarding the practical realization for the microwave frequency range is based on finite impulse response (FIR)-filtering. Each FIR-filter causes a frequency dependent phase and amplitude response which can be used for frequency independent beamforming and additionally for the cancellation and equalization of undesired antenna and channel effects [11, 13].

The FIR filters as an analog microwave circuit have been investigated in the literature only theoretically. The authors presented the first designs, which were based on dual-gate FET circuits for 180° phase splitting and voltage controlled amplification at a scaled down frequency range [14]. Both functions combine to realize the amplitude weighting stages (factor a_i) of the FIR-filter, which require bi-phase variable attenuators ($-1 \leq a_i \leq 1$). For the FCC UWB-bandwidth design the bi-phase converter uses a passive bi-phase power divider at the input ($x(t)$, left in Fig. 5), which provides two lines for equal amplitude and 180° out of phase signals [15]. The variable attenuators are realized by implementing monolithic integrated voltage variable attenuator (VVA) circuits to transfer signals from one of the input lines into the output line ($y(t)$, right in Fig.5). The attenuation of each stage can be varied according to the required weighting coefficients, which are calculated with respect to the constraints using optimization techniques like the least squares method or convex optimization. On both input signal lines and on the output signal line the travelling waves are assumed, which require that the input and output of the weighting stages have high impedance and thereby avoid heavy loading of the transmission lines. Therefore, the broadband matching of the weighting stages is one critical issue for the multi-stage filter design.

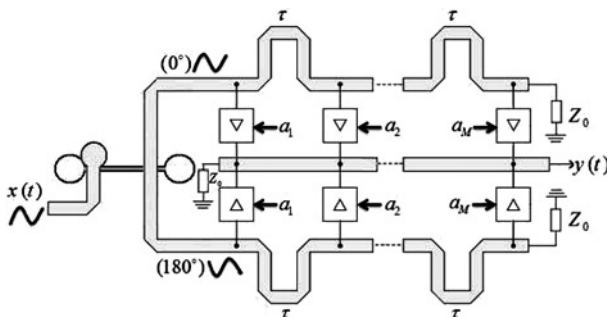

Fig. 5: Design of an analogue FIR filter for FCC UWB frequency bandwidth

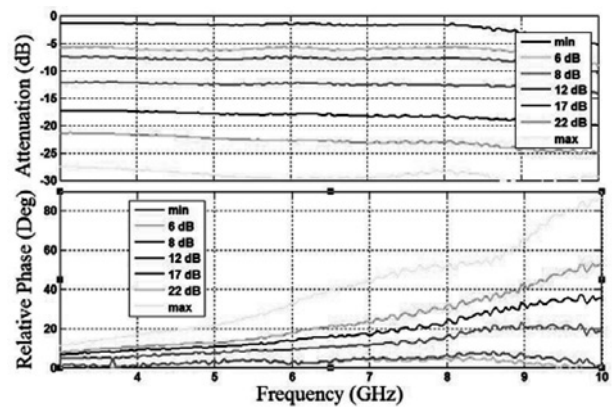

Fig. 6: Measured relative amplitude and phase under different attenuation states

The second principal issue is the realization of linear phase and constant amplitude versus frequency under any attenuation state. The unavoidable amplitude-to-phase conversion in the VVA stages (Fig. 6), results in a slight variation of delay of that stage. For the approximate compensation of this degradation, the algorithm for the FIR filter coefficient calculation has to be modified, so that the combination of all (degraded) stages produces the optimum response.

5 Conclusions

In this paper an approach for a very precise and highly robust localization system was introduced. The proposed algorithm, which is based on the application of electronically steered, dual-orthogonally polarized UWB antenna arrays, was explained and its advantages towards conventional ToA techniques were highlighted. The feasibility of the antennas with the given requirements was shown by measurements of a prototype. The design of analog FIR-filters for UWB electronic beam steering was presented. The system can be applied in e.g. emergency applications for the improvement of the security of the rescuers or better coordination of the rescue action.

References

- [1] S. Gezici, Zhi Tian, G.B Giannakis, H. Kobayashi, A.F. Molisch, H.V. Poor, and Z. Sahinoglu, "Localization via ultra-wideband radios: a look at positioning aspects for future sensor networks", *IEEE Signal Processing Magazine*, vol. 22, issue 4, pp. 70–84, July 2005
- [2] FCC, Revision of Part 15 of the commission's rules regarding ultra wideband transmission systems, ET Docket 98–153, FCC 02–48, Feb. 14, 2002
- [3] B.D. Van Veen, and K.M. Buckley, "Beamforming: a versatile approach to spatial filtering", *IEEE Microwave Acoustics, Speech and Signal Processing Magazine*, vol. 5, no. 2, April 1988
- [4] H. Tsuchiya, K. Haneda and J. Takada, "Investigation of an Ultra-Wideband Propagation Channel based on a Cluster Scheme", *IEICE Trans. Fundamentals*, Vol.E89-A, no. 11, November 2006
- [5] C. Senger and T. Kaiser, "Beamloc – An Approach for NLOS Localization in UWB Indoor Environments", *Seminar on Ultra Wideband Systems, Technologies and Applications*, Calgary, 2006
- [6] A. Safaai-Jazi, S. M. Riad, A. Muqaibel, and A. Bayram, "Through-the-Wall Propagation and Material Characterization", *Tech. Report DARPA NETEX Program*, November 2002
- [7] S. Sczyslo, C. Senger, and T. Kaiser, "A 2-Dimensional Filter for UWB-Localization in NLoS Scenarios using BeamLoc", *Proceedings of 6th Workshop on Positioning, Navigation and Communication WPNC 2009*, Hannover, 2009
- [8] G. Adamiuk, T. Zwick and W. Wiesbeck, "Dual-orthogonal polarized Vivaldi Antenna for Ultra Wideband Applications", *17th International Conference on Microwaves, Radar & Wireless Communications*, 2008. MIKON 2008, Wroclaw, Poland, 19–21 May 2008

- [9] W. Sörgel, C. Sturm and W. Wiesbeck, “Impulse responses of linear UWB antenna arrays and the application to beamsteering”, *IEEE International Conference on Ultra-Wideband ICU 2005*, pp. 275–280, 5–8 September 2005
- [10] G. Adamiuk, W. Wiesbeck, and T. Zwick, “Compact, Dual-Polarized UWB Antenna, Embedded in a Dielectric”, *IEEE Transactions on Antennas and Propagation* (accepted for publication)
- [11] M. Neinhüs, M. El-Hadidy, S. Held, T. Kaiser, and K. Solbach, “An ultra wideband linear array beamforming concept considering antenna and channel effects”, *European Conference on Antennas and Propagation*, Nice, France, Nov. 2006
- [12] B. Allen and M. Ghavami, “Adaptive array systems -fundamentals and applications”, John Wiley & Sons, Inc., 2005
- [13] M. Neinhüs, S. Held, and K. Solbach, “FIR-filter based equalization of ultra wideband mutual coupling on linear antenna arrays”, *2nd International ITG Conference on Antennas*, Munich, 28–30 March 2007
- [14] K. Solbach, T. Ould Mohamed, M. Neinhüs, and M. Tekloth, “Microwave analogue FIR-filter”, *German Microwave Conference GeMIC 2005*, Ulm, April 2005
- [15] M. E. Bialkowski and A. M. Abbosh, “Design of a Compact UWB Out-of-Phase Power Divider,” *IEEE Microwave and Wireless Components Letters*, vol. 17, no. 4, April 2007

Grzegorz Adamiuk,
Werner Wiesbeck,
Thomas Zwick
Institut für Hochfrequenztechnik und Elektronik (IHE)
Karlsruher Institut für Technologie (KIT)
Kaiserstr. 12, 76128, Karlsruhe, Germany
Email: grzegorz.adamiuk@ihe.uka.de

Sebastian Sczyslo,
Thomas Kaiser
Institut für Kommunikationstechnik (IKT)
Leibniz Universität Hannover
Appelstr. 9A, 30167, Hannover, Germany
Email: sebastian.szcyslo@ikt.uni-hannover.de

Saeed Arafat,
Klaus Solbach
Lehrstuhl für Hochfrequenztechnik
Universität Duisburg – Essen
Bismarckstraße 81, 47051, Duisburg, Germany
Email: saeed.arafat@uni-duisburg-essen.de

The authors would like to thank the German Research Foundation (DFG) for the support of this project.