

**Shear correction factors
in Timoshenko's beam theory
for arbitrary shaped cross-sections**

F. Gruttmann, W. Wagner

Mitteilung 6(2001)

**Shear correction factors
in Timoshenko's beam theory
for arbitrary shaped cross-sections**

F. Gruttmann, W. Wagner

Mitteilung 6(2001)

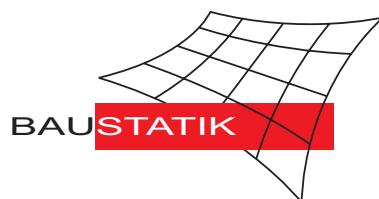

Shear correction factors in Timoshenko's beam theory for arbitrary shaped cross-sections

F. Gruttmann
Institut für Statik
Technische Universität Darmstadt
Alexanderstraße 7
64283 Darmstadt
Germany

W. Wagner
Institut für Baustatik
Universität Karlsruhe (TH)
Kaiserstraße 12
76131 Karlsruhe
Germany

Abstract In this paper shear correction factors for arbitrary shaped beam cross-sections are calculated. Based on the equations of linear elasticity and further assumptions for the stress field the boundary value problem and a variational formulation are developed. The shear stresses are obtained from derivatives of the warping function. The developed element formulation can easily be implemented in a standard finite element program. Continuity conditions which occur for multiple connected domains are automatically fulfilled.

1 Introduction

The problem of torsional and flexural shearing stresses in prismatic beams has been studied in several papers. Here, publications in [1, 2, 3] are mentioned among others. Furthermore the text books of e.g. Timoshenko and Goodier [4] or Sokolnikoff [5] give detailed representations of the topics. A finite element formulation has been discussed by Mason and Herrmann [6]. Based on assumptions for the displacement field and exploiting the principle of minimum potential energy triangular finite elements are developed. Zeller [7] evaluates warping of beam cross-sections subjected to torsion and bending.

In the present paper shear correction factors for arbitrary shaped cross-sections using the finite element method are evaluated. The considered rod is subjected to torsionless bending. Different definitions on this term have been introduced in the literature, see Timoshenko and Goodier [4]. Here we follow the approach of Trefftz [3], where uncoupling of the strain energy for torsion and bending is assumed. The essential features and novel aspects of the present formulation are summarized as follows.

All basic equations are formulated with respect to an arbitrary cartesian coordinate system which is not restricted to principal axes. Thus the origin of this system is not necessarily a special point like the centroid. This relieves the input of the finite element data. Based on the equilibrium and compatibility equations of elasticity and further assumptions for the stress field the weak form of the boundary value problem is derived. The shear stresses are obtained from derivatives of a warping function. The essential advantage compared with stress functions introduced by other authors, like Schwalbe [2], Weber [1] or Trefftz [3]

is the fact that the present formulation is also applicable to multiple connected domains without fulfilment of further constraints. Within the approach of [2, ?, 3] the continuity conditions yield additional constraints for cross sections with holes. In contrast to a previous paper [8] the present formulation leads to homogeneous Neumann boundary conditions. This simplifies the finite element implementation and reduces the amount of input data in a significant way. Within our approach shear correction factors are defined comparing the strain energies of the average shear stresses with those obtained from the equilibrium. Other definitions are discussed in the paper. The computed quantities are necessary to determine the shear stiffness of beams with arbitrary cross-sections.

2 Torsionless bending of a prismatic beam

We consider a rod with arbitrary reference axis x and section coordinates y and z . The parallel system $\bar{y} = y - y_S$ and $\bar{z} = z - z_S$ intersects at the centroid. According to Fig. 1 the domain is denoted by Ω and the boundary by $\partial\Omega$. The tangent vector \mathbf{t} with associated coordinate s and the outward normal vector $\mathbf{n} = [n_y, n_z]^T$ form a right-handed system. In the following the vector of shear stresses $\boldsymbol{\tau} = [\tau_{xy}, \tau_{xz}]^T$ due to bending is derived from the theory of linear elasticity. For this purpose we summarize some basic equations of elasticity.

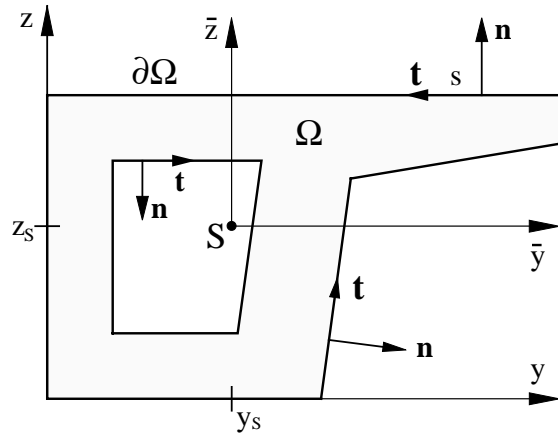

Fig. 1: Cross-section of a prismatic beam

The equilibrium equations neglecting body forces read

$$\begin{aligned} \sigma_{x,x} + \tau_{xy,y} + \tau_{xz,z} &= 0 \\ \sigma_{y,y} + \tau_{yz,z} + \tau_{xy,x} &= 0 \\ \sigma_{z,z} + \tau_{xz,x} + \tau_{yz,y} &= 0, \end{aligned} \quad (1)$$

where commas denote partial differentiation. Furthermore, the compatibility conditions in terms of stresses have to be satisfied

$$\begin{aligned} (1 + \nu)\Delta\sigma_x + s_{,xx} &= 0 & (1 + \nu)\Delta\tau_{yz} + s_{,yz} &= 0 \\ (1 + \nu)\Delta\sigma_y + s_{,yy} &= 0 & (1 + \nu)\Delta\tau_{xy} + s_{,xy} &= 0 \\ (1 + \nu)\Delta\sigma_z + s_{,zz} &= 0 & (1 + \nu)\Delta\tau_{xz} + s_{,xz} &= 0. \end{aligned} \quad (2)$$

Here, Δ denotes the Laplace operator, ν is Poisson's ratio, and $s = \sigma_x + \sigma_y + \sigma_z$, respectively.

We proceed with assumptions for the stress field. The shape of the normal stresses σ_x is given according to the elementary beam theory, thus linear with respect to \bar{y} and \bar{z} . The stresses σ_y, σ_z and τ_{yz} are neglected. The transverse shear stresses follow from derivatives of the warping function $\varphi(y, z)$. Thus, it holds

$$\begin{aligned}\sigma_x &= a_y(x)\bar{y} + a_z(x)\bar{z} \\ \sigma_y &= \sigma_z = \tau_{yz} = 0 \\ \tau_{xy} &= \varphi_{,y} - f_1 \\ \tau_{xz} &= \varphi_{,z} - f_2\end{aligned}\tag{3}$$

where we assume that a_y and a_z are linear functions of x . Furthermore the functions

$$f_1(z) = -\frac{\nu}{2(1+\nu)}a'_y(z - z_0)^2 \quad f_2(y) = -\frac{\nu}{2(1+\nu)}a'_z(y - y_0)^2.\tag{4}$$

are specified, where $()'$ denotes the derivative with respect to x . Using a definition for torsionless bending the constants y_0 and z_0 are derived in the appendix. As is shown in this section considering the functions $f_1(z)$ and $f_2(y)$ one obtains a differential equation by which the equilibrium and compatibility equations can be advantageously combined. The rod is stress free along the cylindrical surface which yields the boundary condition

$$\tau_{xy} n_y + \tau_{xz} n_z = 0.\tag{5}$$

Next, the derivative of the normal stresses $\sigma_{x,x} := f_0(y, z)$ reads

$$f_0(y, z) = a'_y \bar{y} + a'_z \bar{z}.\tag{6}$$

The unknown constants a'_y and a'_z are determined with

$$Q_y = \int_{(\Omega)} \tau_{xy} \, dA \quad Q_z = \int_{(\Omega)} \tau_{xz} \, dA.\tag{7}$$

The integral of the shear stresses τ_{xy} considering (1)₁ and applying integration by parts yields

$$\begin{aligned}\int_{(\Omega)} \tau_{xy} \, dA &= \int_{(\Omega)} [\tau_{xy} + \bar{y}(\tau_{xy,y} + \tau_{xz,z} + f_0)] \, dA \\ &= \int_{(\Omega)} [(\bar{y}\tau_{xy})_{,y} + (\bar{y}\tau_{xz})_{,z}] \, dA + \int_{(\Omega)} \bar{y} f_0 \, dA \\ &= \oint_{(\partial\Omega)} \bar{y} (\tau_{xy} n_y + \tau_{xz} n_z) \, ds + \int_{(\Omega)} \bar{y} f_0 \, dA.\end{aligned}\tag{8}$$

The boundary integral vanishes considering (5). Thus, inserting eq. (6) we obtain

$$\int_{(\Omega)} \tau_{xy} \, dA = \int_{(\Omega)} \bar{y}(a'_y \bar{y} + a'_z \bar{z}) \, dA.\tag{9}$$

In an analogous way the integral of the shear stresses τ_{xz} can be reformulated. Hence, using the notation $A_{ab} = \int_{(\Omega)} ab \, dA$ eqs. (7) leads to the system of equations

$$\begin{bmatrix} A_{\bar{y}\bar{y}} & A_{\bar{y}\bar{z}} \\ A_{\bar{y}\bar{z}} & A_{\bar{z}\bar{z}} \end{bmatrix} \begin{bmatrix} a'_y \\ a'_z \end{bmatrix} = \begin{bmatrix} Q_y \\ Q_z \end{bmatrix} \quad (10)$$

for the unknowns a'_y and a'_z . The solution yields

$$a'_y = \frac{Q_y A_{\bar{z}\bar{z}} - Q_z A_{\bar{y}\bar{z}}}{A_{\bar{y}\bar{y}} A_{\bar{z}\bar{z}} - A_{\bar{y}\bar{z}}^2} \quad a'_z = \frac{Q_z A_{\bar{y}\bar{y}} - Q_y A_{\bar{y}\bar{z}}}{A_{\bar{y}\bar{y}} A_{\bar{z}\bar{z}} - A_{\bar{y}\bar{z}}^2}. \quad (11)$$

Considering (3) one can easily verify that the compatibility conditions (2)₁ – (2)₄ are identically fulfilled. The last two equations of (2) can be reformulated as follows

$$\begin{aligned} (1 + \nu) \Delta \tau_{xy} + s_{,xy} &= (1 + \nu) \left(\Delta \varphi_{,y} + \frac{\nu}{1 + \nu} a'_y \right) + a'_y = 0 \\ (1 + \nu) \Delta \tau_{xz} + s_{,xz} &= (1 + \nu) \left(\Delta \varphi_{,z} + \frac{\nu}{1 + \nu} a'_z \right) + a'_z = 0, \end{aligned} \quad (12)$$

or

$$\Delta \varphi_{,y} + a'_y = 0 \quad \Delta \varphi_{,z} + a'_z = 0. \quad (13)$$

The solution of the Poisson equation $\Delta \varphi + f_0 = 0$ fulfills (13). This differential equation also follows when inserting (3) into the equilibrium (1)₁.

Hence, the resulting boundary value problem follows from (1)₁ and (5)

$$\tau_{xy,y} + \tau_{xz,z} + f_0(y, z) = 0 \quad \text{in } \Omega \quad \tau_{xy} n_y + \tau_{xz} n_z = 0 \quad \text{on } \partial\Omega. \quad (14)$$

The solution of (14) using (3) satisfies the equations of three-dimensional elasticity (1) and (2) altogether.

The associated weak form is obtained weighting the differential equation with test functions $\eta \in H^1(\Omega)$ and integrating over the domain

$$g(\varphi, \eta) = - \int_{(\Omega)} [\tau_{xy,y} + \tau_{xz,z} + f_0(y, z)] \eta \, dA = 0. \quad (15)$$

Integration by parts yields

$$g(\varphi, \eta) = \int_{(\Omega)} [\tau_{xy} \eta_{,y} + \tau_{xz} \eta_{,z} - f_0(y, z) \eta] \, dA - \oint_{(\partial\Omega)} (\tau_{xy} n_y + \tau_{xz} n_z) \eta \, ds = 0, \quad (16)$$

where the boundary integral considering (14)₂ vanishes. Inserting the shear stresses using (3) we obtain

$$g(\varphi, \eta) = \int_{(\Omega)} [\varphi_{,y} \eta_{,y} + \varphi_{,z} \eta_{,z}] \, dA - \int_{(\Omega)} [f_0 \eta + f_1 \eta_{,y} + f_2 \eta_{,z}] \, dA = 0 \quad (17)$$

which completes the variational formulation.

3 Shear correction factors

There are several definitions of the shear correction factor κ , see e.g. Cowper [9] for a review. According to the work of Timoshenko κ is the ratio of the average shear strain on a section to the shear strain at the centroid. The analysis which leads to this definition is given in [10]. However, several authors have pointed out that one obtains unsatisfactory results when Timoshenko's beam equations and above defined shear correction factor are used to calculate the high-frequency spectrum of vibrating beams, [9]. Thus, further research on this problem has been done. The influence of transverse loading and of support on the shear deformation has been studied e.g. by Stojek [11], Cowper [9] or Mason and Herrmann [6].

Here, we follow the approach of Bach [12] and Stojek [11] using the balance of energy of the beam for linear elasticity

$$\frac{1}{2}F\delta = \frac{1}{2} \int_{(x)} \int_{(\Omega)} \left(\frac{\sigma_x^2}{E} + \frac{\tau_{xy}^2 + \tau_{xz}^2}{G} \right) dA dx. \quad (18)$$

The left-hand side describes the work of the external force F acting on the considered beam such that bending without torsion occurs and δ is the unknown displacement projection of the loading point. Furthermore, E and G denote Young's modulus and shear modulus, respectively. Eq. (18) shows, that δ depends on the distribution of the normal stresses σ_x and the shear stresses τ_{xy} and τ_{xz} .

In the following the shear terms are reformulated. First, we introduce the average shear stresses by

$$\bar{\tau}_{xy} = \frac{Q_y}{A_{sy}} \quad \bar{\tau}_{xz} = \frac{Q_z}{A_{sz}} \quad (19)$$

where the so-called shear areas are related to the area of the considered cross-section A by

$$A_{sy} = \kappa_y A \quad A_{sz} = \kappa_z A. \quad (20)$$

The shear correction factors κ_y and κ_z are defined comparing the strain energies and considering (19) and (20)

$$\int_{(\Omega)} (\tau_{xy}^2 + \tau_{xz}^2) dA = \int_{(\Omega_{sy})} \bar{\tau}_{xy}^2 dA_{sy} + \int_{(\Omega_{sz})} \bar{\tau}_{xz}^2 dA_{sz} = \alpha_y \frac{Q_y^2}{A} + \alpha_z \frac{Q_z^2}{A} \quad (21)$$

with $\alpha_y = 1/\kappa_y$ and $\alpha_z = 1/\kappa_z$. Reformulation of the left-hand side yields with (3) and integration by parts

$$\begin{aligned} & \int_{(\Omega)} (\tau_{xy}^2 + \tau_{xz}^2) dA \\ &= \int_{(\Omega)} (\tau_{xy} \varphi_{,y} + \tau_{xz} \varphi_{,z}) dA - \int_{(\Omega)} (\tau_{xy} f_1 + \tau_{xz} f_2) dA \\ &= - \int_{(\Omega)} (\tau_{xy,y} + \tau_{xz,z}) \varphi dA + \oint_{(\partial\Omega)} (\tau_{xy} n_y + \tau_{xz} n_z) \varphi ds - \int_{(\Omega)} (\tau_{xy} f_1 + \tau_{xz} f_2) dA. \end{aligned} \quad (22)$$

The boundary integral vanishes when considering (14)₂. Furthermore we insert (14)₁, (6) and (4)

$$\begin{aligned} \int_{(\Omega)} (\tau_{xy}^2 + \tau_{xz}^2) dA &= \int_{(\Omega)} f_0 \varphi dA - \int_{(\Omega)} (\tau_{xy} f_1 + \tau_{xz} f_2) dA \\ &= a'_y (A_{\varphi\bar{y}} + \frac{\nu}{2(1+\nu)} C_{zz}) + a'_z (A_{\varphi\bar{z}} + \frac{\nu}{2(1+\nu)} C_{yy}) \end{aligned} \quad (23)$$

where

$$C_{yy} = \int_{(\Omega)} \tau_{xz} (y - y_0)^2 dA \quad C_{zz} = \int_{(\Omega)} \tau_{xy} (z - z_0)^2 dA. \quad (24)$$

Inserting (11) into (23) and the result with (19) into (21) yields

$$\begin{aligned} Q_y & \left[\frac{A_{\varphi\bar{y}} A_{\bar{z}\bar{z}} - A_{\varphi\bar{z}} A_{\bar{y}\bar{z}}}{A_{\bar{y}\bar{y}} A_{\bar{z}\bar{z}} - A_{\bar{y}\bar{z}}^2} + \frac{\nu}{2(1+\nu)} \frac{(C_{zz} A_{\bar{z}\bar{z}} - C_{yy} A_{\bar{y}\bar{z}})}{(A_{\bar{y}\bar{y}} A_{\bar{z}\bar{z}} - A_{\bar{y}\bar{z}}^2)} - \alpha_y \frac{Q_y}{A} \right] \\ + Q_z & \left[\frac{A_{\varphi\bar{z}} A_{\bar{y}\bar{y}} - A_{\varphi\bar{y}} A_{\bar{y}\bar{z}}}{A_{\bar{y}\bar{y}} A_{\bar{z}\bar{z}} - A_{\bar{y}\bar{z}}^2} + \frac{\nu}{2(1+\nu)} \frac{(C_{yy} A_{\bar{y}\bar{y}} - C_{zz} A_{\bar{y}\bar{z}})}{(A_{\bar{y}\bar{y}} A_{\bar{z}\bar{z}} - A_{\bar{y}\bar{z}}^2)} - \alpha_z \frac{Q_z}{A} \right] = 0. \end{aligned} \quad (25)$$

By letting $Q_z = 0$ we obtain α_y and with $Q_y = 0$ we obtain α_z as

$$\begin{aligned} \alpha_y &= \frac{A}{Q_y} \left[\frac{A_{\varphi\bar{y}} A_{\bar{z}\bar{z}} - A_{\varphi\bar{z}} A_{\bar{y}\bar{z}}}{A_{\bar{y}\bar{y}} A_{\bar{z}\bar{z}} - A_{\bar{y}\bar{z}}^2} + \frac{\nu}{2(1+\nu)} \frac{(C_{zz} A_{\bar{z}\bar{z}} - C_{yy} A_{\bar{y}\bar{z}})}{A_{\bar{y}\bar{y}} A_{\bar{z}\bar{z}} - A_{\bar{y}\bar{z}}^2} \right] \\ \alpha_z &= \frac{A}{Q_z} \left[\frac{A_{\varphi\bar{z}} A_{\bar{y}\bar{y}} - A_{\varphi\bar{y}} A_{\bar{y}\bar{z}}}{A_{\bar{y}\bar{y}} A_{\bar{z}\bar{z}} - A_{\bar{y}\bar{z}}^2} + \frac{\nu}{2(1+\nu)} \frac{(C_{yy} A_{\bar{y}\bar{y}} - C_{zz} A_{\bar{y}\bar{z}})}{A_{\bar{y}\bar{y}} A_{\bar{z}\bar{z}} - A_{\bar{y}\bar{z}}^2} \right]. \end{aligned} \quad (26)$$

Using (26) the shear stiffness parameters $GA_{s_y} = GA/\alpha_y$ and $GA_{s_z} = GA/\alpha_z$ in Timoshenko's beam theory are defined. In our approach α_y and α_z are pure shape factors and do not consider e.g. the influence of the transverse loading or the support.

4 Finite element formulation

The weak form of the boundary value problem (17) is solved approximately using the finite element method. Since only derivatives of first order occur, C^0 -continuous elements can be used for the finite element discretization. Applying an isoparametric concept the coordinates $\mathbf{x} = [y, z]^T$, the warping function φ and the test function η are interpolated as follows

$$\mathbf{x}^h = \sum_{I=1}^{nel} N_I(\xi, \eta) \mathbf{x}_I \quad \varphi^h = \sum_{I=1}^{nel} N_I(\xi, \eta) \varphi_I \quad \eta^h = \sum_{I=1}^{nel} N_I(\xi, \eta) \eta_I, \quad (27)$$

where nel denotes the number of nodes per element. The index h is used to denote the approximate solution of the finite element method. The derivatives of the shape functions $N_I(\xi, \eta)$ with respect to y and z are obtained in a standard way using the chain rule. Inserting the derivatives of φ^h and η^h into the weak form (17) yields the finite element equation

$$g(\varphi^h, \eta^h) = \mathbf{A} \sum_{e=1}^{numel} \sum_{I=1}^{nel} \sum_{K=1}^{nel} \eta_I (K_{IK}^e \varphi_K - F_I^e) = 0. \quad (28)$$

Here, \mathbf{A} denotes the assembly operator with $numel$ the total number of elements to discretize the problem. The contribution of nodes I and K to the stiffness matrix and of node I to the load vector reads

$$K_{IK}^e = \int_{(\Omega_e)} (N_{I,y} N_{K,y} + N_{I,z} N_{K,z}) dA_e \quad F_I^e = \int_{(\Omega_e)} (f_0 N_I + f_1 N_{I,y} + f_2 N_{I,z}) dA_e, \quad (29)$$

where the functions $f_0(y, z)$, $f_1(z)$ and $f_2(y)$ are given in (6) and (4), respectively. The section quantities A , $A_{\bar{y}\bar{y}}$, $A_{\bar{z}\bar{z}}$, $A_{\bar{y}\bar{z}}$, y_S , z_S , y_0 and z_0 must be known. This can be achieved using a finite element solution, see [13]. Eq. (28) leads to a linear system of equation. To solve the system the value φ_I of one arbitrary nodal point I has to be suppressed.

The present weak form (17) does not show any boundary integral. Thus, the associated element formulation (29) is easy to implement into a finite element program and reduces the amount of input data in comparison to the previous formulation in [8].

5 Examples

The presented finite element formulation has been implemented into an enhanced version of the program FEAP. A documentation of the basis version may be found in the book of Zienkiewicz und Taylor [14]. At re-entrant corners the shear stresses are unbounded. The below presented plots show the distribution for a chosen mesh density. Further mesh refinement influences the results only in the direct vicinity of the singularity. The evaluated shear correction factors represent converged solutions.

5.1 Rectangular cross-section

The first example is concerned with a rectangular cross-section, see Fig. 2. In the following the distribution of the shear stresses due to a shear force $Q_z = 1$ is investigated. Within the elementary beam theory the shear stresses τ_{xz} are given according to the quadratic parabola $\tau_{xz} = \tau^*[1 - (2z/h)^2]$ with $\tau^* = 1.5 Q_z/A$.

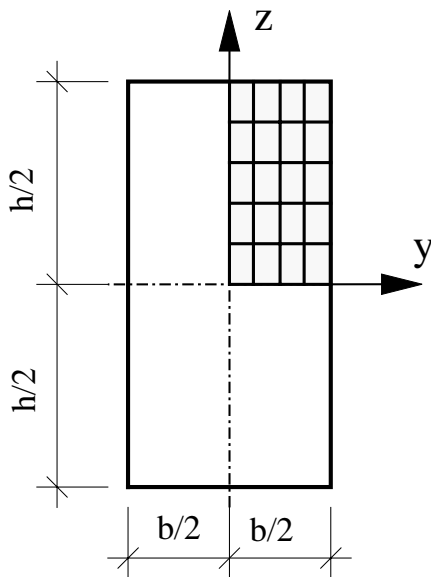

Table 1: Factors for the shear stresses of a rectangular cross-section ($\nu = 0.25$)

h/b	2	1	0.5	0.25
$z=0, y=0$	0.983	0.940	0.856	0.805
$z=0, y=b/2$	1.033	1.126	1.396	1.988

Fig. 2: Rectangular cross-section

Considering symmetry one quarter is discretized by $n \times n$ 4-noded elements. With Poisson's ratio $\nu = 0$ we obtain the finite element solution $\tau_{xy} = 0$ and τ_{xz} according to the elementary theory, thus constant in y and quadratic in z . For $\nu \neq 0$ a theoretical solution has been evaluated by Timoshenko and Goodier [4] using Fourier series. The finite element results of two points for $\nu = 0.25$ and different ratios of h/b correspond with the series solution published in [4], see table 1. The above defined maximum shear stress τ^* of the elementary beam theory has to be multiplied with the factors of the table to obtain the correct stresses at the specified points. For a square cross-section the error in the maximum stress of the elementary beam theory is about 13 %. Plots of the normalized shear stresses τ_{xz}/τ^* for a square are given in Fig. 3. Fig. 4 shows that the shape of τ_{xz}

for $\nu = 0$ is identical with the quadratic parabola of the elementary theory. Furthermore the distribution along $z = 0$ and $\nu = 0.25$ is given in Fig. 5. The stress concentration at $z = 0, y = \pm b/2$ can be seen clearly.

Finally shear correction factors according to eq. (26) are computed, see table 2. As can be seen the well-known quantity $\kappa_z = 5/6$ has been verified for $\nu = 0$. However, for a decreasing ratio h/b and increasing ν much lower values for κ_z are evaluated. This result is obvious since the shear stress distribution deviates considerable from the elementary beam theory, see table 1. The factors of Cowper [9] are independent of the aspect ratio. In our approach this holds only for $\nu = 0$.

Table 2: Shear correction factors κ_z for a rectangular cross-section

h/b	2	1	0.5	0.25
$\nu = 0$	0.8333	0.8333	0.8333	0.8333
$\nu = 0.25$	0.8331	0.8295	0.7961	0.6308
$\nu = 0.5$	0.8325	0.8228	0.7375	0.4404

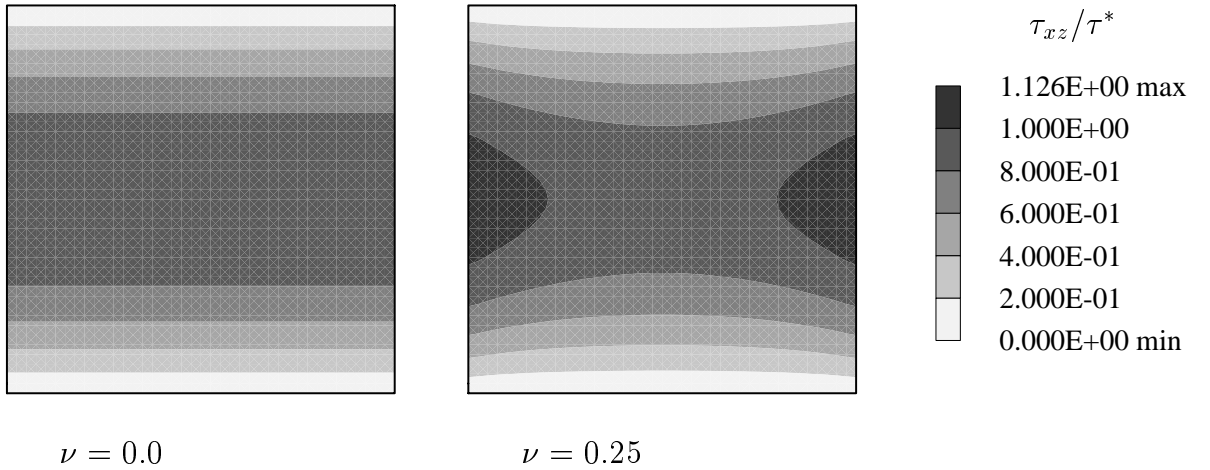

Fig. 3: Normalized shear stresses for a square cross-section

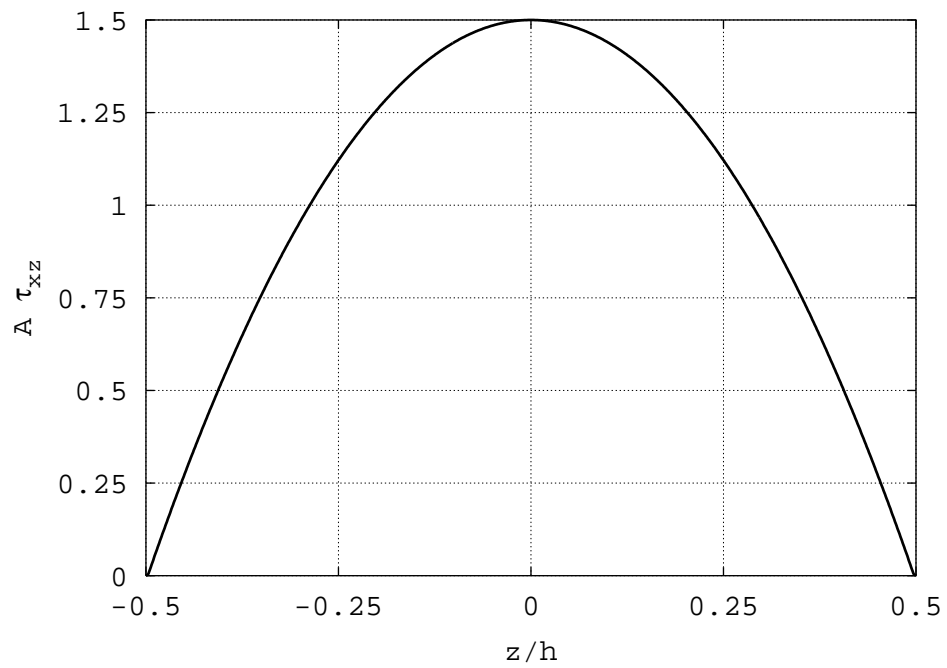

Fig. 4: Normalized shear stresses for a square with $y = \text{constant}$ and $\nu = 0$

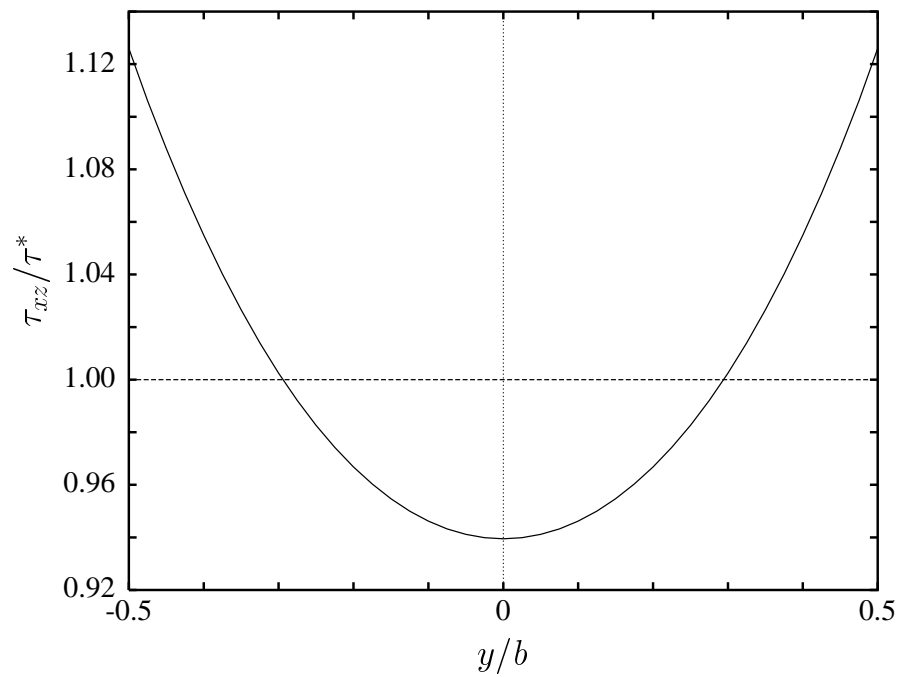

Fig. 5: Normalized shear stresses at $z = 0$ for a square with $\nu = 0.25$

5.2 Cross-section with varying width

The next example is concerned with a cross-section with varying width, see Fig. 6. The geometrical data are $a = 10 \text{ cm}$, $z_S = 1.6667 a$, $z_M = 1.4457 a$ and $z_0 = 1.5871 a$. Considering symmetry one half of the cross-section is discretized with four-node elements. Fig. 7 shows a plot of the shear stresses τ_{xz} for $\nu = 0$ and $\nu = 0.2$ due to $Q_z = -1 \text{ kN}$. The distribution in y -direction deviates considerably from a constant shape. Applying further mesh refinement one recognizes a singularity at the re-entrant corner. A plot of the resulting shear stresses is depicted in Fig. 8. The shear correction factors are computed for different ratios ν and are summarized in table 3. In this case Poisson's ratio does not influence the results in a significant way.

Table 3: Shear correction factors for a cross-section with varying width

ν	0	0.25	0.5
κ_y	0.7395	0.7355	0.7294
κ_z	0.6767	0.6753	0.6727

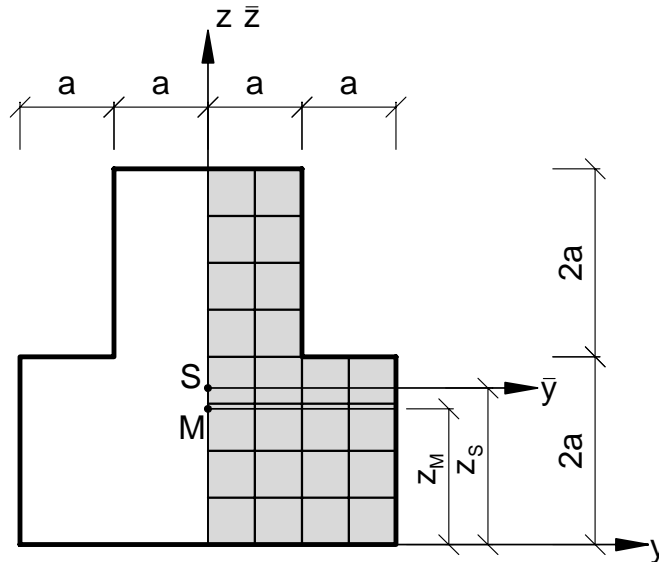

Fig. 6: Cross-section with varying width

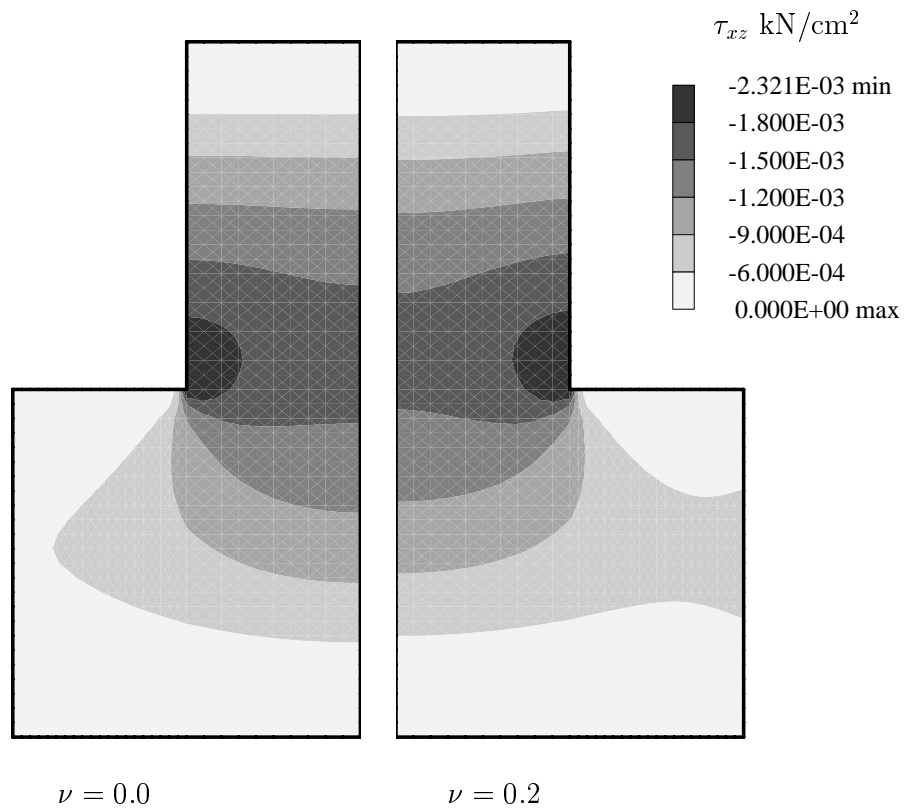

Fig. 7: Plot of shear stresses τ_{xz}

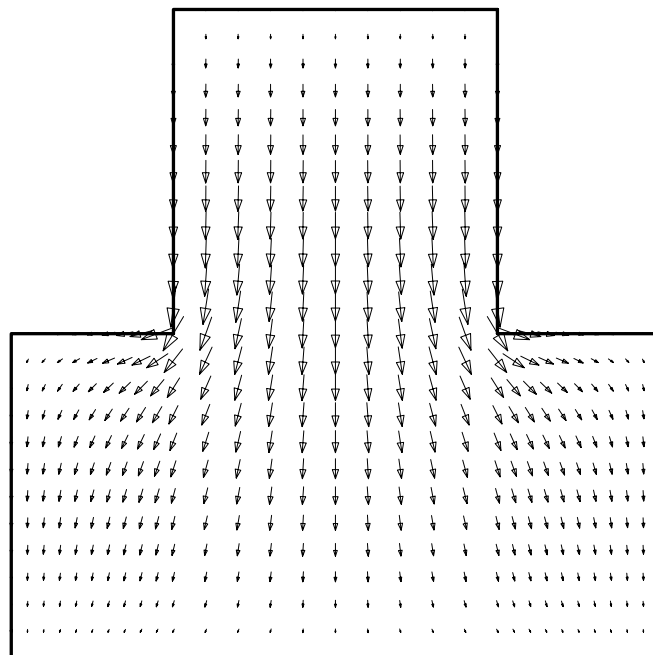

Fig. 8: Resulting shear stresses for $\nu = 0.2$

5.3 Crane rail A 100

The cross-section of a crane rail A100 according to the German code DIN 536 is investigated next, see Fig. 9. We consider shear forces $Q_y = 1 \text{ kN}$ and $Q_z = -1 \text{ kN}$. One half of the cross-section is discretized using four-node-elements, see Fig. 10. The constant is determined as $z_0 = 5.078 \text{ cm}$. As Fig. 11 shows there are considerable stress concentrations in the cross-section. Only minor differences occur for the two ratios $\nu = 0$ and $\nu = 0.3$. The resulting shear stresses are plotted for $\nu = 0.3$ in Fig. 12 and Fig. 13. Finally, the shear correction factors are summarized in table 4. There are only minor differences for $\nu = 0$ and $\nu = 0.3$.

Table 4: Shear correction factors of a crane rail A 100

ν	0	0.3
K_{y}	0.6845	0.6836
K_{z}	0.4474	0.4468

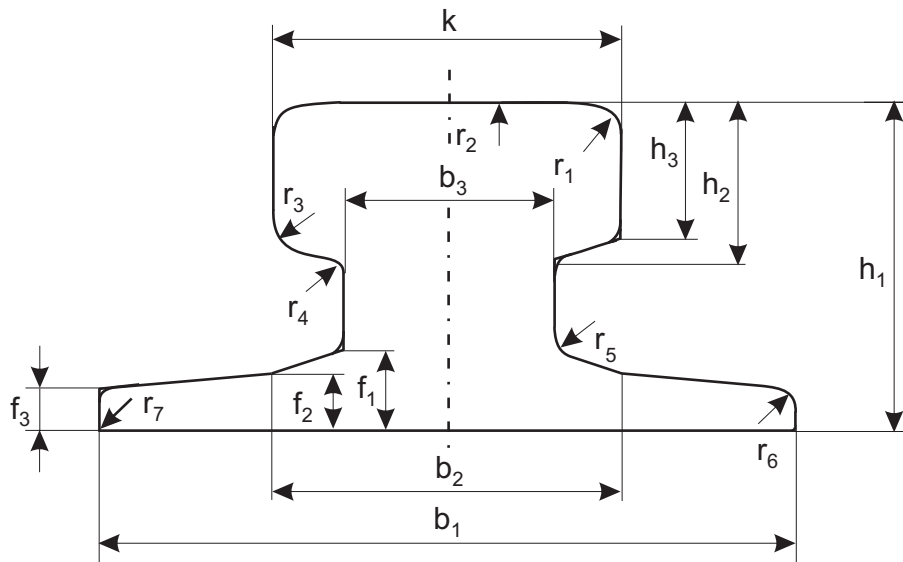

k	r ₁	r ₂	r ₃	r ₄	r ₅	r ₆	r ₇	
100	10	500	6	6	8	6	1,5	
b ₁	b ₂	b ₃	h ₁	h ₂	h ₃	f ₁	f ₂	f ₃
200	100	60	95	45,5	40	23	16,5	12

Fig. 9: Geometry of a crane rail A 100 in *mm*

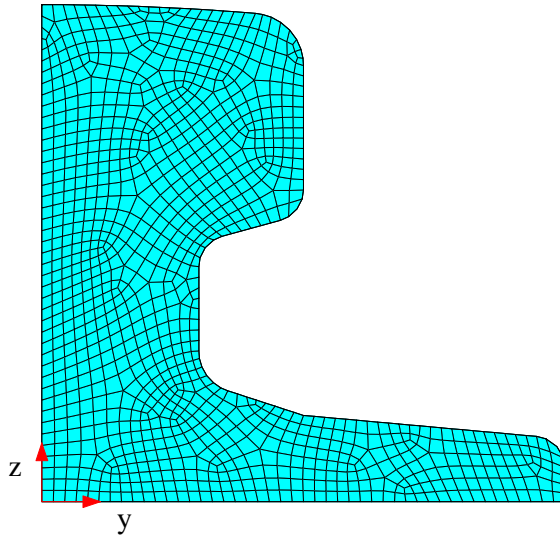

Fig. 10: Discretization of a crane rail

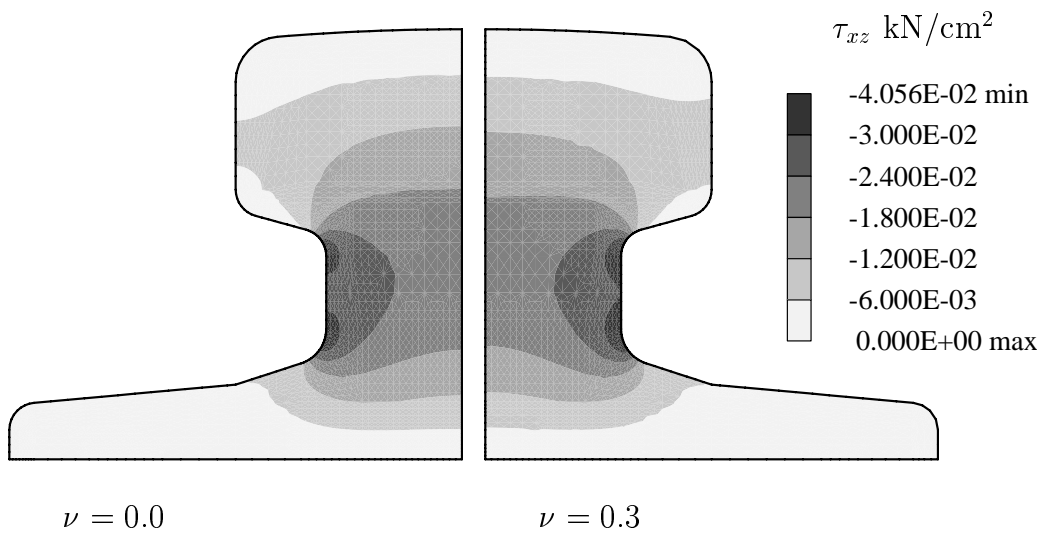

Fig. 11: Shear stresses of a crane rail for $Q_z = -1 \text{ kN}$

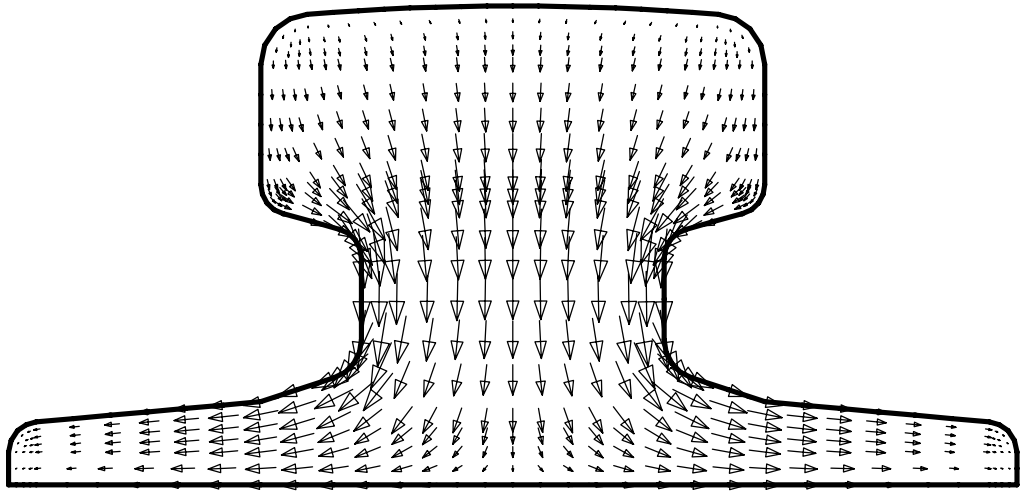

Fig. 12: Resulting shear stresses of a crane rail for $Q_z = -1 \text{ kN}$

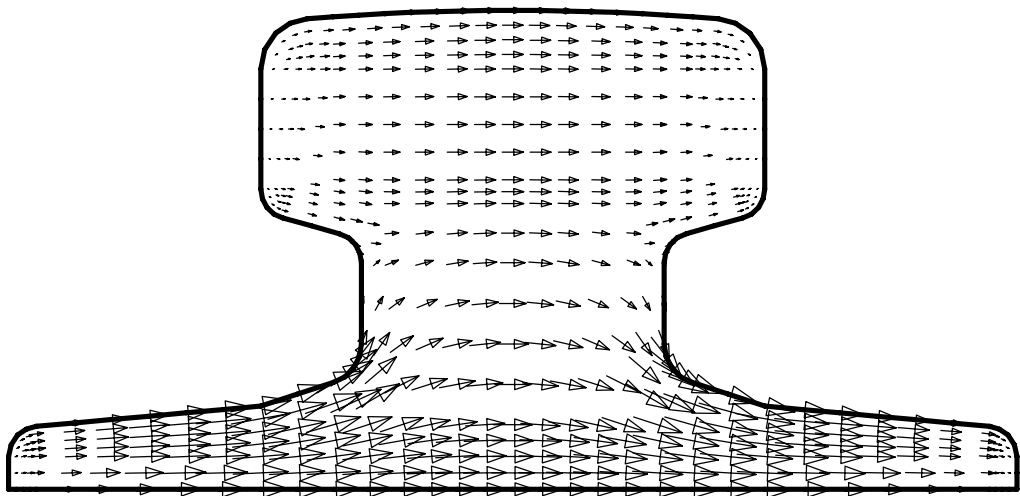

Fig. 13: Resulting shear stresses of a crane rail for $Q_y = 1 \text{ kN}$

5.4 Bridge cross-section

The bridge cross-section according to Fig. 14 is an example for a multiple connected domain, see [7]. The constant z_0 is evaluated as $z_0 = 1.775\text{ m}$. Considering symmetry the computation is performed at one half of the cross-section, see Fig. 15. The resulting shear stresses are depicted for shear forces Q_y and Q_z in Fig. 16 and Fig. 17, respectively. One can see the qualitative split of the flux at the branches. Table 5 shows that within this example ν practically does not influence the shear correction factors.

Table 5: Shear correction factors of a bridge cross-section

ν	0	0.2
K_{y_1}	0.5993	0.5993
K_{z_1}	0.2312	0.2311

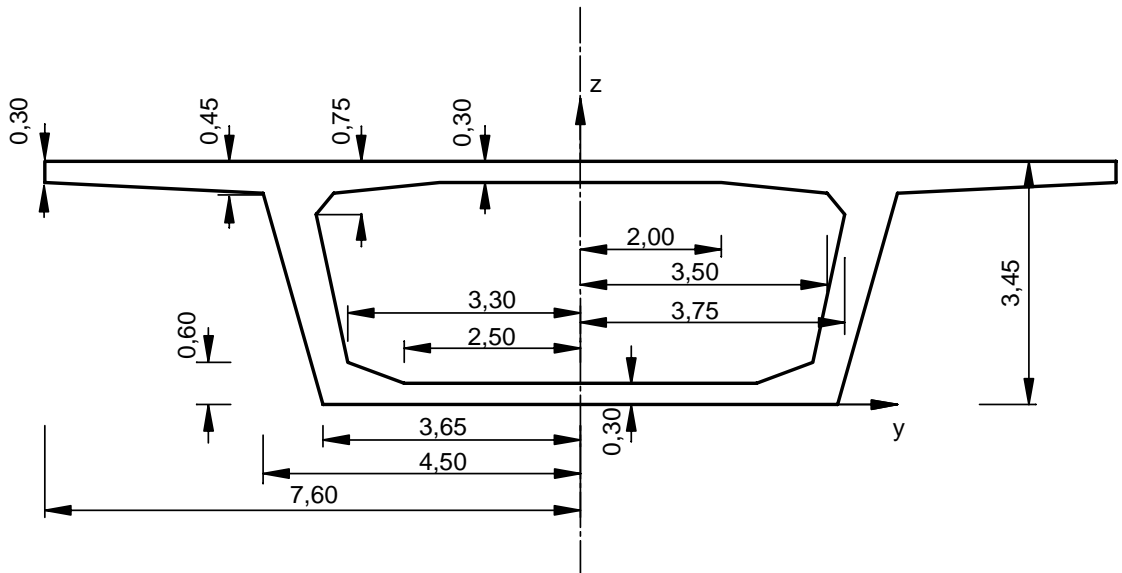

Fig. 14: Bridge cross-section, with measurements in m

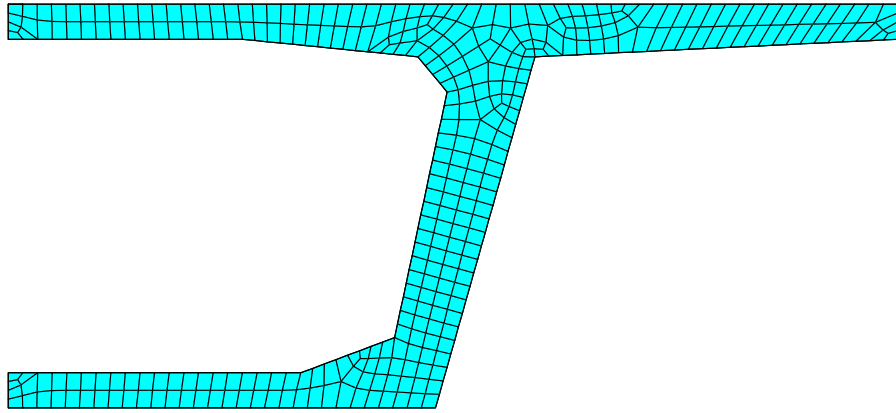

Fig. 15: Discretization of the bridge cross-section

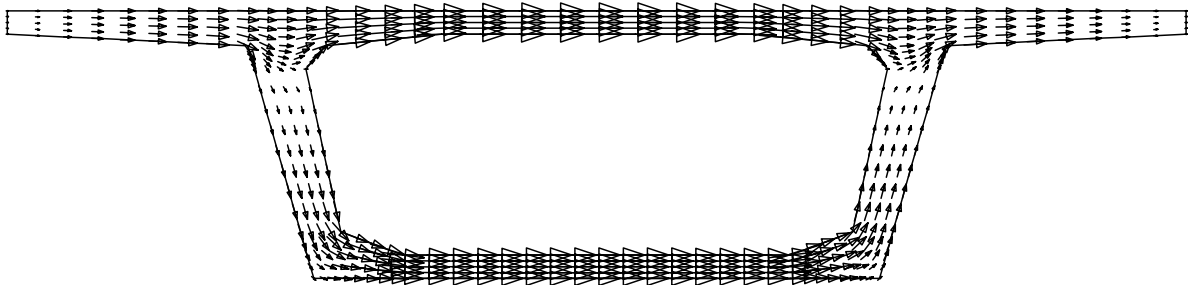

Fig. 16: Resulting shear stresses of the bridge cross-section for $Q_y = 1 \text{ kN}$

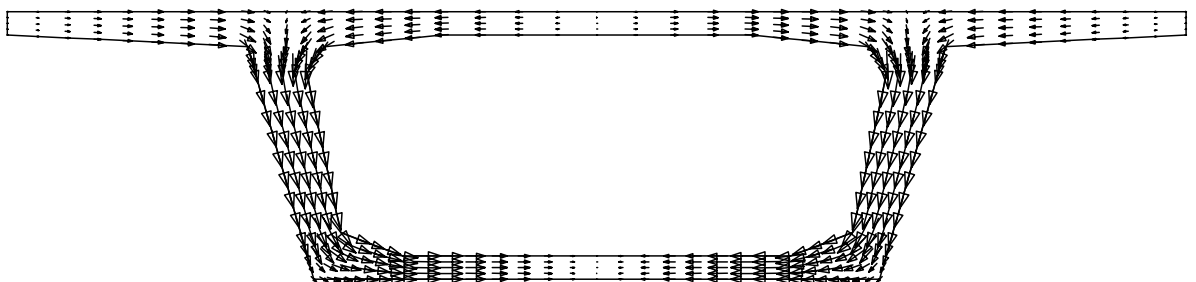

Fig. 17: Resulting shear stresses of the bridge cross-section for $Q_z = -1 \text{ kN}$

6 Conclusions

Assuming linear elastic behaviour and using assumptions for the stress field the shear stresses in prismatic beams subjected to torsionless bending are derived. One obtains a simple weak form of the boundary value problem in terms of the warping function with homogeneous stress boundary conditions. The associated element formulation can easily be implemented into a standard finite element program. Based on the stored strain energy of the shear stresses correction factors for arbitrary shaped beam sections are introduced which consider the different stress distributions. Various examples show the efficiency of the derived formulation. Poisson's ratio has essential effect on wide cross-sections. In contrast to that the results for thin-walled sections are practically insensitive against transverse contraction.

A Appendix: Constants for torsionless bending

There are different definitions of torsionless bending in the literature, see Timoshenko and Goodier [4]. Here, we follow the approach of Weber [1] and Trefftz [3]. Hence, the application of the Betty–Maxwell reciprocal relations leads to the fact that the coordinates of the center of shear and of the center of twist are identical, the latter being defined as the point of rest in every cross-section of a twisted beam. As a result of this approach y_M and z_M are independent of Poisson's ratio ν . A different definition of bending without torsion was given by Goodier [15].

Introducing the torsion function Φ of the Saint–Venant torsion theory by

$$-\Phi_{,y} = \bar{\omega}_{,z} + y \quad \Phi_{,z} = \bar{\omega}_{,y} - z \quad (30)$$

where $\bar{\omega}$ denotes the unit warping function and inserting this into the condition

$$Q_z y_M - Q_y z_M = \int_{(\Omega)} (\tau_{xz} y - \tau_{xy} z) dA \quad (31)$$

we obtain

$$Q_z y_M - Q_y z_M = - \int_{(\Omega)} (\tau_{xy} \bar{\omega}_{,y} + \tau_{xz} \bar{\omega}_{,z}) dA + \int_{(\Omega)} (\tau_{xy} \Phi_{,z} - \tau_{xz} \Phi_{,y}) dA. \quad (32)$$

Applying integration by parts to the first integral yields

$$- \int_{(\Omega)} (\tau_{xz} \bar{\omega}_{,z} - \tau_{xz} \bar{\omega}_{,y}) dA = \int_{(\Omega)} (\tau_{xy,y} + \tau_{xz,z}) \bar{\omega} dA - \oint_{(\partial\Omega)} (\tau_{xy} n_y + \tau_{xz} n_z) \bar{\omega} ds. \quad (33)$$

The boundary integral vanishes considering (14)₂. Inserting (14)₁ and (6) one obtains

$$- \int_{(\Omega)} (\tau_{xz} \bar{\omega}_{,z} - \tau_{xz} \bar{\omega}_{,y}) dA = - \int_{(\Omega)} f_0 \bar{\omega} dA = -a'_y A_{\bar{\omega}\bar{y}} - a'_z A_{\bar{\omega}\bar{z}}. \quad (34)$$

Introducing the coordinates of the center of shear which are identical with the coordinates of the center of twist, see e.g. [13]

$$y_M = - \frac{A_{\bar{\omega}\bar{z}} A_{\bar{y}\bar{y}} - A_{\bar{\omega}\bar{y}} A_{\bar{y}\bar{z}}}{A_{\bar{y}\bar{y}} A_{\bar{z}\bar{z}} - A_{\bar{y}\bar{z}}^2} \quad z_M = \frac{A_{\bar{\omega}\bar{y}} A_{\bar{z}\bar{z}} - A_{\bar{\omega}\bar{z}} A_{\bar{y}\bar{z}}}{A_{\bar{y}\bar{y}} A_{\bar{z}\bar{z}} - A_{\bar{y}\bar{z}}^2} \quad (35)$$

and combining (32) and (34) we obtain

$$0 = \int_{(\Omega)} (\tau_{xy} \Phi_{,z} - \tau_{xz} \Phi_{,y}) dA = \int_{(\Omega)} [(\varphi_{,y} - f_1) \Phi_{,z} - (\varphi_{,z} - f_2) \Phi_{,y}] dA. \quad (36)$$

Integration by parts yields

$$\int_{(\Omega)} (\Phi_{,z} f_1 - \Phi_{,y} f_2) dA - \int_{(\Omega)} (\Phi_{,zy} - \Phi_{,yz}) \varphi dA + \oint_{(\partial\Omega)} (\Phi_{,y} n_z - \Phi_{,z} n_y) \varphi ds = 0 \quad (37)$$

The second integral is obviously zero. The same holds for the boundary integral, since $d\Phi = (\Phi_{,y} n_z - \Phi_{,z} n_y) ds = 0$ on $\partial\Omega$. Thus using (4), we obtain

$$\int_{(\Omega)} (\Phi_{,z} f_1 - \Phi_{,y} f_2) dA = \frac{\nu}{2(1+\nu)} \int_{(\Omega)} [\Phi_{,z} a'_y (z - z_0)^2 - \Phi_{,y} a'_z (y - y_0)^2] dA = 0. \quad (38)$$

Next, the following definitions are introduced

$$\begin{aligned} B_y &:= \int_{(\Omega)} (-\Phi_{,y}) y dA &= \int_{(\Omega)} (\bar{\omega}_{,z} + y) y dA \\ B_{yy} &:= \int_{(\Omega)} (-\Phi_{,y}) y^2 dA &= \int_{(\Omega)} (\bar{\omega}_{,z} + y) y^2 dA \\ B_z &:= \int_{(\Omega)} \Phi_{,z} z dA &= \int_{(\Omega)} (\bar{\omega}_{,y} - z) z dA \\ B_{zz} &:= \int_{(\Omega)} \Phi_{,z} z^2 dA &= \int_{(\Omega)} (\bar{\omega}_{,y} - z) z^2 dA. \end{aligned} \quad (39)$$

The resultants of the torsion shear stresses vanish, Sokolnikoff [5]

$$\int_{(\Omega)} \Phi_{,z} dA = 0 \quad \int_{(\Omega)} \Phi_{,y} dA = 0. \quad (40)$$

Inserting (39) and (40) into eq. (38) yields

$$\frac{\nu}{2(1+\nu)} [a'_y (B_{zz} - 2z_0 B_z) + a'_z (B_{yy} - 2y_0 B_y)] = 0. \quad (41)$$

The constants a'_y and a'_z according to (11) are not zero. Therefore eq. (41) can only be fulfilled if the terms in both brackets vanish which yields

$$y_0 = \frac{B_{yy}}{2B_y} \quad z_0 = \frac{B_{zz}}{2B_z}. \quad (42)$$

If z is symmetry axis $y_0 = 0$ holds and vice versa.

References

- [1] Weber, C. (1924): Biegung und Schub in geraden Balken. ZAMM. vol. 4, pp. 334–348 [1](#), [A](#)
- [2] Schwalbe, W. L. (1935): Über den Schubmittelpunkt in einem durch eine Einzellast gebogenen Balken. ZAMM. vol. 15, pp. 138–143 [1](#)
- [3] Trefftz, E. (1935): Über den Schubmittelpunkt in einem durch eine Einzellast gebogenen Balken. ZAMM. vol. 15, pp. 220–225 [1](#), [A](#)
- [4] Timoshenko S. P., Goodier J. N. (1970): Theory of Elasticity, 3rd edn, McGraw–Hill International Book Company [1](#), [5.1](#), [A](#)
- [5] Sokolnikoff I. S. (1956): Mathematical Theory of Elasticity, McGraw–Hill, New York [1](#), [A](#)
- [6] Mason W. E., Herrmann L. R. (1968): Elastic shear analysis of general prismatic beams. J. Eng. Mech. Div. ASCE, vol. 94, EM4, pp. 965–983 [1](#), [3](#)
- [7] Zeller C. (1985): Zur Bestimmung der Verwölbungen und Profilverformungen von elastischen Stäben mit beliebigen und dünnwandigen Querschnitten. Ingenieur–Archiv vol. 55, pp. 376–387 [1](#), [5.4](#)
- [8] Gruttmann F., Sauer R. , Wagner W. (1999): Shear stresses in prismatic beams with arbitrary cross–sections. Int. J. Num. Meth. Engng., vol. 45, pp. 865–889 [1](#), [4](#)
- [9] Cowper, G. R. (1966): The shear coefficient in Timoshenko’s beam theory. J. Appl. Mech. vol. 33, No 2, pp. 335–340 [3](#), [5.1](#)
- [10] Timoshenko, S. P. (1940): Strength of Materials, 2nd edn, D. Van Nostrand Company, Inc., New York [3](#)
- [11] Stojek, D. (1964): Zur Schubverformung im Biegebalken. ZAMM. vol. 44, pp. 393–396 [3](#)
- [12] Bach C., Baumann R. (1924): Elastizität und Festigkeit, 9th edn, Springer, Berlin [3](#)
- [13] Gruttmann F., Wagner W., Sauer R. (1998): Zur Berechnung von Wölbfunktion und Torsionskennwerten beliebiger Stabquerschnitte mit der Methode der finiten Elemente. Bauingenieur. vol. 73 (3), pp. 138–143 [4](#), [A](#)
- [14] Zienkiewicz O.C., Taylor R.L. (1989): The Finite Element Method, 4th edn, McGraw–Hill, London [5](#)
- [15] Goodier, J. N. (1944): A theorem on the shearing stress in beams with applications to multicellular sections. J. Aeronautical Sciences, vol. 11, pp. 272–280 [A](#)