

48th CIRP Conference on MANUFACTURING SYSTEMS - CIRP CMS 2015

Planning support for the design of quality control strategies in global production networks

Tobias Arndt^{a,*}, Gisela Lanza^a

^aKarlsruhe Institute of Technology (KIT), wbk Institute of Production Science, Kaiserstr. 12, 76131 Karlsruhe, Germany

* Corresponding author. Tel.: +49-721-608-44297; fax: +49-721-608-45005. E-mail address: tobias.arndt@kit.edu

Abstract

The increasing globalization forces manufacturing companies to organize their production in global networks, which include company internal sites as well as locations of external partners and suppliers. Each site in this network has an assigned strategic role according to the specific location factors, i.e. qualification level of employees or available process technology, and the defined specialization of each site, i.e. regarding served market, final product or realized processes. This role defines an individual target system that considers at least the dimensions cost, quality and time. Each site acts autonomously according to the target system. Since it is crucial for the success of the company to ensure the demanded quality of the final product with minimal cumulated quality costs and lead times, the quality control strategy for the production network has to be designed according to the target systems of the individual sites. The presented article describes an approach, which enables globally operating companies to efficiently plan their efforts for their quality control measures in their respective production network taking the specific site roles into account. In a first step, a value-stream-based methodology is presented, which visualizes quality characteristics as well as related quality inspections in the production process chain and which identifies potentials in the quality control strategy across locations. In a second step a simulation approach is used to evaluate the effects of different quality measures considering dynamic influencing factors and individual target systems, so that the optimal quality control strategy for the production network can be identified.

© 2015 The Authors. Published by Elsevier B.V. This is an open access article under the CC BY-NC-ND license (<http://creativecommons.org/licenses/by-nc-nd/4.0/>).

Peer-review under responsibility of the scientific committee of 48th CIRP Conference on MANUFACTURING SYSTEMS - CIRP CMS 2015

Keywords: Global production networks; Strategic site role; Quality control strategy; Simulation-based evaluation

1. Introduction

Manufacturing in global production networks is becoming increasingly important against the background of growing global competition and rapid globalization of sales and procurement markets [1]. These networks can be characterized by a wide range of services and supplies between corporate sites and locations of external partners and suppliers. Players involved in the value-adding process increasingly focus on their core competencies and specialize in regard to manufactured products, the supplying market or the processes carried out [2].

At the same time, the individual sites in the production network are often assigned a strategic importance or role of the location (e.g. lead factory, low-cost production) depending on the specialization and the respective site factors (e.g. qualification level of employees, process technology, delivery

quality). Along with this, a space of action or target system is defined in which the sites act autonomously and define individual optimization measures depending on their respective target system. This results in mutual interdependence, goal conflicts and asymmetric information distribution among the participating sites [3].

Overall, the challenge for companies is to control the strategically designed network, the efficiency and effectiveness of which determine the ultimate success of the company, in their own interest under the described conditions at operational level [4]. Especially the assurance of exceptional product quality implicates special challenges in this context [5]. Despite long supply chains with many partners involved and divergent location factors, the required quality of the final product must be ensured with minimum cumulative quality and testing costs, as such activities are not perceived as value-adding by customers and are thus not paid.

Therefore, this article presents an approach which enables globally operating companies to purposefully and efficiently plan their efforts for their quality control measures in their respective production network taking the specific site roles into account. In chapter 2 existing challenges in the field of quality control strategies in global production networks are stated. Hereafter the current state of the art in literature regarding this topic is presented in chapter 3. The developed method is elaborated on in chapter 4. Finally, chapter 5 concludes with a summary.

2. Challenges of quality control in global production networks

In this article quality control strategies are defined as consisting of an inspection strategy (including inspection characteristic, device and location etc.) and the implementation of quality measures (including poka-yoke measure, process improvement, supplier qualification etc.). Currently these strategies completely focus on the considered process, without adequately regarding the specific site roles and taking the impact (cost / benefit) on the production network into account, although there are quality-related influencing factors on all three levels, as Figure 1 shows.

That results in the fact that quality measures may not be carried out after intra-site cost / benefit analysis even though they had a positive effect in a holistic view of the production network. Also, cross-site optimization potentials in the inspection planning (e.g. higher utilization of expensive measuring equipment at other sites) cannot be realized, or redundant tests at different locations may be carried out, which can lead to significant inefficiencies in the production network. Lack of transparency in the overall process also leads to long time intervals between cause of failure in the production process and identification of the failure. This causes a potential quality defect to be recognized too late. This means that there is value added to defective intermediate products and an increasing transport of scrap, which results again in higher costs and long replacement times. There is also the risk that through the increasing reduction of stocks in the production process, quality defects lead to significant disturbances, for example production shutdowns in the downstream value chain, and this way possibly propagate towards the final customer [6].

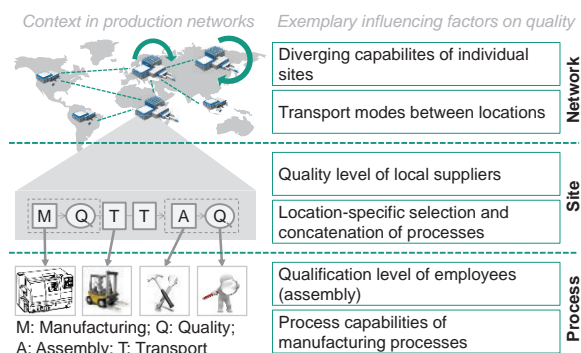

Fig. 1. Influencing factors on quality control strategies

For this reason, the main challenges for companies are on the one hand to predict the concatenation and propagation of quality defects as well as the resulting impact on the specific production network [7]. On the other hand, a visualization of improvement potentials in the multi-site quality control strategy has so far been limited, because linked and interdependent multi-site value-adding processes lead to multiplier effects and mutual dependencies. These have to be regarded while identifying cross-site potentials in the respective quality control strategy. Furthermore, the question, with which measures companies should respond to the identified potentials in their quality control strategy cannot be answered clearly, because their impact on the overall network cannot be evaluated, especially not prior to its potentially costly implementation.

3. State of the art

3.1. Coordination and configuration of global production networks

According to Sydow, production networks constitute a hybrid form of cooperation between the poles of market and hierarchy, whose central features are relatively stable cooperative relations between legally independent but economically interconnected companies. The participating actors influence the overall performance of the network by their individual behaviour, which is based on their objectives [8]. To account for this challenge, Richert presents an approach for extending the Balanced Scorecard methodology to production networks [9]. The approach is intended to coordinate the divergent goals and interests of the actors in the production network by allowing the actors to communicate directly with each other to jointly derive an optimal target system for the entire network [9]. A derivation of target system typologies to provide recommendations for different site roles location is not realized.

On the other hand, there are research approaches which explicitly focus on the design, evaluation and optimization of production networks. Design approaches often describe holistic procedures for the planning of production networks, such as the approach by Herm: He distributes the production based on globally distributed business capabilities, which represent the competences of a potential network instance for the provision of a service [10]. Evaluation approaches, such as that of Kampker et al., provide new assessment procedures for the configuration of production networks. In their approach, measures for a complexity-oriented design of production networks are derived, describing the change from a stable state of a production network to a turbulent system state. Thus, a basic understanding of the fundamental mechanisms of instabilities in the production network in terms of quality, cost and schedule are developed [11]. In the field of optimization of production networks, Kohler gives a clear summary of existing approaches [12]. All the described approaches have in common that they evaluate different target systems of the stakeholders and resulting interactions only rudimentary, if at all. The topic of quality control in the production network is often only regarded marginally.

3.2. *Quality control in production networks*

Quality control in production networks is a relatively young research field. Initial works that address its definition come e.g. from Forster [13] or Kaynak and Hartley [14]. Fish shows the positive influences between quality management and coordination of production networks and identifies measures from product development to service [15]. As significant positive influences he quotes improved cycle time, flexibility and timeliness of delivery by reducing process variation, stocks and unnecessary transport (transport of defective parts) by lower scrap rates [15].

Batson and McGough demonstrate in their analysis the possible effects on quality control at the concatenation of production processes of a multi-component product. They present two simple quality models based on discrete and continuous observation. They see further research demand regarding the development of models for measurement, evaluation and optimization of quality in production networks in addition to organizational approaches for its control [16].

Erasmus highlights the importance of information exchange in global production networks in an empirical study. Because of the challenge to transfer this information between companies and at the same time to ensure its usability under linguistic and cultural influences, he postulates a specific definition of interfaces that enable an unambiguous clarity of the information [17]. His approach focusses on interface problems without considering case-specific configurations of the production network.

Das and Sengupta set up a mathematical network model consisting of multiple suppliers, a central enterprise and several retailers. The formulated central question is how to configure the network in order to serve the market at optimal cost, while taking the capabilities of suppliers, e.g. quality rates, process skills and the quality management system into account [18]. The approach illustrates that in production networks cross-site coordination and configuration involving various competencies can lead to an optimum. However, the practical applicability of the model cannot be shown.

3.3. *Simulation of production networks*

A suitable approach to model a production network with the illustrated characteristics is the so-called agent-based simulation [19]. In agent-based models independent agents act on the basis of predefined rules both with each other and with their environment. One of the typical characteristics of agent-based simulation is decentralized data storage. This means that each agent has incomplete information and thus is equipped with limited problem-solving skills, with which it pursues its own goals. All calculations are performed locally and asynchronously, so that multi-agent systems have no central evaluative control instance. Therefore, agent-based simulation is particularly suitable for systems, which consist of autonomous entities, and is hence already been widely used for the operational planning of production networks [20].

Giannakis presents a framework based on agent-based simulation, whose objective is the recognition and avoidance of supply risks in production networks. For this purpose

information of the supplier such as its production progress is combined in Key Performance Indicators and compared with reference values to detect deviations from expected values. In case of deviations the consequences are calculated by means of an integrated simulation environment and suitable action proposals are determined [21]. It is not further specified, which specific measures can be used to prevent the risks.

The framework for an agent-based simulation developed by Long et al. aims at the simulation of processes in complex supply chains and allows for describing individual resources or transport units and its capacities. Therefore, capacity planning in the production network could be an application [22]. Since target systems of the individual units as well as control or decision options are not regarded, the advantage of agent-based simulation remains partially unused.

Overall, the presented approaches show, that agent-based simulation is well suited to depict the characteristics of real production networks. However, there are currently no approaches that use agent-based simulation combined with a discrete-event simulation to evaluate quality control strategies in terms of benefits for the entire production network.

4. *Methodology*

The presented three-step approach addresses these issues. In the first step the status quo of the company-specific quality control strategy is analysed and a method for the visualization of improvement potentials is developed. Based on this, in the second step a network simulation as a combination of discrete-event and multi-agent simulation is developed, in order to model individual network structures consisting of different sites with specific site roles. Afterwards, the network simulation is extended by an assessment module. Thus, an optimal cross-site inspection strategy can be identified and a cost/benefit analysis of different discrete combinations of quality measures can be conducted.

4.1. *Analysis*

In the first step of the analysis phase, all relevant production and transportation processes and their respective performance indicators are recorded. According to the multi-site value stream analysis, these include cycle times, setup times, availabilities and inventory for production processes as well as time, distance and frequency for transportation processes [23]. Additionally, all quality-related processes such as quality inspections, rework and scrapping processes are integrated in the analysis using the notation according to Haefner et al. [24]. In a second step, relevant quality performance indicators are calculated and visualized in an information box below the respective quality process. For quality inspections these include: test duration, inspection characteristics, identified failures and the process capability index. For rework processes their respective costs and required times are recorded as well as scrapping costs and the value of the scrapped part for scrapping processes. Supported by methods like the Ishikawa analysis [25], failure causes are identified and noted in the information boxes below the corresponding production processes as shown in Figure 2.

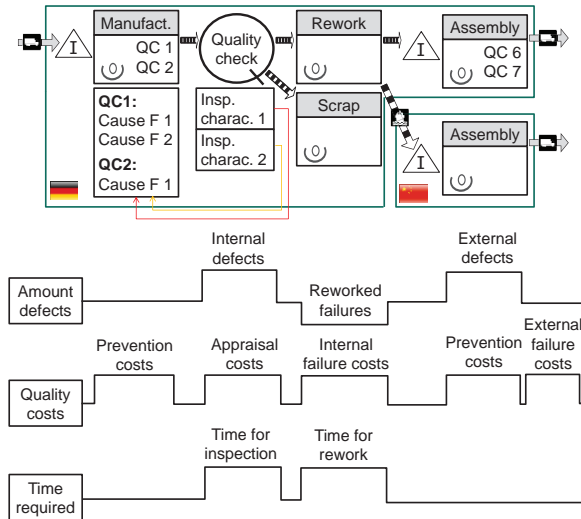

Fig. 2. Visualisation of potentials in the quality control strategy

Subsequently, based on this analysis, quality control loops are drawn into the diagram, linking the existing quality processes with their respective inspection characteristics to the causes of failure. Each quality control loop is then characterized by an extended risk priority number (RPN_{ext}). According to the Failure Mode and Effects Analysis (FMEA), the original RPN depends on the severity of the failure (S), and the probability of the occurrence of the failure (O) and the probability of detecting the failure (D). In addition, the RPN_{ext} contains indicators for the increased value of the product until the discovery of the failure (V) and the replacement time (R). According to McDermott et al., all indicators are rated from 1 to 10 [26].

The severity depends on the consequences for the customer, if the failure is not identified before delivery. The value of the indicator can be derived from interviews with the customer. For the value of the occurrence probability, the capability index of the production process can be taken as a reference. The lower the process capability index, the higher is the occurrence probability. The probability of detecting the failure is determined by the quality of the inspection process. Therefore, the inspection process capability can be taken as a reference for the value of the detection probability. The indicator for the increased value describes the amount of value added to a potentially defective product. It can be derived from the difference between the sum of production and transportation costs until the production process and the respective inspection process. The replacement time describes the time needed for replacing a defective product by a flawless one. It can be derived from the sum of production, quality process, storage and transportation time between the production and the related quality inspection process. Potentials in the quality control strategy can be visualised by colouring the quality control loop in accordance to the value of the extended RPN by green, yellow or red arrows (Fig. 2).

In addition, the overall status of the value stream is evaluated with respect to the amount of defects, the quality-related costs and the quality-related time. The evaluation is

visualized by means of a defect curve, a quality cost curve and a time curve (Fig. 2). For the depiction of the defect curve, the number of defects of all inspection characteristics is determined for each inspection process (internal defects). Moreover, the number of reworked failures is calculated for each of the rework processes as well as the number of failures identified by each customer (external defects). To determine the quality cost curve, for each process all relevant types of quality-related costs are calculated, which are classified into prevention costs, appraisal costs, internal failure costs (rework and scrapping costs) and external failure costs e.g. induced by customer reclamation. For the time curve for all quality-related processes inspection times and rework times are calculated. That way, all necessary indicators for evaluating the quality control strategy are gathered, potentials are visualised as well as interfaces regarding communication and transportation to the other actors in the respective production network are depicted.

4.2. Network simulation

in the next step, a network simulation is developed in order to evaluate the advantageousness of different inspection strategies and quality control measures for each site or the entire production network taking into account the network-specific characteristics and dynamic influencing factors. This is shown schematically in Figure 3. The simulation is created using the software AnyLogic®, as it not only supports the creation of a discrete-event simulation, but can also realize multi-agent systems, which is essential for modelling individual target systems.

Considering that, all processes are initially modelled at site level. Previously analysed processes and quality control loops are individually converted into a discrete-event simulation model and additional data (e.g. system load data, organizational data and technical data) is identified. For designing alternative inspection strategies, quality inspections are modelled after each process step, taking any process-specific restrictions into account. In addition, the quality control measures are defined in terms of their respective impact dimensions (e.g. production process, quality-related process, supplier, customer, transport) and influence on the parameters of the defined RPN_{ext} (e.g. increase of detection probability, decrease of replacement time). This way, alternative strategies and different process configurations can be dynamically evaluated for each individual site.

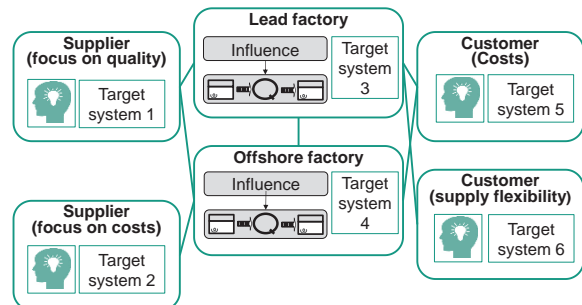

Fig. 3. Simulation of network structure

In order to model the individual decision-making behaviour of actors in the production network (company internal sites as well as external partners), target systems are defined for specific site roles and implemented as their individual function. Regarding the roles of company internal sites, a lead factory for example focuses on continuous improvements of production processes as well as a high product and process know-how as its main targets. On the contrary an offshore-factory targets an exploitation of its factor cost advantages as well as an efficient series production. Looking at external partners, target systems of suppliers could differ e.g. regarding their cost or quality focus, whereas different customer types put their focus e.g. on a high on-time delivery or on a high volume flexibility.

All actors of the specific network are transferred into a software-based agent structure, in which the identified target systems are implemented. This allows specifying a target system with local processes in accordance with its defined role for each site. By this it is acting individually. Thus, the influences of individual site roles on the quality control strategy in the production network can be formalized and the influence of different suppliers and customers on the overall behaviour of the network can be determined.

Finally, the material flow through the network including production, quality and transportation processes is realized as a discrete-event simulation model, which implements the across-site value stream. By the combination of agent-based and discrete-event simulation, the network model allows for a dynamic evaluation of different inspection strategies and discrete combinations of quality control measures as described in the following chapter.

4.3. Evaluation of quality control strategies

To evaluate different across-site inspection strategies, a specific objective function is set up for each actor according to its individual target system. Based on the analysed potentials in the first step, various combinations of inspection processes are transferred into the simulation. On the basis of the stored quality data, the results of the different inspection strategies (inspection time, inspection characteristic, inspection equipment etc.) are evaluated with respect to the target systems. As Figure 4 shows schematically, the benefit for each site as well as the overall network can be visualised.

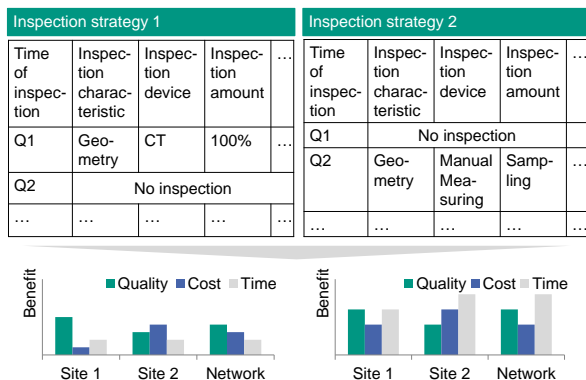

Fig. 4. Evaluation of inspection strategies

Finally, a module to systematically assess the impact of potential quality measures is developed in order to compare the potential benefit of the actions for each location as well as for the entire production network to the necessary effort for implication. The company-specific benefit as well as the effort for implementing either a quality control measure or a combination of measures can be derived from the determined target systems. The simulation model provides relevant metrics for the changed parameters of each quality measure combination, especially regarding the defined extended RPN. After each simulation run with modified input parameters, the improvement or deterioration can be quantified and, finally, the best design for combinations of quality control measures can be identified. This way, the impact is shown before the implementation of measures, so the advantages of the implementation can be ensured already in the planning phase. Figure 5 shows a potential visualisation of the implication of a quality control measure for different sites and the network in the dimensions quality, time and costs by comparing the benefit before and after the implementation of a quality measure.

In order to test the functionality of the assessment module, a simple case study is developed for a fictitious production network. In this specific scenario, the implementation of a quality improvement measure at site 1 (reduction of occurrence probability) is depicted, which results in a reduction of internal defects (improvement of quality level). Furthermore, a decrease in the quality related time can be observed, because the inspection amount could be changed from 100%-control to sampling due to the reduction of the occurrence probability. Additionally, the implementation of the measure resulted in additional costs at that site. Monitoring the effects of the implementation on site 2, it can be seen, that it has positive effects on the quality and time dimension, but leads to a significant increase regarding quality costs. Regarding the overall production network, a positive in all dimensions can be seen. Therefore, the measure should be implemented at site 1 and the benefits for the whole production network that result from this implementation should be shared across the participating sites, taking the individual target systems into account.

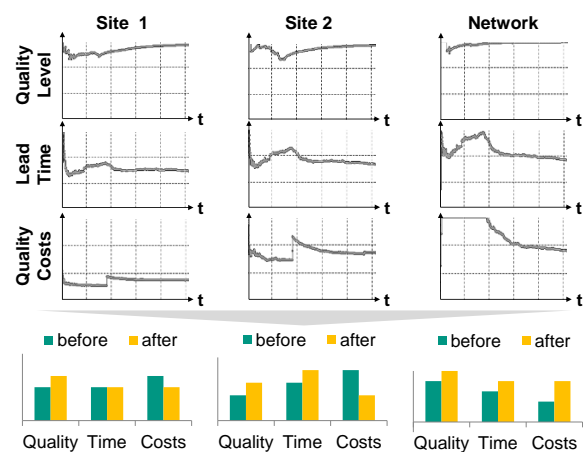

Fig. 5. Evaluation of quality control measures

5. Conclusion

Production in globally distributed production networks is becoming increasingly important. These networks can be characterized as consisting of legally independent but economically interconnected companies, which influence the overall performance of the network by their individual behaviour according to their defined site roles and respective target system. Especially ensuring the requested product quality, despite long supply chains with many partners involved, implicates special challenges in this context. In current literature there are no methods for multi-criteria evaluation of quality control strategies in production networks that take these characteristics into account. The presented three-step approach enables globally operating companies to purposefully and efficiently plan their efforts for their quality control strategy in their respective production network. In the first step, a methodology for visualization of improvement potentials in the quality control strategy is developed. In the second step, the concept of a network simulation as a combination of discrete-event and multi-agent simulation is presented, in order to model individual network structures consisting of different sites with specific site roles. Finally, the network simulation is extended by an assessment module, whereby an optimal cross-site quality control strategy can be identified.

Acknowledgements

We extend our sincere thanks to the Deutsche Forschungsgemeinschaft (German Research Foundation) for supporting this research project LA2351/28-1 „Methodik zur Bewertung der Steuerungsfähigkeit globaler Wertschöpfungsnetzwerke“ (“Methodology for assessing the ability to control global production networks”).

References

- [1] Abele E, Kluge J, Näher U. Handbuch Globale Produktion. München, Wien: Carl Hanser; 2006.
- [2] Friedli T, Mundt A, Thomas S. Strategic Management of Manufacturing Networks. Berlin, Heidelberg: Springer; 2014.
- [3] Tapiero CS, Kogan K. Risk and Quality Control in a Supply Chain: Competitive and Collaborative Approaches. *Journal of the Operational Research Society* 2007; 58: 1440-1448.
- [4] Rautenstrauch T. SCM-Integration in heterarchischen Unternehmensnetzwerken. In: Busch A, Dangelmeier W, editors. *Integriertes Supply Chain Management - Theorie und Praxis unternehmensübergreifender Geschäftsprozesse*. Wiesbaden: Gabler; 2004. p. 355–374.
- [5] Wulfsberg JP, Erasmus JH. Robuste QM-Strukturen für globalisierte Fertigungsorganisationen. *ZWF-Zeitschrift für wirtschaftlichen Fabrikbetrieb* 2007; 58: 273-279.
- [6] Czaja L. Qualitätsfrühwarnsysteme für die Automobilindustrie. Wiesbaden: Gabler; 2009.
- [7] Möller K. *Wertschöpfung in Netzwerken*. München: Franz Vahlen; 2006.
- [8] Sydow J. Unternehmensnetzwerke und industrielle Beziehungen. *Industrielle Beziehungen* 1999; 4:1-19.
- [9] Richert J. *Performance Measurement in Supply Chains*. Wiesbaden: Gabler; 2006.
- [10] Herm M. *Konfiguration globaler Wertschöpfungsnetzwerke auf Basis von Business Capabilities*. Aachen: Shaker; 2006.
- [11] Kampker A, Schuh G, Franzkoch B, Hoischen A, Bachmann F. Komplexitätsorientierte Gestaltung von Unternehmensnetzwerken. *ZWF-Zeitschrift für wirtschaftlichen Fabrikbetrieb* 2010; 105: 773-777.
- [12] Kohler K. *Global Supply Chain: Konzeption und Implementierung eines multikriteriellen Optimierungsmodells für die Gestaltung globaler Wertschöpfungsaktivitäten*. Würzburg: Julius-Maximilians-Universität; 2008.
- [13] Forster ST. Towards an understanding of supply chain quality management. *Journal of Operations Management* 2008; 26:461-467.
- [14] Kaynak H, Hartley J. A replication and extension of quality management into the supply chain. *Journal of Operations Management* 2008; 26:468-489.
- [15] Fish LA. *Supply Chain Quality Management*. In: Onkal D, Aktas E, editors. *Supply Chain Management - Pathways for Research and Practice*. Rijeka: InTech; 2011. p. 25-42.
- [16] Batson RG, McGough KD. A new direction in quality engineering: supply chain quality modelling. *International Journal of Production Research* 2007; 45:5455-5464.
- [17] Erasmus JH. *Qualitätsmanagement in global verteilten Wertschöpfungsprozessen*. Aachen: Shaker; 2008.
- [18] Das K, Sengupta S. Modelling supply chain networks: a quality-oriented approach. *International Journal of Quality Reliability Management* 2010; 27:506-526.
- [19] Macal CM, North MJ. Agent-based modeling and simulation. *Proceedings of the 2009 Winter Simulation Conference* 2009, 1:86-98.
- [20] Leitao P. Agent-based Distributed Manufacturing Control: A State-Of-The-Art Survey. *Engineering Application of Artificial Intelligence* 2009; 22: 979-991.
- [21] Giannakis M, Louis M. A Multi-Agent Based Framework for Supply Chain Risk Management. *Journal of Purchasing and Supply Management* 2011; 17:23-31.
- [22] Long Q, Lin J, Sun Z. Modeling and distributed simulation of supply chain with a multi-agent platform. *International Journal of Advanced Manufacturing Technology* 2011; 55:1241-1252.
- [23] Nyhuis P, Nickel R, Tullius K. *Globales Varianten Produktionssystem*. Garbsen: PZH-Verlag; 2008.
- [24] Haefner B, Kraemer A, Stauss T, Lanza G. Quality Value Stream Mapping. *Procedia CIRP* 2014; 17: 254-259.
- [25] Munro RA. *Six Sigma for the Shop Floor*. Milwaukee: ASQ Quality Press; 2001.
- [26] McDermott RE, Mikulak RJ, Beauregard MR. *The basics of FMEA*. New York: CRC Press; 2008.