

Project “Line Traction 3”

Mechanical driveline with active wheel hubs

Dipl.-Ing. **Danilo Engelmann**, Karlsruher Institut für Technologie,
Karlsruhe;

Werner Müller, Müller Landmaschinen, Bonndorf

Prof. Dr.-Ing. **Marcus Geimer**, Karlsruher Institut für Technologie,
Karlsruhe;

Zusammenfassung

Im Projekt Line Traction 3 wurde das Ziel verfolgt ein neues Antriebskonzept zu entwickeln. Bei diesem Konzept werden alle Räder mechanisch angetrieben ohne die Verwendung von Differentialen. Um Antriebsverspannungen bei Kurvenfahrten des Fahrzeugs zu vermeiden besitzt jedes angetriebene Rad ein Planetengetriebe um die Raddrehzahlen individuell anzupassen. Die notwendigen Drehzahlen werden für jedes Rad aus den geometrischen Daten des Fahrzeugs berechnet. Um die Funktionsfähigkeit nachzuweisen wurde ein Demonstrator ausgelegt und aufgebaut. Dieser Demonstrator wurde dann auf einen Prüfstand mit verschiedenen Tests und Manövern erprobt. Nach den erfolgreichen Tests wurde die Funktionsfähigkeit gezeigt. Am Ende sollen noch einige Ideen und ein kurzer Ausblick zeigen welche neuen Möglichkeiten durch dieses neue Antriebskonzept gegeben sind.

Abstract

The Line Traction 3 Project aims at developing a new powertrain concept. In this concept all wheels are driven mechanically without differential. This improves traction. In order to prevent tensions in the powertrain when the vehicle is driving through curves, every driven wheel has a planetary gear which adjusts the individual wheel speed with superposition. The necessary speed of each wheel is calculated with geometrical data of the vehicle. To show the functionality of this concept, a demonstrator has been planned and built during this project. This demonstrator was tested on a test rig with different manoeuvres and procedures. The tests were completed successfully and functional ability was proven. In the end, further ideas and a short outlook will reflect new opportunities associated with this new drivetrain concept.

1. Motivation

In modern mechanical powertrains of mobile machines, the mechanical differential is an established solution to distribute power. It allows the drive of several wheels and axles and ensures a theoretically tension-free turning of the vehicle. An all-wheel drive with open differential allows a defined torque distribution only and cannot always provide maximum traction force especially in rough terrain. For this reason, heavy vehicles with all-wheel drives rapidly reach their limits. Devices like differential locks or modifications in the driveline, such as fixed gear stages in middle distribution, improve the situation in cases of poor traction, but they also tend to have drive tensions even when driving straight forwards, if ground conditions are rough or axle load fluctuates [1]. So the ideal drivetrain has to ensure that every wheel reaches its maximum traction force in every situation without inducing tensions in the drivetrain when driving curves. The research project “Line Traction 3 Antriebstechnik” (LT3) was aimed at designing a mechanical drivetrain, where all wheels can be controlled actively and separately. A very important project element was the implementation of a controllable planetary gear taking into account the framework conditions of mobile machines.

2. Traction and curve radii

When a vehicle passes a curve, the wheels take on different speeds. When the wheels are driven, the drivetrain has to allow for a speed difference between the wheels moving on the outer and inner radii. If the drivetrain has no possibility to allow for speed differences between the wheels, as in case of an actuated differential lock under poor traction conditions, tensions in the transmission shafts or forced slip at the wheels are caused when the vehicle drives through a curve. As a result of this fact, the requirement was made that an ideal mechanical powertrain should have the same behaviour as a locked powertrain. While the vehicle drives straight ahead to ensure the best possible traction, the powertrain has to ensure that the relative speeds are maintained when the vehicle passes a curve. The necessary relative speeds can be calculated with the track width, wheelbase, numbers of axles, and the type of steering system. An example of a realistic vehicle with Ackermann steering and given vehicle geometry is shown in Fig. 1. This example shows the different revolutions of the wheels when the vehicle passes a curve. The same behaviour can be observed for the speeds of each wheel. For their calculation, geometrical data have to be known.

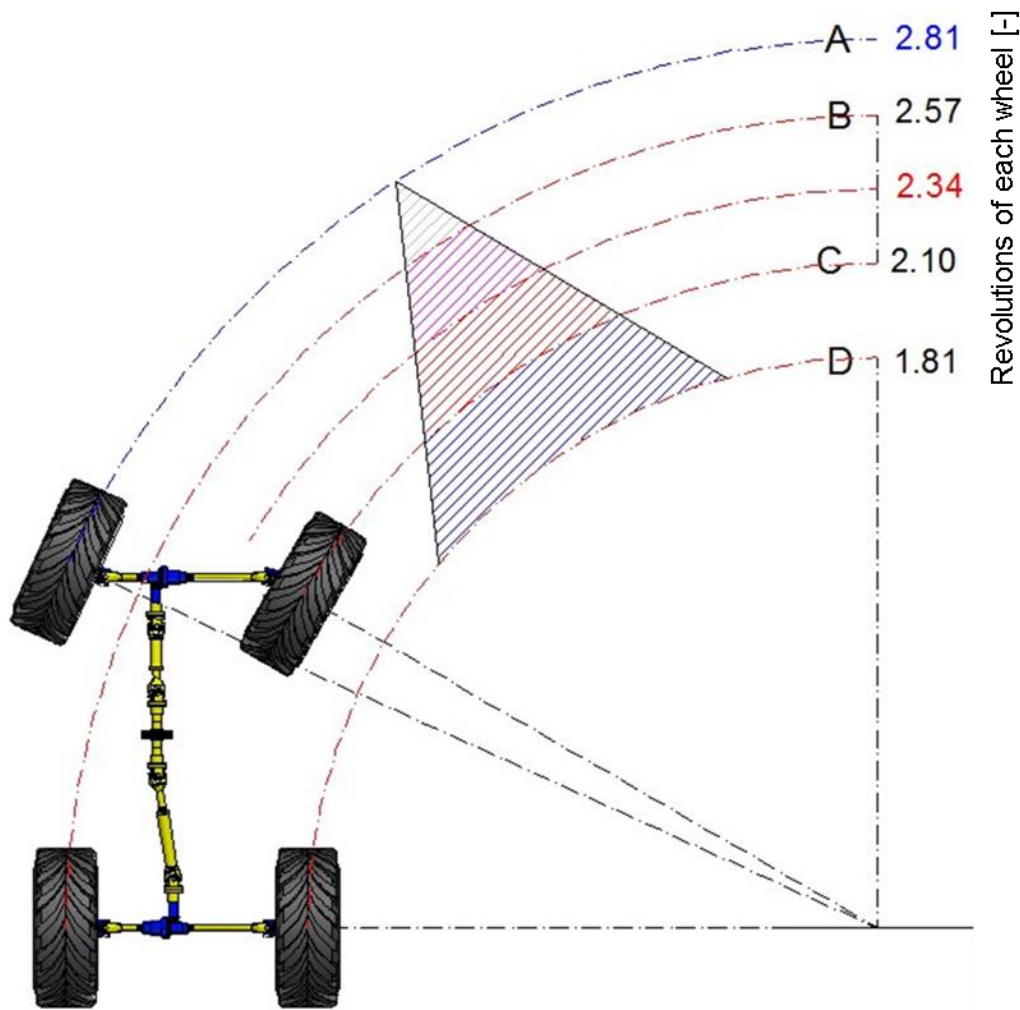

Fig. 1: Different radii and revolutions for each wheel when the vehicle drives a 90° curve.

3. Operation of the Line Traction powertrain concept

Based on the reflections made in chapter 2, the idea of the Line Traction powertrain has been developed. To meet the requirements of mobile machines, the powertrain concept was to be able to handle a large amount of power by fitting in nearly every kind of machine or axle configuration. Many machines nowadays are equipped with planetary axles or reduction planetary gears in the powertrains. In those gears the sun gear is frequently connected with the driveline, the carrier is connected with the wheel, and the ring gear is normally fixed. In the Line Traction 3 concept, the ring gear is directly connected to a hydrostatic radial piston unit acting now as the new support of the ring gear (Fig. 2, No.3). When the vehicle is driving straight, the ring gear and the hydrostatic unit remain blocked. In that case, all wheels have a transmission-proportional speed. When the vehicle drives into a curve, the wheel on the largest radius, the “master wheel,” is chosen by the electric control unit (ECU) and will not be

actuated. Based on the steering angle and the vehicle geometry, the ECU has to calculate the relative speed differences for each wheel compared to the master wheel. The reduction of speed for the corresponding inner wheels will then be reduced through the actuation of the flow control valve (Fig. 2, No.4). Immediately, the valve releases a controlled volume flow and the hydraulic unit as well as the ring gear rotate in the direction of the applied support moment. As a consequence, a superposition of speed will result in the planetary gear. Due to this, rotational speed at the wheel decreases. Thanks to the hydraulic circuit, the torque transmitted to the wheel is not affected during the actuation of the valve. The pressure follows the support torque of the ring gear, which is always proportional to the required wheel torque. The flow control valve is able to maintain the flow constant independently of the pressure. So the Line Traction concept allows for a decoupling of the wheel speeds from the rotational speed of the engine.

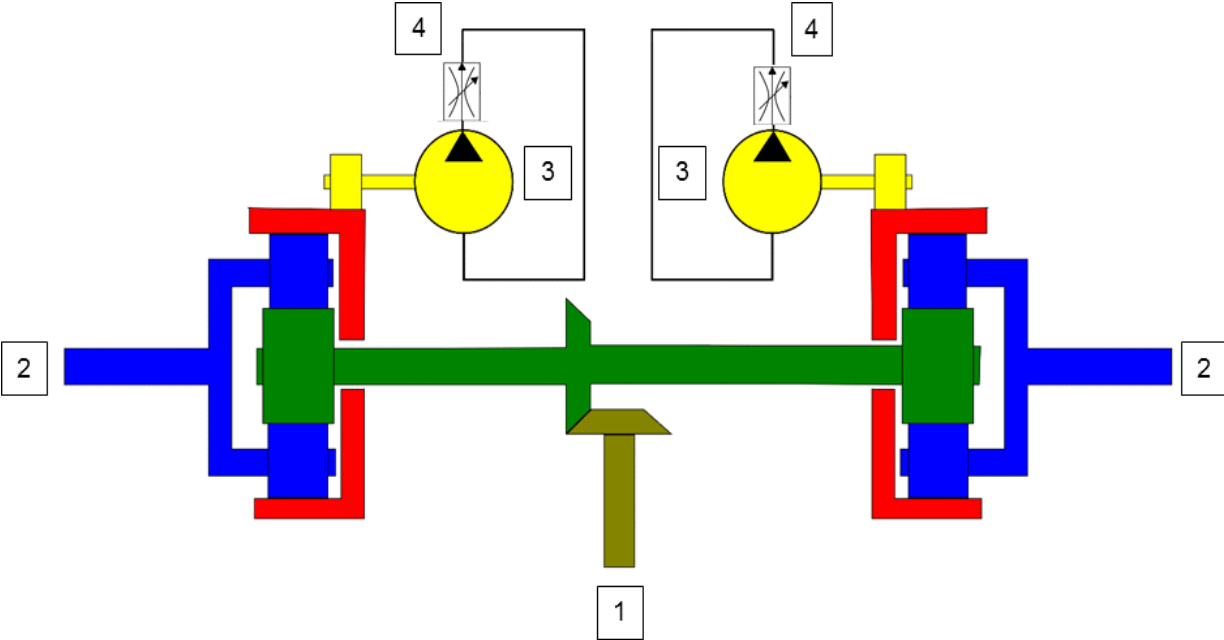

Fig. 2: Structure of the LT3 axle; 1 input shaft, 2 shaft to the wheel, 3 hydrostatic unit, 4 flow control valve. [2]

For the distribution between the axles, only fix gears are needed as shown in Fig. 1 and Fig. 2 even when the concept will be extended to three or more axles. In the whole concept no differentials are envisaged.

4. Hardware development process

An important step to verify and validate the LT3 concept was the construction of a demonstrator. Here, the focus was laid on one planetary gear with hydrostatic unit, demonstrating the function of the superposition principle. The demonstrator had to solve the trade-off between realistic vehicle conditions and extending the space concept to accommodate measurement instruments. The demonstrator represented in Fig. 3 had the specifications shown in Table 1.

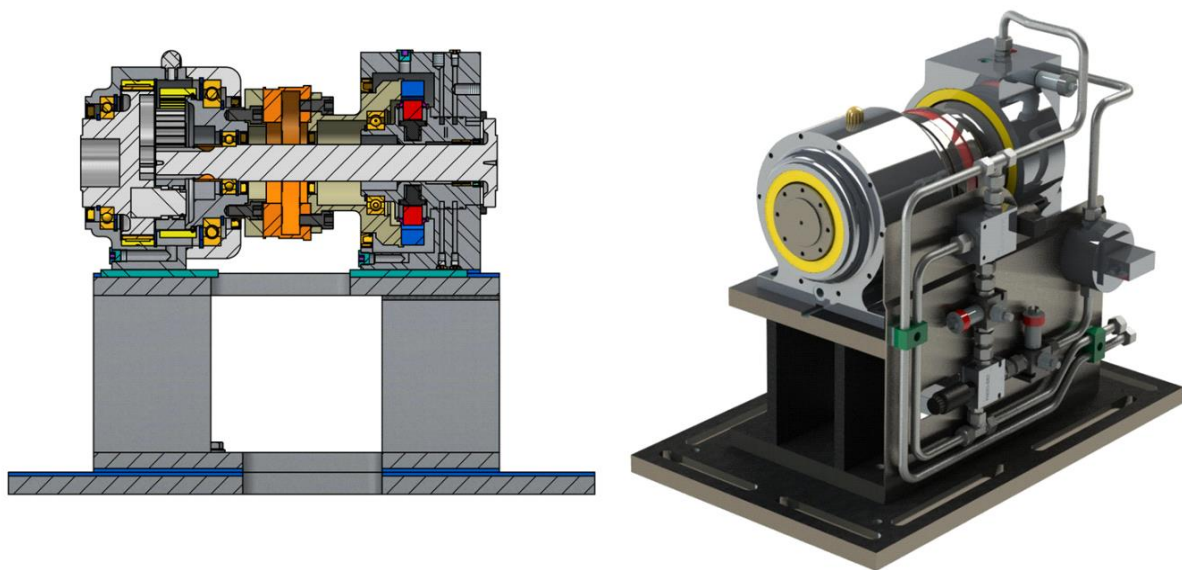

Fig. 3: Realised test bench demonstrator; left: cutaway showing the three assemblies of gears, flange, and hydraulic unit; right: the demonstrator with hydraulic circuit plate. [2]

Table 1: Technical specifications of the demonstrator

Mechanical part	
Torque at output shaft	5 000 Nm
Maximum permissible speed at input shaft	5 000 min ⁻¹
Stationary gear ratio	5 [-]
Hydrostatic part	
High pressure part of hydraulic circuit	420 bar
Low pressure part of hydraulic circuit	down to 8 bar
Flow control valve	Bucher SRCB 25 or 50

4.1 Mechanical gears

The planetary gear ensures the necessary speed superposition and power transmission to the wheels. The stationary gear ratio is freely selectable and, in our project, was chosen to

optimise the basic transmission ratio of the whole vehicle powertrain. The design of the demonstrator’s planetary gear was simplified by using a maximum of standard parts and realising the assembly in a separate housing (see Fig. 3). In this way, it was possible to integrate a telemetric torque measurement flange between the planetary gear and hydrostatic unit (Fig. 3) to measure the support moment of the ring gear. This means that it was possible to quantify and record the important data, such as torque and revolutions per minute, of every one of the three shafts. The parameters of the sun gear and carrier were logged by the test bench units. Due to the split housing design of the assemblies, the normal shaft of the sun gear was redesigned to fit into the concept and to ensure trouble-free function.

4.2 Hydrostatic unit

For the hydrostatic unit, a slim design was chosen to allow for the integration of gears and hydrostatic unit into the wheel carriers of the axles. To comply with this requirement, a radial piston unit was chosen as shown in Figs. 3 and 4.

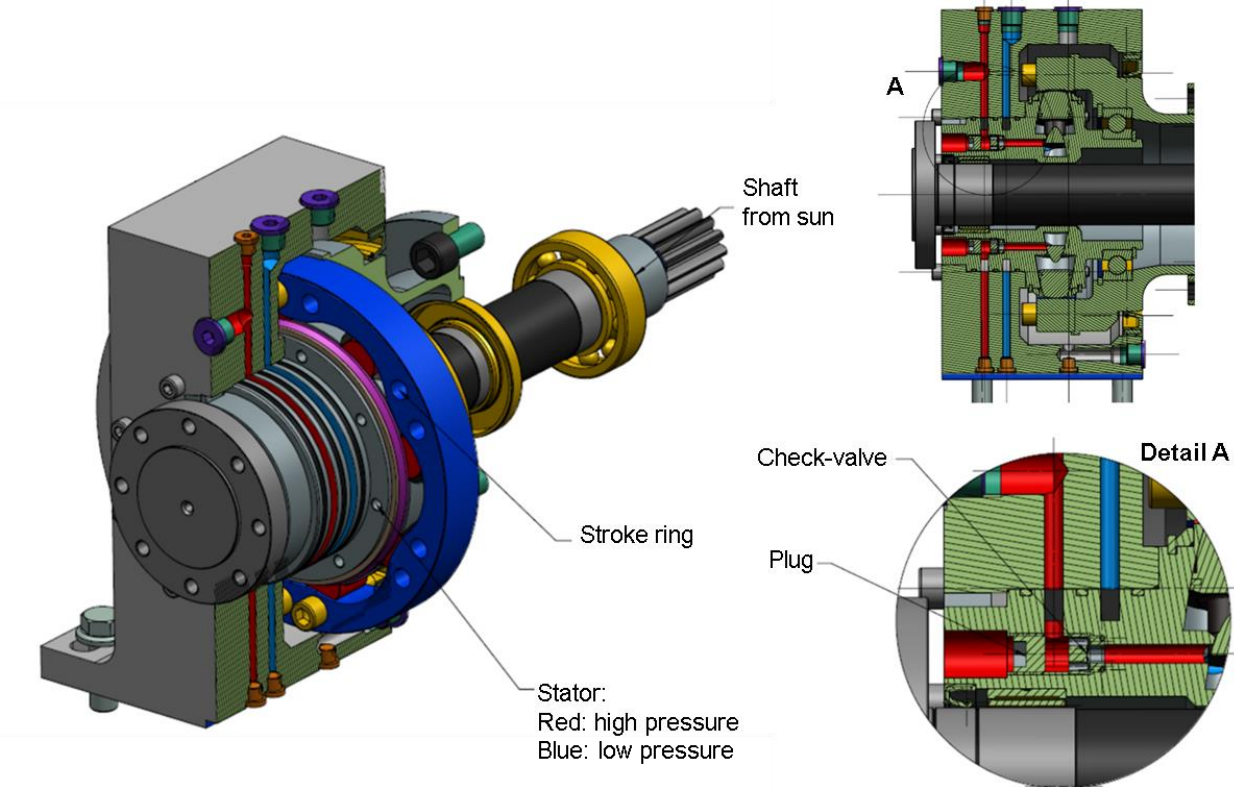

Fig. 4: Cutaways of the hydraulic unit with detailed view of the control based on check valves. [2]

To improve leak tightness and to prevent uncontrolled turning of the hydrostatic unit caused by leaks when the flow control valve was closed, the control of the hydrostatic unit was

based on check valves instead of the valve plates commonly used in radial piston machines. As a result, the sealing concept did not need any rotating or relatively moved parts except for the piston sealing rings. This reduced leakage to a minimum. Using check valves, speed superposition at the planetary gear could be influenced in any direction the vehicle is moving. The hydrostatic unit released its volume flow at any time in one flow direction, independently of the support torque of the ring gear and the corresponding turning direction of the unit, which changed with the driving direction. When actuated, the unit, hence, had hydro pump characteristics. The support torque of the ring gear was converted into pressure and volume flow was ensured by the flow control valve in the circuit.

4.3 Hydrostatic circuit

The main function of the LT3 concept is speed superposition in the planetary gear without influencing transmission of wheel torque required under the actual driving conditions. This means for the ring gear or the hydrostatic unit free turning with the necessary support torque of the ring gear being maintained under all circumstances. This task is executed by the hydraulic circuit which contains a flow control valve (Fig. 5).

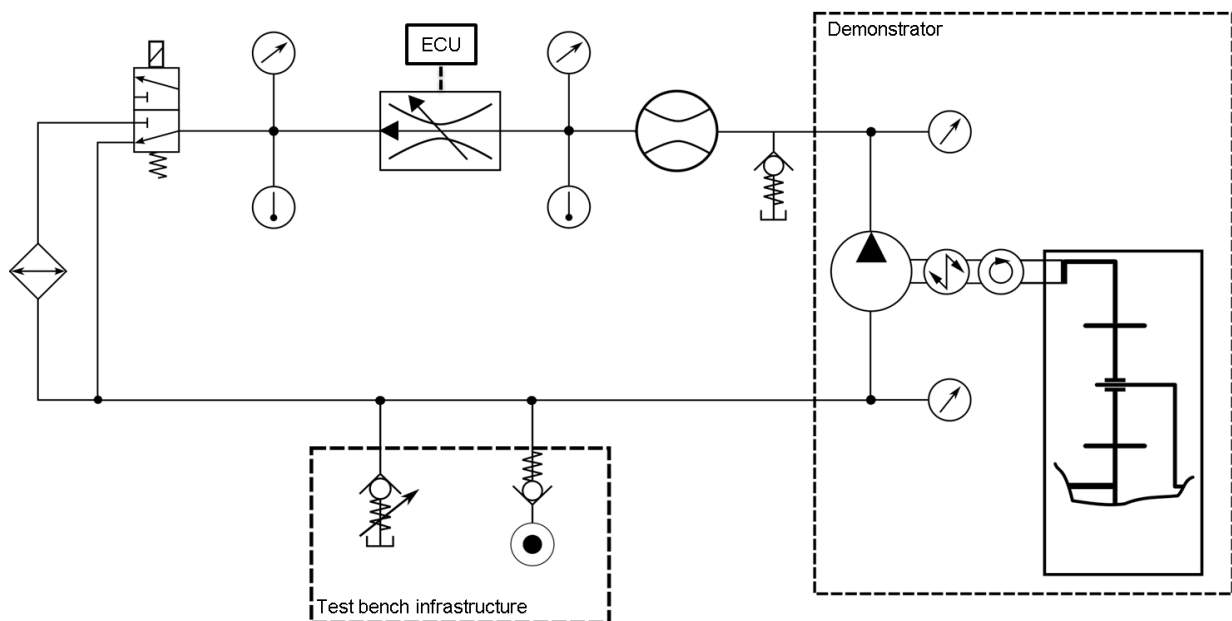

Fig. 5: First Hydrostatic circuit with the measurement equipment, flow control valve, and cooling.

The control valve controls the volume flow running in the circuit independently of the pressure generated by the hydro unit. As a consequence of the volume flow, the unit only

has the possibility to run at a certain speed. This speed is determined by the fraction of the allowed volume flow and the specific displacement.

$$n_{Ring} = \frac{Q_{VFC}}{V_s} \quad (1)$$

However, pressure build-up in the system by the support torque of the ring gear follows the equation:

$$\Delta p = \frac{2\pi M_{Ring}}{V_s} \quad (2)$$

In this way, the hydrostatic part of the LT3 concept can be dimensioned. For volume flow and the necessary speeds of the unit, the right type of flow control valve is important. The permissible pressure in the system is adjusted by choosing the right displacement for the hydrostatic unit, when the necessary superposition speeds and torques are given by the vehicle concept. In the demonstrator, the circuit was accommodated on a separate plate (Fig. 3) to ensure good accessibility of all parts and integrate all necessary measurement instruments. This large amount of sensors was used to log the states of the hydraulic system during the tests. In a concrete vehicle application, the amount of sensors may be reduced. The low-pressure range was adjustable from 0 to 25 bar. In practice, the demonstrator was operated at 6-8 bar, depending on the speed of the hydrostatic unit. Back feeding was accomplished by a central pressure supply system. A 3/2-way control valve allowed for operation with or without an additional cooler.

5. Test runs

After assembling all parts, the demonstrator was put on the test bench. Two electric machines were used to simulate the drivetrain and the load, as is shown in Fig. 6. Investigation was aimed at validating the idea of the LT3 concept in terms of hardware and at making a system identification to generate data for the calibration of a physical simulation model. The simulation model was set up during the construction process of the demonstrator.

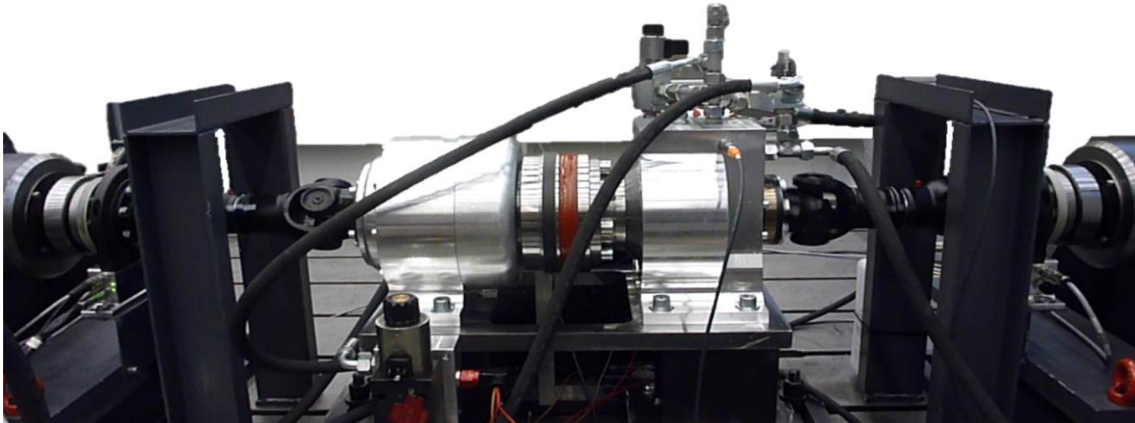

Fig. 6: Demonstrator during a test run on the test bench.

The demonstrator was loaded stationarily with different speeds and torques without actuating the volume flow control valve in the first step. In the second step, different stationary points in speed and torque were given and volume flow was increased in a stepwise manner until the maximal flow rate was reached. After these first test runs to demonstrate the function and operability of the demonstrator, further investigations were conducted. For example, steady-state temperature tests were run to observe whether heating up of the hydraulic oil had an impact on the support of the ring gear. Such an effect could not be identified, however, as long as the demonstrator was operated such that the oil was used in accordance with its thermal specifications. One important test was to observe the step function response (Fig. 7).

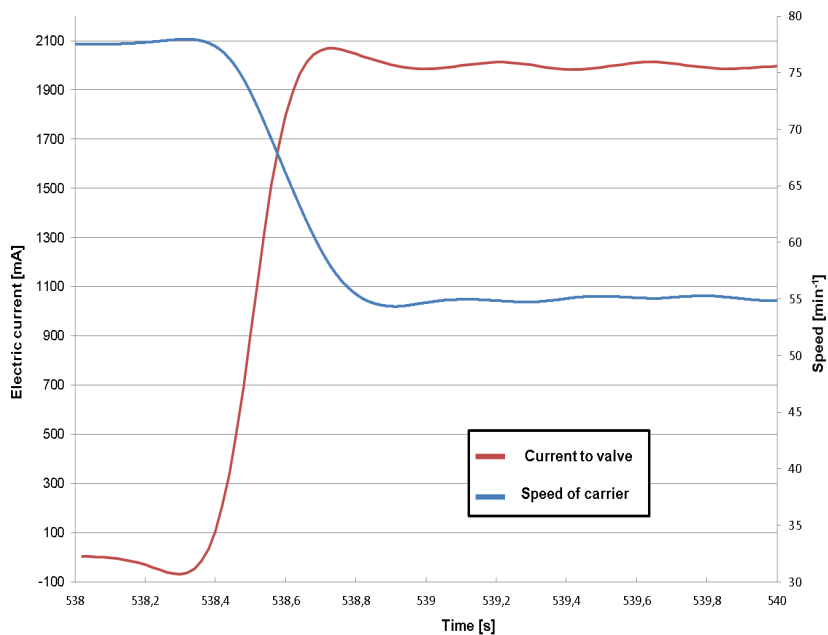

Fig. 7: Step function response of the demonstrator: the electric current to the valve is shown in red, the speed of the carrier is coloured blue.

The step function was generated by the electronic control unit (Fig 5) sending an electrical signal to the volume flow control valve and the speed of the carrier being observed. The time from initial speed to the steady-state speed was 0.4 s. This time was reproduced in all tests with same starting conditions.

Furthermore, some open-loop tests were performed with the ECU in order to simulate a realistic manoeuvre of the demonstrator under vehicle conditions. The ECU created a turning manoeuvre with dynamic ramps by simulating a driver through increasing the steering angle, holding it, and then decreasing it. This was transformed into an electric signal as input for the demonstrator. As shown in Fig. 8, the demonstrator followed the given input without considerable delay even when the dynamics was increased by increasing the final steering angle in the same time span as in the manoeuvre before.

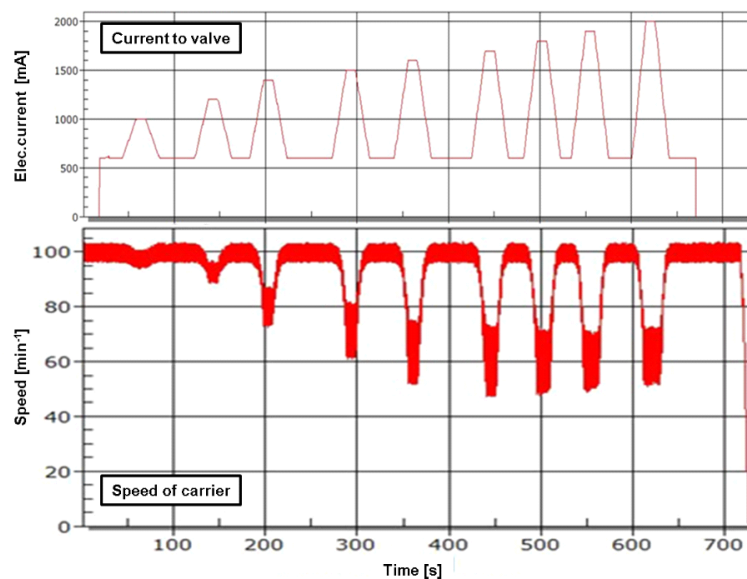

Fig. 7: Steering simulation of the demonstrator. Upper plot: the electric current to the valve, lower plot: speed of the carrier.

6. Conclusion

The project has shown that the initial idea of optimising the traction of mobile machines by replacing the differential in powertrains by the LT3 concept will work. When using the LT3 concept, the torque is distributed to the powertrains according the whole traction force potential of each wheel is used. This idea led to the construction of a powertrain concept using the planetary gears existing in most of the mobile machines so as to prevent tensions in the axle shafts when driving through a curve. This concept was adapted to the space conditions commonly found in the machines. The demonstrator was constructed and set up on a test bench for investigation. The results of the investigations verified the hypothesis. Through the fast reactions of the current system status in a vehicle, even if the current size of the system is enlarged due to additional measurement instruments. For a concrete application, a more integrated version could be realised, as long as all parameters

influencing the function of the system are identified. In this way, the ideal configuration would be found for the concrete application independently of the number of axles with or without planetary gears.

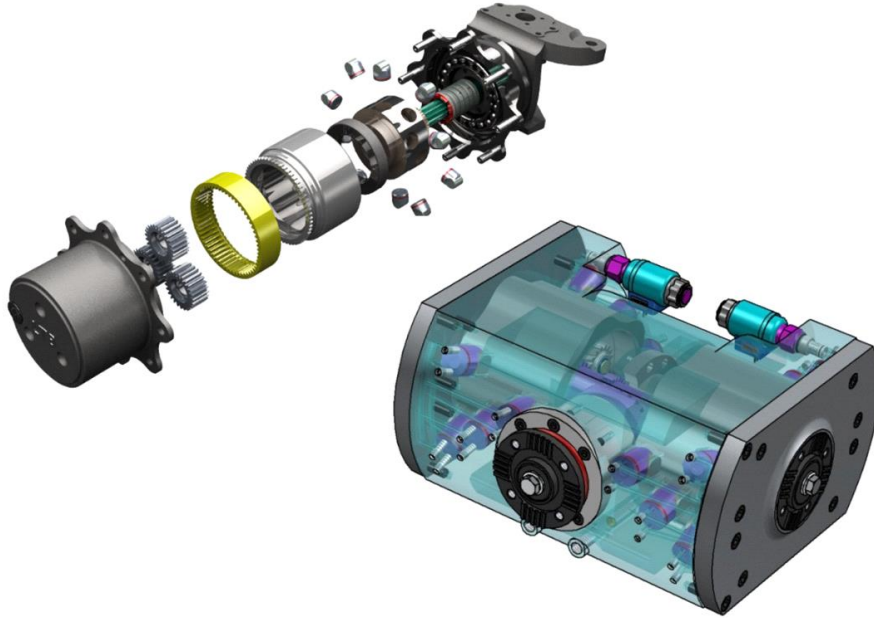

Fig. 8: Part studies of the LT3 concept. On the left side: a highly integrated wheel hub version, on the right side: replacement for the differential space.

7. Outlook

The project did not only serve to demonstrate the functionality of the system. In addition, other side effects were observed. When a torque is acts on the ring gear, the system builds up pressure and the wheel torque can be measured or estimated at least. In this way, it is possible to determine the driving wheel torque or internal stress in the drivetrain during standstill by a simple pressure measurement (Eq. 2). This could open new possibilities of controlling the drive state or the state of the powertrain. Another new possibility is the use of hydraulic instead of clutch systems known from passenger cars. To use the hydraulic system in passenger cars and to give the LT3 system a torque-controllingfunction, the volume control valve has to be replaced by a pressure control valve. Then, the system will change from a speed-controlled system to a torque-controlled one. This would allow for torque vectoring or steering assistance of mobile machines by the drivetrain (Fig. 9). Especially the steering assistance aspect should be further investigated to improve driving performance and safety. This could lead to an improved machine effect.

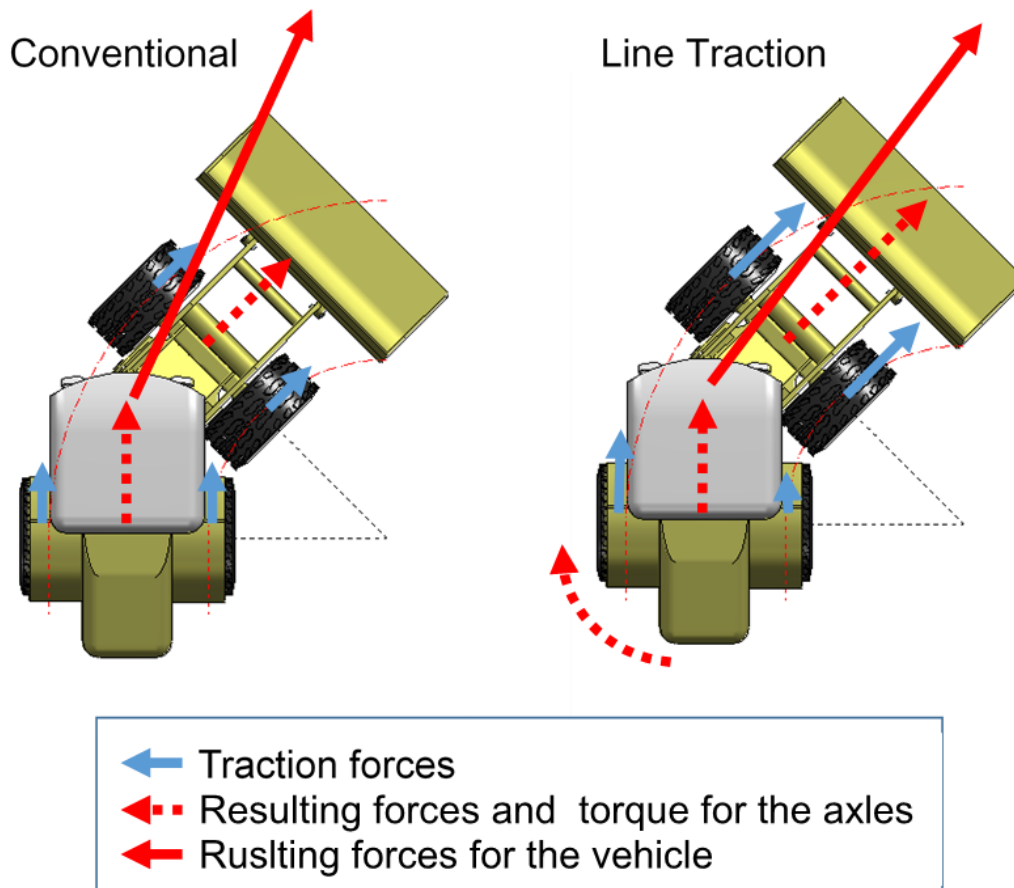

Fig. 9: Idea of assistant system with the LT3 concept; left side: conventional powertrain, right side: vehicle with LT3.

Acknowledgement:

The authors would like to thank the Federal Ministry for Economic Affairs and Energy for funding the project based on a decision by the German Bundestag. Special thanks also go to the company ifm electronic for supporting the project.

[1] Huber,A: Ermittlung von prozessabhängigen Lastkollektiven eines hydrostatischen Fahrtriebsstrangs am Beispiel eines Teleskopladers. Karlsruhe. Karlsruher Institut für Technologie, Dissertation,2010

[2] Engelmann,D, Müller,W; Müller,J; Geimer,M: Anforderungen an den Antriebsstrang eines schweren Nutzfahrzeugs. ATZoffhighway 02/2015 S. 26-37