

This is the author's version of a work that was published in the following source:

Jochem, P.; Landes, P.; Reuter-Oppermann, M.; Fichtner, W. (2016).

[Workload patterns of fast charging stations along the German Autobahn](#) 

*Proceedings of EVS29 Symposium.
Montréal, Québec, CDN, June 19-22,
2016, EVS, Washington, D.C.*

Please note: Copyright is owned by the author(s) and / or the publisher. The commercial use of this copy is not allowed.

Workload Patterns of Fast Charging Stations Along the German Autobahn

Patrick Jochem¹, Philipp Landes¹, Melanie Reuter-Oppermann¹, Wolf Fichtner¹

¹Karlsruhe Service Research Institute (KSRI) at the Karlsruhe Institute of Technology,
Englerstraße 11, Karlsruhe, 76131, Germany

Summary

We analyze daily charging demand patterns of electric vehicles at DC fast charging stations along the German autobahn for an average week in 2020. For this we develop an agent based simulation tool based on current empirical mobility data. Our results show that already in 2020 about 1,000 charging processes per charging location and day might be realistic. In order to avoid long waiting times these charging locations should be equipped with about 20 charging points. A utilization rate of up to 80% makes a profitable operation of these stations highly probable. A sensitivity analysis indicates main parameters which influence the throughput of electric vehicles significantly.

Keywords: Infrastructure, EVSE, fast charge, simulation, Germany

1 Introduction

The roll-out of charging stations was seen as a necessary requirement for a successful market uptake of electric vehicles (EV). However, the need of public charging was overestimated, because most trips are within a small range and users charge their EV mostly at home or at the working place [1]. Only for seldom trips to neighboring cities or long-distance trips, charging is still challenging. For the first application, public accessible Mode 3AC charging stations (cf. IEC 16851) are sufficient, whereas for the second application, the long-distance trips, time is scarce, and therefore, Mode 4 DC fast charging stations should be applied. The latter is currently high on the political agenda in Europe and it is the focus of this paper. The rollout of the fast charging system is a severe investment for the future mobility system with EV and their optimal allocation is of high value for the society.

We base our analysis on an existing scenario, which shows an optimized allocation of fast charging stations along the German highway in Southern Germany (80% coverage of all trips with 100 km range) [2]. In this paper we simulate the daily workload pattern of selected charging stations in order to estimate the required number of charging points per charging location during peak-times. We develop an agent based model to simulate the charging demand by EV during a week in 2020. The results of our analysis are significant for three research areas: (1) The number of charging points considerably influences the cost estimates for the rollout of the fast charging infrastructure system and (2) impacts the waiting time of EV users at these charging locations and (3) the peak in electricity demand is relevant for dimensioning the electricity grid connection. Hence, the endowment of charging points is important and, consequently, the objective of this paper is to give an estimate of an adequate number of charging points per fast charging location along the Autobahn in Southern Germany with respect to costs and waiting time of EV users.

The structure of the paper is as follows. Firstly, we give a short introduction into the applied data and our agent based model. Secondly, we present our main results, a sensitivity analysis, and corresponding discussions. The conclusions and outlook complete our paper.

2 Method

In order to estimate the adequate number of charging points per fast charging location along the Autobahn in Southern Germany with respect to costs and waiting time of EV users, we first analyze the workload of long distance trips over time in Germany. Unfortunately, this data is only available on the national level. However, together with disaggregated traffic flow data for each intercept the specific workloads for each highway exit can be estimated. Based on this data, the simulation model is projecting the waiting time of EV for each time interval of the week.

2.1 Data

The workload of long distance trips in Germany is taken from the most recent dataset “Mobilität in Deutschland” [3]. This data is based on a survey in 2008 and 2009 on traffic information of over 100,000 people. As the surveys’ participants did not only use highways, an adjustment of the data set was necessary. Therefore, we assume that car trips above 45 minutes and more than 25 km or car trips with more than 50 km are highly probable applied on highways or at least on motorways. In the database the departure and arrival times for all trips are known on a minutes-based time resolution. However, the information from the survey participants are biased to quarterly values (i.e. 12.00, 12.15, 12.30 or 12.45 o’clock). We, therefore, transferred all values into 15-minutes time-slices and scaled this pattern to the traffic volumes at each highway exit. The resulting normalized workload pattern of the 672 time-slices during a week can be seen in Figure 1.

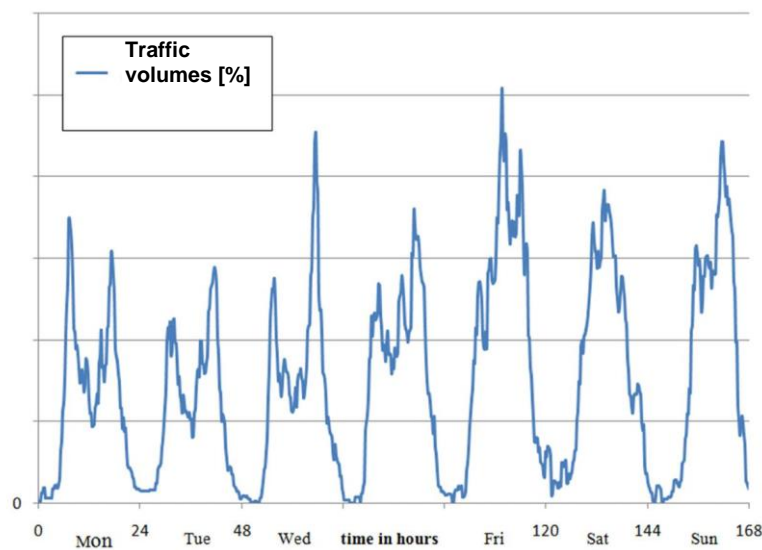

Figure 1: Normalized workload pattern of long-distance trips in Germany during a week.

This workload pattern during an average week indicates that the highest appearance of traffic occurs during Friday afternoon, which represents the peak-load demand for our analysis of fast charging stations along the German Autobahn. In order to estimate the corresponding number of charges at a charging location, the calculated traffic volume during Friday afternoon is multiplied with the estimated share of EV in 2020 (i.e. 2.25 %). This corresponds to the target by the Federal Government of 1 million EV [4]. Because the average distance between charging stations in our scenario is around 50 km, we expect that about 50 % of EV charge at each charging station along their long-distance trip. Together with the described traffic flow pattern over a week, we estimate the number of expected vehicles arriving per minute including a Poisson-distributed error term with a Lambda of 1.

2.2 The applied agent based model

In order to analyze daily charging demand patterns of EV at fast charging stations, we built an agent based simulation with the simulation software AnyLogic. In our agent based model, each agent is an active object which interacts with all other model elements. E.g. each EV is represented by a single agent with specific parameters. Each charging location is simulated separately. EV agents are generated according the location specific workload patterns and enter the simulation with its individual parameters. They wait in the queue (“holding point”) if all charging points are occupied (cf. Figure 2). If not, they directly proceed to the first free charging point (“enter”). They leave the queue according the first-in-first-out principle and proceed to the next free charging point. We consider up to twenty charging points for one charging location in the simulation.

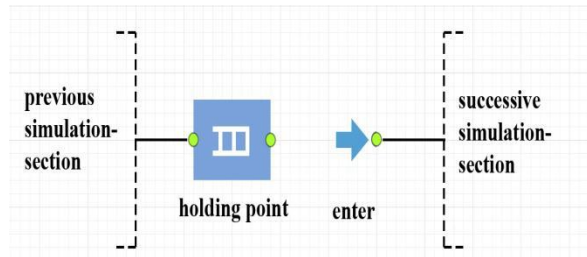

Figure 2: EV queuing at the charging location.

As soon as an agent arrives at a charging point, the charging process starts. Their charging duration depends on the charging demand and maximum charging rate. We assume that the charging demand and the charging rate on highways are similar for all EV. Consequently, we take a constant net charging duration (NCD) for all agents. However, there might be significant differences in the gross charging duration (GCD_i) due to different user behavior etc. (cf. eq. 1). We therefore consider two additional parameters. Firstly, we consider a variance in the NCD (ϕ_i , which is a uniformly distributed error term between 0.8 and 1.2). Secondly, we introduced a second summand for more pessimistic scenario calculations, which consider an additional estimated waiting time (WT) and again a uniformly distributed error term (ε_i). In the following we assume an additional waiting time of 2 minutes ($WT = 2$) and an equally distributed error term between 0 and 2. The additional waiting time might be caused by forgetfulness of customers or other reasons. With a charging demand of 16 kWh and a maximum charging rate of 100 kW but without an additional waiting time, the GCD are between 7.68 and 11.52 minutes. Due to the high amount of vehicles generated in our simulation the deviation between two runs of the same instance is smaller than 0.5 %.

$$GCD_i = NCD * \phi_i + WT * \varepsilon_i \quad (1)$$

Figure 3 gives an overview of the simulation model and its main output options, which are provided by several measuring points between the entering of the charging location (“start”) and the departure (“exit”). They measure e.g. the overall charging duration for each agent and the total amount of charging events. All these numbers are simultaneously exported in separated output files, which allow further ex-post evaluations. Some selected results are given in the following section.

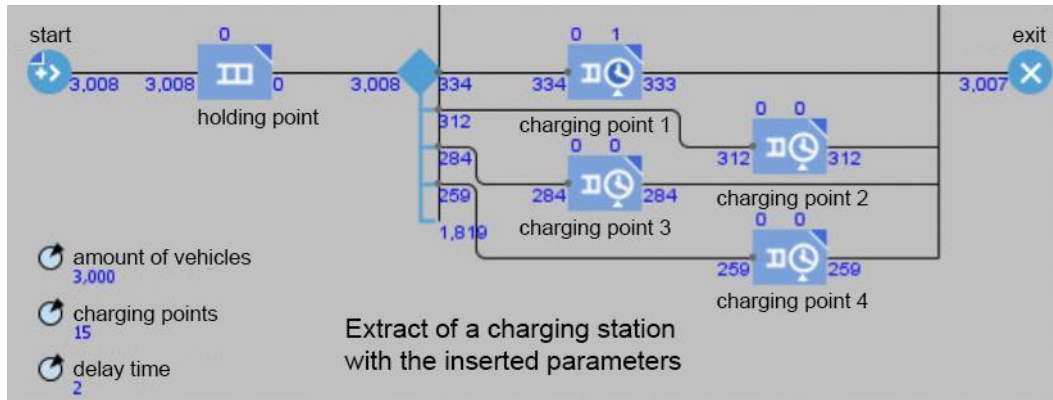

Figure 3: Outline of the agent based model architecture.

3 Results

In the following, we first present our main modelling results focusing on the charging station, which is most utilized in the considered model region. In our calculation, we applied several assumptions, which are associated with significant uncertainties. Therefore, we applied a sensitivity analysis, which is presented at the end of this section.

3.1 Modelling results for the charging station with the highest electricity demand

At the charging location with the highest electricity demand the investment, the expected electricity load, and waiting time is assumed to be highest. We therefore focus on the highway exit of Böblingen from the highway No A81. Based on the driving patterns from the mobility data (cf. section 2.1), the corresponding electricity demand per minute by the vehicles is considered by our agent based model (cf. section 2.2).

The traffic flow at this exit is 94,258 passenger cars per day. Based on the assumed market share of EV in 2020 we estimate 2123 EV (or 1062 charging events) per day. Furthermore, the average charging time is 9.6 minutes (see above). Initially, we assumed to have 20 charging points per charging location.

The resulting waiting time for the Böblingen location under perfect conditions is for most hours during the week not non-existent – but exceeds almost 20 minutes during Friday afternoon, when long-distance commuting, holiday and leisure trips are most probable. Utilization hours for this charging location amount to about 75 %. If the additional waiting time WT and the error term ϵ_i is considered: The gross waiting time on Friday increases up to one hour (cf. Figure 4) and the number of waiting EV exceeds 100 in our scenario. Consequently, for this second scenario, the amount of charging points at the charging location becomes insufficient for Fridays. The increase in average waiting time increases only slightly from 9.6 to 11.6 minutes.

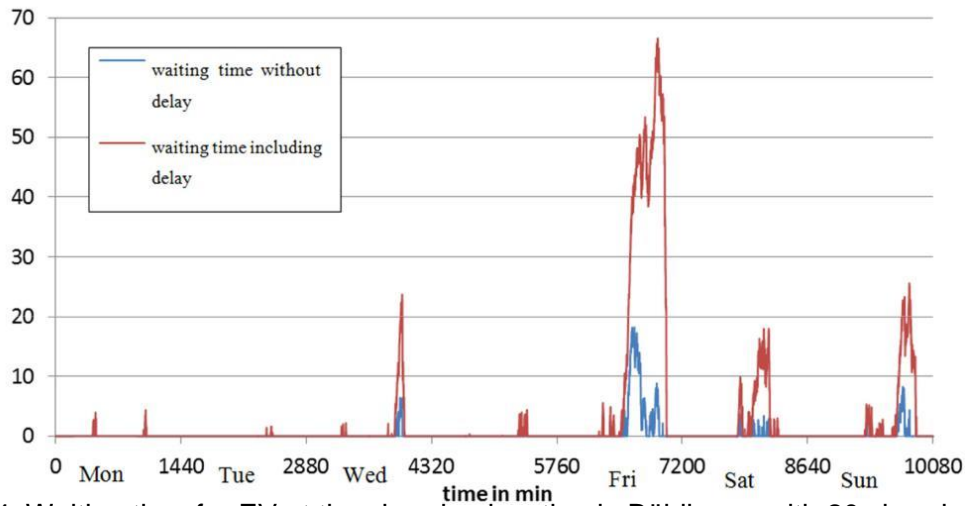

Figure 4: Waiting time for EV at the charging location in Böblingen with 20 charging points over time.

As mentioned above, our assumptions for 2020 are highly uncertain and the sensitivity of results seems to be very high. Therefore, we present in the following a sensitivity analysis for two main parameters: charging time and EV per hour.

3.2 Sensitivity Analysis

Firstly, we altered the parameters “traffic flow” and “gross charging time” for our example highway exit Böblingen. As assumed, we identified a high sensitivity of our results: An increase of 10 % in gross charging time leads already to significant rise in average (150 %) and maximum (100 %) overall charging time. An increase of 10 % in traffic volumes leads to similar values (150 % and 200 %, respectively). Secondly, we changed the number of charging points per charging location. The corresponding result indicates that a decreasing number of charging stations has a very strong effect. Subtracting one charging point leads already to an increase in waiting time of 50 % and two charging points even double the waiting time at this charging location (cf. Figure 5).

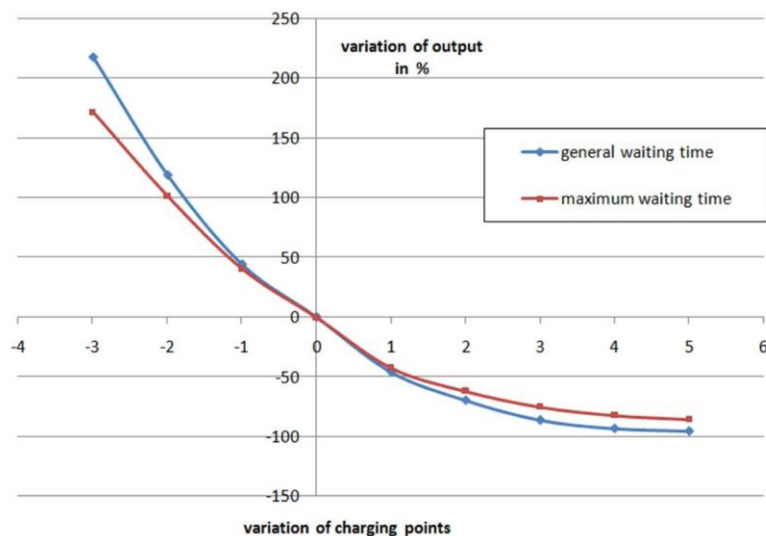

Figure 5: Results of sensitivity analysis for number of charging stations.

We conclude that the assumptions on traffic flows, charging time (including blackouts of charging points), and the number of charging stations have a highly sensitive impact on the scenario results.

3.3 Discussion and critical appraisal

Even though the required number of charging points is similar for several other charging locations in our model, the results depend strongly on our assumptions. Especially regions with a higher market penetration on EV users, unexpected outages of charging points or an extended charging duration (due to limited charging power or prolongation due to unreliable users) have a severe impact on our results. It might be helpful to automate plugging of EV (e.g. via inductive charging accompanied with a smartphone application, which indicates the state of charge) in order to keep the flow-through of EV high. Furthermore, the assumption that the share of EV on the highway equals the market share of EV in Germany is highly questionable. Currently, most EV are rather used in local traffic. Comprehensive sensitivity analysis with such parameters is highly recommended before charging stations are installed.

The connection to the high voltage grid (110 kV level) is costly and the distances differ significantly. We, therefore, analyzed the average distance to (a transformer of) the high voltage grid level from all German highway exits. The average distance is about 1.7 (5) km. This leads to an additional average cost for the grid connection per charging location of about 1 million euros. For the 20 kV level, the required distances might be even shorter. However, it is questionable, if the 20 000 voltage grid level can cope with the future electricity demand if (almost) all passenger cars are replaced by EV. Even in our scenario for only 1 million EV, the peak load increases to 2 MW (20 charging points à 100 kW) each day during peak hours (whenever waiting time occurs). With regard to a complete market penetration of EV, a connection to the 110 kV level seems more sustainable.

Further research might focus on the impact during holiday times, where the peak-demand might even increase. Furthermore, it might be worth to investigate the impact on the whole energy system. This includes especially an impact analysis from peak-load by fast charging stations on the already existing grid bottlenecks in the highest-voltage grid level in Germany.

4 Conclusions and Outlook

Our results show, that the number of charging points per charging location is highly relevant with regard to the investment on the fast charging network, waiting time, and impact on the electricity grid. According to our assumptions, the workload at fast charging stations along the German Autobahn in 2030 is already considerable. Hence, a profitable operation of these charging stations seems realistic even for small market shares of EV. We analyzed the forecasted load patterns of the most frequently used fast charging location at the highway exit in Böblingen in 2030. The results of our agent based simulation indicate that the waiting time for charging is negligible for most of the week. However, for Friday afternoon, the waiting time might be severe (up to one hour) and the number of charging stations should be configured for this peak-demand (which means an overcapacity for the rest of the week).

The results do, however, depend on several assumptions (which are given in the paper). Further research should improve the consideration of cost components and integrate the impact on the (local) 110 kV grid because the corresponding electricity demand might lead to maximum loads of up to 2 MW, which is equivalent to a small wind farm.

Acknowledgments

The research was made possible as part of the project IILSE funded by the German Federal Ministry for Economic Affairs and Energy (FKZ 01MX15004). We would like to thank Maximilian Gras for supporting us with the estimation of cost parameters for the connection to the electricity grid.

References

- [1] National Electric Mobility Platform (NPE), Fortschrittsbericht der Nationalen Plattform Elektromobilität (Dritter Bericht), Berlin http://www.elektromobilitaethamburg.de/riot-utils/download/media/0/841169574_51500/fortschrittsbericht_npe_3_bericht.pdf, accessed on 2016-02-20.
- [2] P. Jochem, C. Brendel, M. Reuter-Oppermann, W. Fichtner, S. Nickel, Optimizing the allocation of fast charging infrastructure for electric vehicles along the German Autobahn, Journal of Business Economics, doi: 10.1007/s11573-015-0781-5 (accepted).
- [3] Infas (Institute for Applied Social Sciences) and DLR (German Aerospace Center), Mobilität in Deutschland, project report, (2010), Berlin, Deutschland, www.mobilitaet-in-deutschland.de, accessed on 2016-02-20.
- [4] German Federal Ministry of Economics and Technology, (2009), German Federal Government's National Electromobility Development Plan, <https://www.bmwi.de/English/Redaktion/Pdf/national-electromobility-development-plan,property=pdf,bereich=bmwi,sprache=en,rwb=true.pdf>, accessed on 2016-02-20.

Authors



Patrick Jochem is research group leader at the KIT-IIP, -DFIU, -KSRI, and chair of energy economics. In 2016 (2009) he received his habilitation (PhD) in energy economics (transport economics) from KIT. He studied economics at the universities in Bayreuth, Mannheim and Heidelberg, Germany. His research interests are in the fields of electric mobility and ecological economics.



Philipp Landes studies industrial engineering at the KIT since October 2012. Currently he expands his experiences in the field of electric vehicles and energy management at the Daimler AG in Düsseldorf, Germany.



Melanie Reuter-Oppermann is a research assistant in the group of Discrete Optimization and Logistics at the Karlsruhe Institute of Technology (KIT). She joined the Karlsruhe Service Research Institute in 2011 and since 2014 she is a senior research associate and in charge for the healthcare services group. She studied Economathematics at the Technical University Kaiserslautern.



Wolf Fichtner is director of the Institute for Industrial Production (IIP), the French-German Institute for Environmental Research (DFIU) and the Karlsruhe Service Research Institute (KSRI). He is full professor and holder of the Chair of Energy Economics at KIT. His main areas of research are energy system modeling and the techno-economic analysis of energy technologies.