

Mercury ring pump proof-of-principle testing in the THESEUS facility



T. Giegerich*, C. Day, M. Jäger

Karlsruhe Institute of Technology, 76344, Eggenstein-Leopoldshafen, Germany

HIGHLIGHTS

- The KALPUREX process is the baseline vacuum pumping process for an EU-DEMO.
- In the KALPUREX process novel rough vacuum pumps are foreseen for continuous and non-cryogenic torus exhaust pumping.
- The pumps used in KALPUREX are pumps are Liquid Ring Pumps (LRPs) with mercury as working fluid.
- KIT has developed a prototype pump in collaboration with industry and did proof-of-principle tests in the THESEUS facility.
- The results of these experiments, as well as lessons learned for a pumping system design, will be presented here.

ARTICLE INFO

Article history:

Received 30 September 2016
Received in revised form 8 February 2017
Accepted 19 March 2017
Available online 4 April 2017

Keywords:

DEMO
Vacuum pumping
Mercury ring pump
THESEUS facility
KALPUREX process
Fuel cycle

ABSTRACT

For the DEMO torus vacuum system, liquid ring pumps (LRPs) with mercury as working fluid have been proposed. These vacuum pumps shall be used for pumping the torus down to a pressure <100 Pa and for providing rough vacuum for the torus primary pumps. Unfortunately, liquid ring pumps operated with mercury have never been built and tested before, so no operational experience is available. It is not even clear if the pump will work with such a high density working fluid or if the pump can withstand the high mechanical forces. Therefore, proof-of-principle-testing has become necessary. This is the very first step in the development of a DEMO relevant LRP that is hermetically tight and fully tritium compatible.

The paper describes the proof-of-principle experiments that have been performed in the THESEUS pump test facility at KIT and its results. Special focus of the paper is given to operational aspects as well as to mercury handling procedures. The impact of these findings on the design of future LRPs in a DEMO relevant design is shown up and modifications of the existing design are proposed.

© 2017 The Authors. Published by Elsevier B.V. This is an open access article under the CC BY-NC-ND license (<http://creativecommons.org/licenses/by-nc-nd/4.0/>).

1. Introduction

The reduction of tritium inventories is a key challenge for future fusion power plants, mainly due to economic reasons (high costs, limited availability) and safety and licencing issues (radioactive inventory, explosion risks). Main contributor to the overall inventory in fusion reactors is the fuel cycle including the vacuum pumps that work batch-wise and thus accumulate tritium (when assuming a ITER-like, cryogenic pumping solution [1]). The step towards a continuously working, non-cryogenic pumping solution would thus be a high benefit. This is why KIT has developed a new vacuum pumping process, the KALPUREX-process [2]. In this process, diffusion pumps are applied as primary pumps and liquid ring pumps as roughing pumps, both using mercury as working fluid to make them tritium compatible [3]. For diffusion pumps, it is well known

that they work with mercury as it was the very first fluid used in this kind of pump [4]. For liquid ring pumps, this is unknown and can only be postulated as no reasons against this concept could be found [3]. However, it has never been demonstrated and it would be an unacceptable high risk to rely on this assumption without any further validation. Therefore, it was decided to start a proof-of-principle test activity.

2. Scope of this work

In this work, a proof-of-principle test will be presented using a mercury-adapted, but otherwise commercial liquid ring pump design. Scope of this test was the demonstration of liquid ring pump operation with mercury as working fluid. Also included is a critical assessment of the operational behaviour of the pump and the identification of operational limits (like critical rotor speeds and achievable ultimate pressures). In addition, performance tests have been done and the results analysed, identifying weaknesses in the commercial pump design if used with mercury and fields

* Corresponding author.

E-mail address: thomas.giegerich@kit.edu (T. Giegerich).

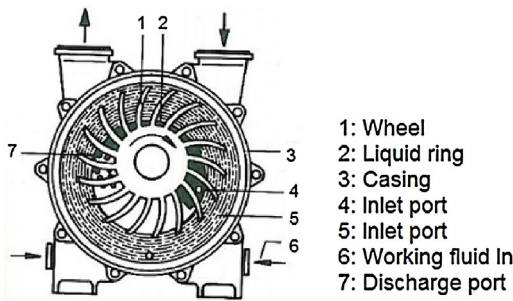

Fig. 1. Working principle of a liquid ring pump [5].

of improvements. Also experiences in handling mercury will be presented here and the impact on the design of future pumping systems will be discussed.

3. Liquid ring pump proof-of-principle testing

3.1. Description of the test pump

The liquid ring pump used for proof-of-principle testing has been developed in cooperation with an industrial company (Hermetic-Pumpen GmbH, Gundelfingen, Germany) that is specialized on full stainless steel liquid ring pumps. A stainless steel pump is required to ensure a low tritium permeability. The basic working principle of the pump is being described in [5] and shown in Fig. 1.

The test pump design is based on a modified water ring pump type LVPM600 where the following modifications have been implemented. A different electric drive was included that allows to operate the pump at only 400 rpm but at higher torque. The reduction of the rotor speed by a factor of 3.7 comes from the requirement to keep the energy in the ring constant and, by this, keep the mechanical forces to the pump casing in the same order as for water ring pumps. So a mechanical re-design of the pump was not needed what has led to a much shorter delivery time and significantly reduced costs. The dependency of the rotor speed at constant ring energy from the density of the working fluid (indicated by ρ') is given by

$$v' = \frac{v}{\sqrt{\frac{\rho'}{\rho}}} \quad (1)$$

For mercury, $\rho'(\text{mercury})/\rho(\text{water})=13.5$. This means that the engine speed must be reduced by a factor of 3.7. For a four pole engine, normally running at 1500 rpm, this corresponds to the rotor speed of 400 rpm.

Normally, liquid ring pumps exhaust both, the working fluid as well as the pumped gas via the exhaust connection into a phase separator where the mercury is separated and recycled back to the pump (Fig. 2). Due to the high density of mercury, it is expected

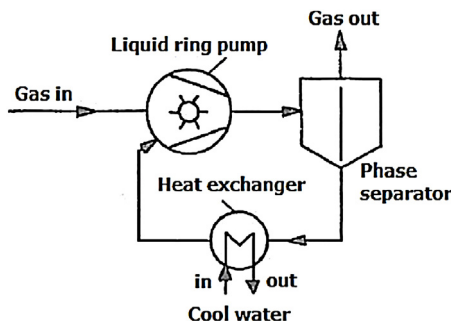

Fig. 2. Flowchart of a liquid ring pump station [5].

that this will not work for mercury exhaust on our ring pump. In consequence, a closed mercury circuit via a heat exchanger (that removes the compression heat) back to the pump would not be possible, leading to pump overheating after a short operational time. Hence, as special design solution for our ring pump, an additional connection on the pump case has been foreseen that removes mercury from the pump at any time and independently from the pump exhaust. This fore-separation connection is connected in parallel to the phase separator.

As third important modification, a new sealing and shaft feedthrough-system has been implemented: the pump rotor is levitated by oil lubricated bearings, separated from the mercury in the pump by a slide ring seal system with pressurized (0.3 MPa) water as sealing fluid. This system does not fulfil tritium compatibility requirements but leads to a very high leak-tightness for our test pump.

3.2. Pump installation in THESEUS

For safety reasons, the test pump has been installed in a vented enclosure in THESEUS. Below the whole experimental arrangement and inside the enclosure, there is a water filled bowl that covers any mercury that might leak out the system immediately with water what avoids the formation of toxic mercury vapour effectively. The pumping system is shown in Fig. 3. It is connected to a dosing dome (directly above the enclosure), in which gas can be dosed in at a known flow rate Q using mass flow controllers. In the dome, the pressure p can be measured over a wide range. More details on the configuration of THESEUS, including its operational limits and the accuracy of the installed devices is given in [6].

The pumping system comprises the ring pump itself with the electrical engine. The inlet is connected to the dosing dome via a DN63 vacuum valve, whereas the outlet is connected to the dosing system via a gas clean-up column (outlet baffle, see also chapter 4.2) where the exhaust gas is cooled to a temperature below 240 K to remove most of the mercury vapour [2]. Two safety valves may open an bypass to the pump in case the exhaust gas cooler is blocked and the pump builds up an outlet pressure of more than 0.05 MPa (e.g. due to freezing of water vapour leaking in the system by the slide ring seals). Fig. 3 shows also the actively cooled 5 L vessels filled with pressurized water for the two slide ring seals (one on each side of the rotor shaft feed-through) and the electrical exhaust gas heater that heats up the cold gas, flowing from the gas clean-up column to the dosing system, to ambient temperature.

3.3. Experimental goals

The major operational characteristic of a vacuum pump is the pumping speed curve as a function of inlet pressure and how it changes for different gas species. Theoretically, there should not be a strong gas species dependency as LRPs are volumetric pumps where the kinetic velocity and the diffusivity of the gas molecules does not play a role.

As already mentioned, the pressure in the THESEUS dosing dome p can be measured at a known flow rate Q . This allows the calculation of the pumping speed S by

$$S = Q/p \quad (2)$$

If this is done for various flow rates and plotted as function of the inlet (i.e. the dosing dome) pressure, this gives the desired pumping speed curve, valid for a defined gas species and rotor speed.

However, before this kind of measurement has been done, a very simple pump-down test of the 450 L dosing dome has been done to see if the pump works at all with mercury and to gain some operational experience. This simple experiment allows the determination of the ultimate pressure that can be reached with such

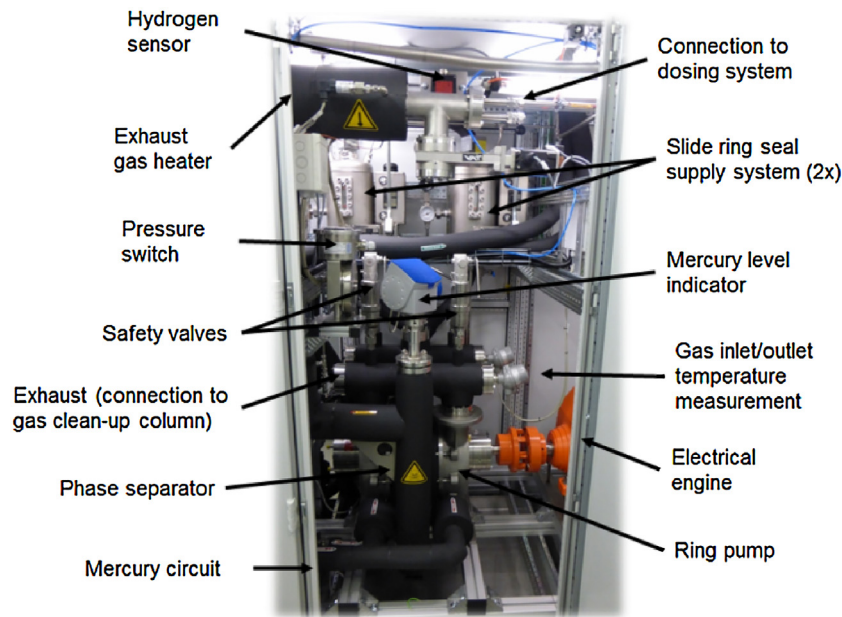

Fig. 3. Pump installed in the enclosure.

a pump and the operational behaviour. Also the average pumping speed can be calculated by

$$S = -\frac{V}{\Delta t} \cdot \ln(\Delta p) \quad (3)$$

where V is the volume of the dosing dome, Δt is the time interval in the course of the pump-down and Δp the pressure difference achieved over the time interval Δt .

The ultimate pressure is of high interest as this pump must work at untypically low inlet pressures to meet the foreline requirements for the primary pumps. LRP's are normally operated at rough vacuum (some 10 or even 100 hPa) and they cannot achieve much lower pressures due to the vapour pressure of the working fluid: When changing from e.g. water (23'400 Pa at 293 K) towards mercury (0.163 Pa at 293 K), correspondingly lower ultimate pressures are to be expected, but where the technical limit is (most probably above 0.163 Pa), is unknown and must be shown by experiments.

3.4. Results

During the first pump-down test, the pump was filled with mercury to the centre of the shaft and started slowly using the variable speed drive (VSD). Within 32 s, the electric gear engine reached its nominal speed of 1500 rpm, corresponding to a pump rotor speed of 412 rpm (due to the gearbox transmission). The run-up worked without problems and the power consumption did not exceed 4.3 kW (engine rated to 7.5 kW). Before starting the experiment, it has to be ensured that the exhaust gas cooler for mercury removal is cold (temperature below 240 K) and that inlet (to dosing dome) and outlet (outside building) valves are open. The pressure drop in the dosing dome is shown in Fig. 4. This curve was measured with nitrogen as test gas.

The pressure dropped quickly and stabilized at an ultimate pressure of 6 hPa after some ten seconds. A calculation of the average pumping speed according equation 3 shows an average pumping speed of 98.8 m³/h. When decreasing the pump outlet pressure from ambient to approx. 15 hPa (simulating a second pump stage) by connecting the exhaust line to another vacuum pump, the pressure dropped down to 0.65 hPa. During the whole experiment, the pump run very smoothly and without vibrations. This was a

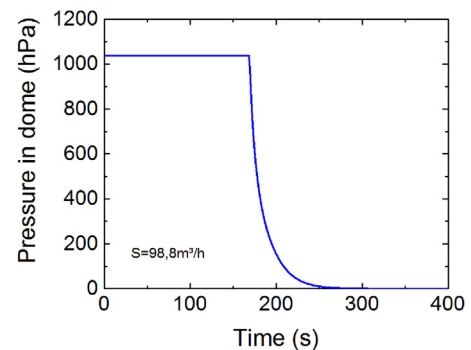

Fig. 4. First pump-down curve.

major outcome of this work as it showed clearly the liquid ring pumps work and that they can reach ultimate pressures required for roughing the diffusion pumps foreseen for DEMO [2].

After this first experimental campaign, there was a break for updates, data analyses and a change in the piping of the mercury circuit (see chapter 4.2) of approx. 18 months. Afterwards, in 2015, a second campaign was started which focused on the measurement of different pumping speed curves (pumping speed as function of the inlet pressure). Fig. 5 shows the curves for helium and nitrogen for the compression against atmosphere. In view of maximum pumping speed and achievable ultimate pressure, the pump showed a poor performance compared to the 2013 campaign (see Fig. 6): the inlet pressure in 2013 was approx. one order of magnitude better and the pumping speed was a factor 3–10 better, with no (strong) dependency of pumping speed on inlet pressure.

The pumping speed curves shown in Fig. 5 were measured via the throughput method (eq. (2)) and are, hence, limited by the maximum dosing capability of the THESEUS facility, whereas the measurement shown in Fig. 6 was derived indirectly (eq. (3)) from the pump-down experiment shown in Fig. 4. It must be noted that the high throughput region (at correspondingly high pressures) is not of prime interest for us.

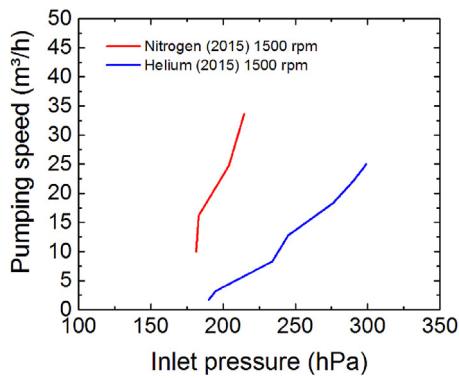

Fig. 5. Pumping speed curves for nitrogen and helium.

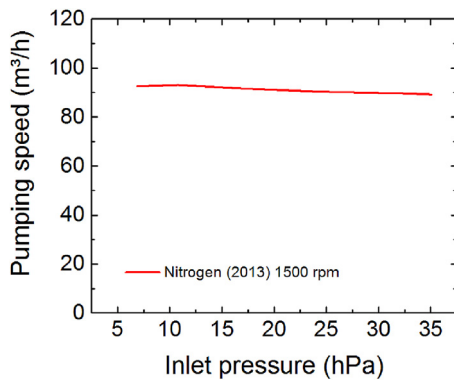

Fig. 6. Pumping speed curves for the first pump-down.

4. Lessons learned

4.1. Pump design and operation

After a discussion with the manufacturer about the unexpected performance results in the 2015 campaign, the following two potential reasons have been identified: Firstly, the slide ring seals consume during normal operation a certain amount of water. This is normal but for vacuum systems, this is not acceptable. During our experiments, it is thus very likely that water contaminated the system what made it impossible to reach the original ultimate pressure and performance. For future pumps, we have decided to change from the slide ring seal concept with outer (standard) bearings towards a solution that applies dry ceramic bearings that can run in mercury. The coupling to the electric drive could then be done by magnetic coupling, what makes the pump hermetically tight, especially when combining with all-metal seals that are perfectly mercury (and tritium) compatible.

Secondly, LRPs use internal control discs [5] that allows the pump to operate at optimized pumping speeds over the whole inlet pressure range. Optimized means that the suction chamber volume, controlled by flutter valves in the disc, varies with the required compression ratio and thus avoids over-compression (if the chamber volume is smaller than necessary (smaller pumping speed), the outlet pressure is higher than needed). During operation with the high density mercury, the flutter valves may break. The effect would be that the chamber volume cannot be controlled anymore and the pump works more as a blower (kinetic pump) than as a volumetric pump, with the consequence that a clear gas species dependency and a much lower pumping speed can be found. This can be avoided by omitting valves inside the pump. The consequence of this change would be that the pump is then limited to one operational point (compression ratio and throughput). This means,

if the pump is optimized e.g. to high compression ratios, it will not be able anymore to reach high throughputs. However, as the main goal for our applications is the operation at limited throughput but at high compression, this optimization is not a problem and must be implemented in future.

In view of operational aspects it could be demonstrated that the pump works very smoothly and without vibrations as long as the rotor speed is above 135 rpm (corresponding to 500 rpm engine speed). This value is valid at a maximum compression ratio; with lower compression ratios, the rotor speed can even be reduced more (as the ring is more stable) leading to a lower energy consumption. Ramp-up and ramp-down of the pump should be done slowly because when the ring collapses and its energy is dissipated, high mechanical forces act on the pump casing. VSD operation with a ramp-up/down speed of the engine of 500 rpm/min have been found to be ideal. Concerning cooling, a minimum differential pressure between pump inlet and outlet of 250 hPa should not be underrun, otherwise the flow in the mercury circuit (through the heat exchanger) cannot be driven anymore and the pump temperature will raise until it overheats. When using a two-stage system with two pumps connected in series (planned for DEMO [2]), this means that only the first stage (i.e. towards atmosphere) can rely on cooling via a heat exchanger in the mercury circuit; the second stage needs a dedicated jacket for cooling.

The experience described above has already been incorporated in the design of a fully tritium compatible pumping system in DEMO relevant scale that has been developed for tritium processing in JET (Mechanical Tritium Pumping System (MTPS), design description see Ref. [7]) and will be tested during the next tritium experiment.

4.2. Mercury handling and removal

After some hours of pump operation, a problem in the piping of the mercury circuit has been detected. This has led to a slow but constant temperature raise in the system as the mercury flow through the heat exchanger was insufficient. To solve this problem, a part of the piping had to be renewed. For this work, it was necessary to drain the mercury, do the required change, and refill the system again. Therefore, the following procedure has been established: Firstly, most of the mercury in the pump has been drained into a 20 L storage vessel located below the pump and connected by 8 mm plastic hoses. Important hereby is that an equipotential bonding connection (to avoid the risk of an electric shock due to electrostatic charging) and a venting hose from the storage vessel to a venting system has to be foreseen. Afterwards, the flanges/piping can be opened using respiratory protection and extensive venting. Below the flanges, a water filled bowl has to be placed to cover effluent mercury droplets immediately with water and thus prevent the formation of vapours, following the same approach as for the water-filled bowl in the enclosure. The openings to mercury containing components (pump, pipes) must be sealed as soon as possible with an airtight tape. The mercury covered with water is transferred to a vessel that allows phase separation. Therefore, a special handling tool has been developed and manufactured at KIT. This device uses vacuum for pumping the water/mercury mixture. The vacuum (~ 300 hPa) is generated by a ejector pump operated with pressurized air (~ 0.6 MPa). As the exhaust of the ejector pump might contain mercury (because the pressurized air mixes with the air/vapour coming from the separator vessel) it is guided by a hose directly to the venting system (flowchart of the device see Fig. 7). Liquid mercury drained from the handling device is guided to the 20 L storage vessel by gravity forces. For filling the mercury back in the system, the storage vessel is placed above the pumping system (using a crane as the weight is approx. 400 kg) and connected to the pump as described above and filled thanks to gravity.

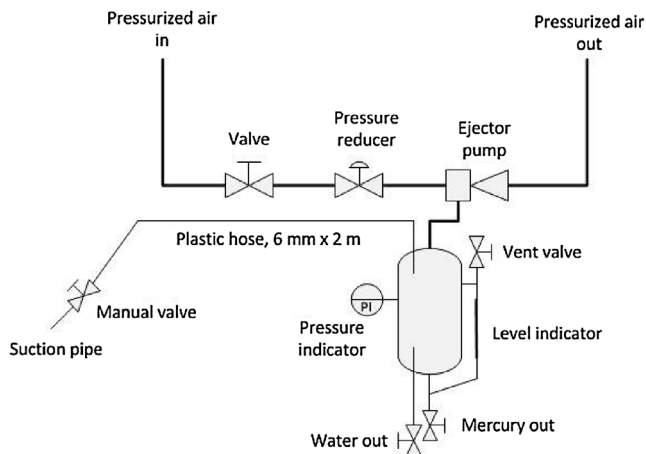

Fig. 7. Flowchart of the handling tool for mercury transfer.

In LRPs, there is an extensive contact between working fluid and the pumped gas. To remove the mercury vapour, a cold trap downstream the pump has been foreseen. In THESEUS, it comprises a 160 mm diameter pipe (height approx. 900 mm) filled with packing (by Raschig, SuperRing® 0.1) and cooled with liquid nitrogen by internal cooling coils. It has been found that this system works only to a flow rate of 7.2 m³/h (stp), afterwards the cooling capacity is not sufficient anymore. Another weak point of this system is that it seems that gas can bypass the cooling zone of the gas cooler leading to a mercury signal in the atom adsorption spectrometer that monitors the emission. Though working good enough for our experiments, it has become clear that this solution will not be an option for future (more industrial) systems and a new outlet baffle must thus be developed. A new baffle, based on the experience with this system, has been designed and already implement in MTPS. It is based on a plate heat exchanger and described in more detail in [7].

5. Outlook & conclusion

During two experimental campaigns and more than 60 h of pump operation, it could be shown clearly that liquid ring pumps

with mercury as working fluid are a viable solution. The proof-of-principle experiments were successful and much valuable operational experience could be gained. All experience generated by this activity was fed directly in the design of a more advanced and fully tritium compatible system that will in a next step be tested during the next tritium campaign at JET, already in DEMO relevant scale and under fusion relevant conditions.

Acknowledgments

This work has been carried out within the framework of the EUROfusion Consortium under the Work Package TFV (Tritium, Matter Injection and Vacuum) and has received funding from the Euratom research and training programme 2014–2018 under grant agreement No 633053. The views and opinions expressed herein do not necessarily reflect those of the European Commission.

The authors would like to thank the whole THESEUS team who made the experiments possible as well as the company Hermetic for their support in this project.

References

- [1] R.J.H. Pearce, et al., Gas species, their evolution and segregation through the ITER vacuum systems, *Vacuum* 86 (2012) 1725–1730.
- [2] T. Giegerich, C. Day, The KALPUREX-Process – a new vacuum pumping process for exhaust gases in fusion power plants, *Fus. Eng. Des.* 89 (7–8) (2014) 1476–1481.
- [3] T. Giegerich, C. Day, Conceptuation of a continuously working vacuum pump train for fusion power plants, *Fus. Eng. Des.* 88 (2013) 2206–2209.
- [4] W. Gaede, Die Diffusion der Gase durch Quecksilberdampf bei niederen drücken und die Diffusionsluftpumpe, *Ann. Phys.* 46 (1915) 357–393.
- [5] H. Bannwarth, Flüssigkeitsring-Vakuumpumpen, –Kompressoren und –Anlagen Konventionell und Hermetisch, 1st edition, Wiley-VCH, Weinheim, 1994.
- [6] C. Day, T. Giegerich, Development of advanced exhaust pumping technology for a DT fusion power plant, *IEEE Trans. Plasma Sci.* 42 (2014) 1058–1071.
- [7] T. Giegerich, et al., Advanced design of the mechanical tritium pumping system for JET DTE2, *Fus. Eng. Des.* 109–111 (2016) 359–364.