

OPTIMAL RENEWABLE ENERGY BASED SUPPLY SYSTEMS FOR SELF-SUFFICIENT RESIDENTIAL BUILDINGS

M. Kleinebrahm¹, J. Weinand¹, A. Ardone¹ and R. McKenna¹

¹ Karlsruhe Institute of Technology (KIT), Institute for Industrial Production (IIP), Chair of Energy Economics, Karlsruhe, Germany

ABSTRACT

To cover 100% of the energy demand using renewable energies, technologies like small wind turbines (SWT) or hydrogen (H₂) storage systems could be integrated into the household energy system. In this study optimal self-sufficient energy supply systems for residential buildings are determined using an MILP optimization model. To consume energy at the time it is generated, flexible devices and optimal charging strategies for electric vehicles are considered. Least cost systems for different regions are identified and compared to a conventional reference system. It is shown that H₂ storage systems and SWT can be economically beneficial for self-sufficient household supply.

INTRODUCTION

The household and transport sectors accounted for over 55% of final energy consumption in Germany in 2016 (Umweltbundesamt). Due to the steady decline in the price of photovoltaic (PV) systems, the levelized cost of electricity of rooftop PV is lower than the electricity price for private households in Germany since about 2010 (Karneyeva and Wüstenhagen, 2017). In order to increase the share of self-consumption, over 80,000 PV systems in Germany were installed with a battery storage (BS) by the beginning of 2018 (BSW Solar, 2018). With a further drop in prices and a resulting large-scale expansion of on-site supply systems, less electricity could be drawn from the grid and the fixed portion of the electricity retail price must be allocated over less electricity. This development could lead to increasing electricity prices or to the introduction of new tariff schemes (Agnew and Dargusch, 2015; Janko et al., 2016; Parag and Sovacool, 2016). PV-BS systems need to be extremely oversized for residential off-grid supply in

Germany due to the seasonal character of PV generation and the high specific cost of battery storage (Bracke et al., 2016). To provide energy when the sun is not shining, technologies like small wind turbines or hydrogen storage systems need to be taken into account. Additionally, flexibility options on the demand side can be used to match household demand and supply. Hence, in the longer term, it is important to evaluate how many additional costs have to be spent to become independent from rising electricity prices and fossil fuels.

Self-sufficient renewable energy based household supply systems have been studied by several researchers. Kotzur et al. (2017) calculate cost-optimal energy supply systems for a self-sufficient single family household (SFH), focussing on different H₂ storage options. By using a reversible SOFC combined with a Liquid Organic Hydrogen Carrier (LOHC) system for long-term storage, energy cost can be reduced by 72% compared to a PV-BS based system. Leonard and Michaelides (2018) investigate two grid independent zero-energy buildings (ZEB) in the USA, which are supplied by PV-BS-H₂ Systems. Energy conservation and efficiency measures are identified to have the greatest impact on PV area and nominal power requirements. Lacko et al. (2014) evaluate the feasibility of a completely renewable based heat and electricity supply for an isolated household in Slovenia's costal region using the simulation software HOMER and actual measured data. The results show that 100% renewable energy supply is technically feasible and can be cost-effective compared to a fossil fuel based energy supply system. Marino et al. (2013) analyse an energy supply system for a public building, combining a small wind turbine with PV modules and a H₂ storage system, with regard to economic and

ecological criteria. The system is dimensioned for off-grid operation but can only be operated economically when connected to the grid. Goldsworthy and Sethuvenkatraman (2018) show that electrical self-sufficiency with a PV-BS system can be economical in Australia if demand side adjustments are made. In pilot projects, self-sufficient residential buildings with SWT and H₂ storage facilities are already being built. Prominent examples are the world's first energy self-sufficient multi-family house, the "Oekohaus Markert", in Switzerland, and the "Solar House" in Germany (Diermann, 2016; Schleicher, 2014; Voss et al., 1995). Table 1 gives an overview of the presented sources and projects. An integrated analysis of load flexibilities by electric vehicles and household appliances in combination with innovative small scale technologies such as H₂ storage and SWT for 100% self-sufficient residential buildings is missing in literature. By taking into account flexibility potentials, storage demand and generation plants could be reduced resulting in lower system costs. In this paper a mixed integer linear programming (MILP) optimization model is presented which determines the optimal system structure and dispatch of self-sufficient energy supply systems, taking into account flexible devices on the demand side as well as optimal charging strategies for electric vehicles (EV). Different self-sufficient energy supply systems are compared and effects of different local conditions are investigated. Furthermore, cost developments are examined depending on the degree of self-sufficiency (DSS).

METHODOLOGY AND DATA

Model overview

Only an integrated analysis can account for the interactions between generation, conversion, storage and demand side flexibilities in order to find the optimal energy supply system structure for self-sufficient buildings. To determine the optimal design and operation of the energy supply system, a MILP model is developed, which minimizes total system cost over a period of 20 years using a Greenfield approach. Therefore, energy and mass flows are calculated in hourly resolution for a period of one year. An overview of the technologies and their interconnections considered in this paper can be found in Figure 1. Solar thermal (ST) energy is not taken into account due to the competition for roof area with PV. The presented model is generated in Matlab and solved with the Gurobi solver.

Target function

The target function (cf. Eq. (1)) minimizes the objective value (OBJ) as total discounted system cost (TDSC) over a period of consideration (*poc*=20 years) (Variables are printed in bold below).

$$\min \mathbf{OBJ} = \sum_{l \in L} c_{l,inv} + \sum_{a=1}^{poc=20} \frac{\mathbf{acf}}{(1+i)^a} \quad (1)$$

Table 1: Overview of discussed papers and projects regarding renewable based self-sufficient energy supply for single buildings (PV: photovoltaic, SWT: small wind turbine, BS: battery storage, H₂: hydrogen storage system, DSM: demand side management, EV: electric vehicle, HS: heat storage, HP: heat pump, ST: solar thermal plant, HR: heating rod)

Source	Application/Description	Approach	Technology								Country		
			PV	SWT	BS	H ₂	DSM	EV	HS	HP		ST	HR
Kotzur et al. 2017	100% renewable based energy supply for SFH	Cost-optimisation	x		x	x			x	x		x	Germany
Leonard et al. 2018	Analysis of two off-grid ZEB	Simulation	x			x	x						USA
Lacko et al. 2014	Hybrid energy system for heat and power supply	Homer Simulation	x	x		x			x			x	Slovenia
Marino et al. 2013	Electrolysis to generate hydrogen in a public building	Environmental and economic analysis	x	x		x							Italy
Goldsworthy et al. 2018	28 off-grid households	Simulation	x		x		x						Australia
Projects	First self-sufficient MFH	-	x		x	x	x		x	x			Switzerland
	Self-sufficient energy house Markert	-	x	x	x						x		Switzerland
	Solarhouse Freiburg	-	x		x	x			x		x		Germany
This study	Optimal energy supply system for SFH	Cost-optimisation	x	x	x	x	x	x	x	x		x	Germany

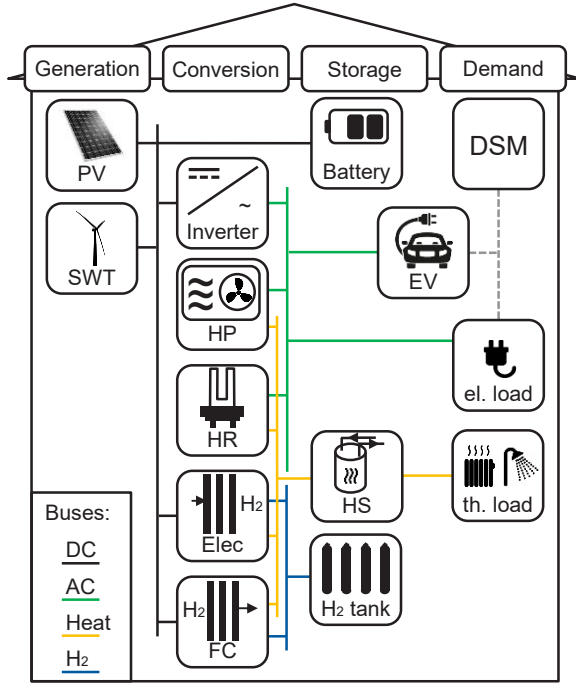

Figure 1: Household energy supply system (Elec: electrolysis, FC: fuel cell, el.: electrical, th.: thermal)

The objective value is the sum of the investments ($l, j \in L$) in the individual technologies ($c_{l,inv}$) and the discounted sum of annual cash flows (acf). The technology investment consists of three parts: the investment itself, the reinvestment and the remaining value after the period of consideration (cf. Eq. (2)). The product of the technology specific investment cost in year a ($c_{l,inv,spc,a}$) and the installed capacity (cap_l) is considered as the investment itself. If the period of consideration exceeds the calendar lifetime of technology l , a reinvestment is taken into account. If the calendar lifetime (clt) exceeds the period of consideration, the residual value of the technology is subtracted based on the remaining calendar lifetime (clt_{rem}).

$$c_{l,inv} = c_{l,inv,spc,a=0} \cdot cap_l + \frac{c_{l,inv,spc,a=clt_l} \cdot cap_l}{(1+i)^{clt_l}} - \frac{clt_{rem,l}}{clt_l} \left(\frac{c_{l,inv,spc,a=poc} \cdot cap_l}{(1+i)^{poc}} \right) \quad (2)$$

The acf consists of capacity specific fixed operation and maintenance cost ($c_{l,O\&M}$) and the sum of flow specific ($f_{l,j,t}$) variable cost ($c_{l,j,var}$) per time step (t) over the period of one year (T).

$$acf = \sum_{l \in L} c_{l,O\&M} \cdot cap_l + \sum_{l \in L} \sum_{j \in L} \sum_{t \in T} c_{l,j,var} \cdot f_{l,j,t} \quad (3)$$

Analogous to Kaschub et al. (2016), neither the investment decision in an EV nor the costs of the EV are considered in the model. It is assumed that the investment in the EV is only made for reasons of mobility.

Main constraints

The properties of the technologies, their interactions and the household demand, described in Figure 1, are mathematically represented in the model using five different classes: generator, consumer, converter, storage and buses. The mathematical formulation of the classes is generically described in Eq. (4)-(8), analogous to Kotzur et al. (2017).

$$cap_l \cdot p_{l,t} = \sum_{j \in L} f_{l,j,t} \quad \forall l, t \quad (4)$$

$$\sum_{l \in L} f_{l,j,t} = d_{j,t} \quad \forall j, t \quad (5)$$

$$\sum_{l \in L} f_{l,j,t} \cdot \eta_{j,t,con} = \sum_{k \in L} f_{j,k,t} \quad \forall j, t \quad (6)$$

$$\eta_{j,ch} \cdot \sum_{l \in L} f_{l,j,t} - \eta_{j,dch} \cdot \sum_{k \in L} f_{j,k,t} + SOC_{j,t-1} \cdot (1 - \eta_{j,sd}) = SOC_{j,t} \quad \forall j, t \quad (7)$$

$$\sum_{l \in L} f_{l,j,t} = \sum_{k \in L} f_{j,k,t} \quad \forall j, t \quad (8)$$

p_l : technology specific normalized output

d_l : load specific household demand

η_{con} : conversion efficiency

η_{ch} : charging efficiency

η_{dch} : discharging efficiency

η_{sd} : self discharge rate

SOC : State of charge

Generation

To calculate the amount of electricity that is generated by PV modules and SWT for different geographical locations, the local amount of irradiance and the wind speed are simulated. The calculation of the global irradiance on tilted PV modules is done according to the presented approach in (Mainzer et al., 2017). Based on the calculated position of the sun and radiation data (provided by DWD (2011)), the components of direct, diffuse and reflected radiation are determined. The calculation of the normalized electrical PV output is based on the global irradiance, the module temperature and technical properties of the PV module (Quaschnig, 2015).

A south orientation with a roof tilt of 34° and a 300 Watt module (Percium JAM6) are assumed for performance modelling. To estimate the local wind speed at different altitudes, reanalysis data from Modern Era Retrospective Analysis (MERRA) are used (Steven Pawson, 2015). The data are in a temporal resolution of one hour, a spatial resolution of 50km, are available worldwide and are given at 10m above displacement height. Due to the relatively low spatial resolution, local effects are not captured properly. However, since the focus of this study is not on the assessment of the operation of SWT at certain locations, but rather on the general investigation of areas in which self-sufficient buildings might be applied, the wind data are sufficient. For the wind speed estimation at other heights than 10m, the power law is used (Quaschnig, 2015):

$$v(h_2) = v(h_1) \cdot \frac{\ln((h_2 - d)/z_0)}{\ln((h_1 - d)/z_0)} \quad (9)$$

h_1 : Measurement height (10m)

h_2 : Turbine height (m)

d : Displacement height (m)

z_0 : roughness (m)

The normalized turbine output is calculated using the local wind speed at turbine height (12 m) and an averaged normalized power curve. The averaged power curve is based on all SWT certified by the Small Wind Certification Council (2018) within a rated power of 1 to 6 kW. Ten percent losses due to dirt on blades, maintenance, forced outages etc. are considered (Olauson et al., 2016). A roughness length of 0.03 m and a displacement height of 0 m are assumed for the calculations, which corresponds to a remote landscape with some houses (Quaschnig, 2015).

Conversion

To convert a mass/energy flow into another mass/energy flow, five conversion technologies are integrated in the model. The inverter converts DC into AC with a power-independent efficiency. The heating rod and the air-source heat pump convert AC into heat. The heating rod has a constant conversion efficiency, while the conversion efficiency of the heat pump (COP) is dependent on the temperature difference between heat source and heat sink and is

therefore calculated for each time step (Staffell et al., 2012). To convert DC electricity into H₂ a proton exchange membrane (PEM) electrolysis cell is used due to the good combinability with renewable energy sources. The operating temperature of 80°C enables a quick start-up and the operation at partial loads. The same advantages apply to the reconversion in a PEM fuel cell (Teichmann et al., 2012). The by-product of electrolysis and fuel cell operation is waste heat, which can be used for domestic hot water and room heating. The employed conversion efficiencies are shown in Table 2.

Storage

Energy can be stored in the form of electricity, heat and H₂. All storages are modelled with a charging and discharging efficiency and a self-discharging rate according to Eq. (7). Electricity can be stored in the stationary DC-coupled Lithium-Ion BS and in the AC-coupled EV BS. Due to charging with constant current and voltage, the charging power of the Batteries is reduced for a high state of charge (SOC) according to Kaschub et al. (2016). It is possible to feed electricity from the EV BS back into the house grid. The discharging of the EV causes additional BS aging, which is taken into account with a price of 6.75 ct/kWh (based on a BS investment of 270 €/kWh and 4000 equivalent full cycles). The EV SOC is limited by a lower and upper bound and the EV can only be charged at home (Figure 2).

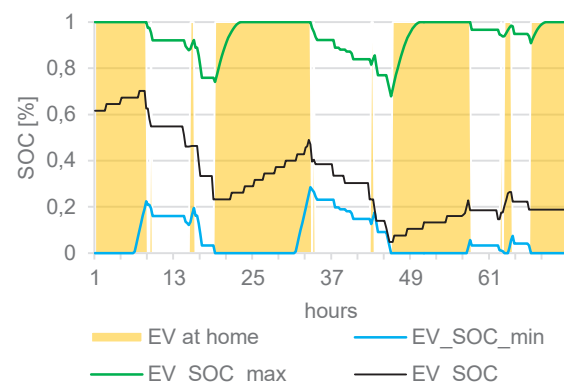

Figure 2: Exemplary course of the EV SOC for three days based on (Kaschub et al., 2016)

Mobility patterns of households are used, which are modelled in Kaschub et al. (2016) based on survey data for conventional vehicles (BMVBS, 2010). In this study a BS EV with a BS size of 28 kWh is considered. The produced heat is stored

in a hot water storage from which the demand for domestic hot water and space heating is covered. H₂ can be stored in a H₂ tank at a pressure of 200 bar. As in (Kotzur et al., 2017), an isentropic compressor efficiency of 75% is assumed, so that three kWh of electrical energy is required to compress one kg of H₂. Three kWh electricity corresponds to approx. 10% of the calorific value of one kg H₂. Consequently, taking into account $\eta_{elec,el.}$, a H₂ tank charging efficiency of 93% is assumed. An overview of the assumed charging and conversion efficiencies is given in Table 2.

Table 2 Charging and conversion efficiencies

Technology	Parameter	Efficiency [%]
BS	$\eta_{ch}/\eta_{ach}/\eta_{sd}$	95/95/0.003
EV	η_{ch}/η_{ach}	90/90
HS	$\eta_{ch}/\eta_{ach}/\eta_{sd}$	95/95/0.83
H ₂ tank	η_{ch}/η_{ach}	93/100
Inverter	$\eta_{inverter}$	95
Heating rod	η_{HR}	98
Electrolysis	$\eta_{Elec,H2}/\eta_{Elec,th.}$	70/20
Fuel Cell	$\eta_{FC,el.}/\eta_{FC,th.}$	55/35

Demand

The thermal and electrical household demand must be covered in every time step of the year in accordance to Eq. 5. The employed synthetic load profiles are generated with the software SynPro (Fischer et al., 2016). Electrical load profiles are available in device-specific resolution and heat demand is composed of hot water consumption and space heating. The charging profiles for the EV are taken from Kaschub et al. (2016). A single-family household (passive-house standard) with two inhabitants and an annual electrical demand of 5349 kWh (household devices: 2905 kWh, EV: 2444 kWh) and a thermal load of 5663 kWh/a (space heating: 3328 kWh/a, domestic hot water: 2335 kWh/a) is examined. In order to take load flexibility on the demand side into account, it is assumed that the washing machine, dishwasher and dryer can be operated flexibly within 24 hours after their original switch-on. The load flexibilities are considered in the model using equations (10)-(12).

$$d_{el,t} = d_{base,t} + \sum_{fl} d_{fl,t} \quad (10)$$

$$s_{fl,org,t} = s_{fl,t} \cdot s_{fl,pos,t} \quad (11)$$

$$d_{fl,t_2} = s_{fl,t_1} \cdot d_{fl,t_1,t_2} \quad (12)$$

$$\forall t, t_1, t_2 \in T, \forall fl \in FL$$

d_{el} : electrical demand

d_{base} : electrical base demand

d_{fl} : demand of fl

$s_{fl,org}$: original start of fl (binary parameter)

$s_{fl,pos}$: possible start of fl (binary parameter)

s_{fl} : start of flexible load (binary variable)

d_{fl,t_1,t_2} : demand of fl in t_2 when started in t_1

RESULTS AND DISCUSSION

Optimal energy supply systems to cover the energy demand for electricity, heat and mobility are calculated for a passive house in Brunswick (town in the middle of Germany). To investigate the effects of different meteorological conditions on the sizing of the energy supply system in Germany, single family houses in the surroundings of Brunswick, Munich and Buesum are compared. The economic assumptions are shown in **Fehler! Verweisquelle konnte nicht gefunden werden.**. The economic parameters for the H₂ system are subject to high uncertainty, as the H₂ system is a combination of future technologies for which no market data are yet available. A nominal interest rate of 4% is assumed.

Table 3: Cost assumptions according to (Grieser et al., 2015; Kaschub et al., 2016; Kotzur et al., 2017)

Technology	Investment [€/kW(h)]	O&M [%/Inv./a]	Lifetime [a]
PV	1350	1.5	25
SWT	6000	2.5	20
Inverter	250	-	15
Heat pump	1150	2	20
Heating rod	100	2	30
Electrolyser	5550	2	10
Fuel cell	4530	2	10
H ₂ -tank	25	-	25
Heat storage	45	-	25
BS	600	-	15

Self-sufficient energy supply systems

Figure 3 gives an overview of the TDSC of six different technology combinations suitable for self-sufficient renewable energy based supply of a passive house in Brunswick. In addition, the TDSC of a reference system [ref] are shown in which electricity is drawn from the grid. An electricity price of 29.81 cent/kWh and an electricity price increase of 2 %/a are assumed. A HP/HS combination is used to cover the thermal demand. 7887 kWh/a are drawn from the grid to cover the household energy demand for electricity, heating and mobility. The base system (Base) consists of the following technologies: PV,

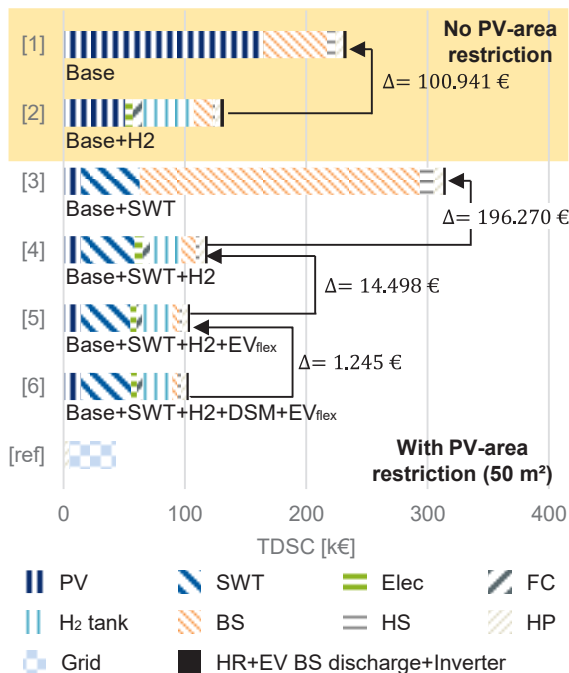

Figure 3: TDSC of energy supply system configurations

BS, HS, HP, HR and Inverter. In system configuration [1] the optimal supply system is determined only under consideration of base system technologies. Due to the fact that the PV system is the only source of power, a self-sufficient supply is not possible if an area restriction of 50 m² is taken into account, which corresponds to a PV peak power of 9.17 kWp. Without taking the area restriction into account, self-sufficient energy supply can be realized by system configuration [1] with TDSC of 233 k€. Over 93 % of the TDSC are caused by the installation and operation of the PV system (105 kWp ~ 71 %) and the BS (62 kWh ~ 22 %). By extending the base system with an H₂ storage system [2], the TDSC can be reduced by 43%. A self-sufficient operation is still not possible under consideration of the PV-area restriction. If the basic system is extended by a SWT [3], an additional electricity source is available and a self-sufficient household supply can be achieved while complying with the PV-area restriction. To provide electricity in periods of low solar irradiation and wind speed, a BS with a capacity of 273 kWh is installed, which accounts for over 73 % of the TDSC. In System [4] a SWT and a H₂ storage system are installed together. The BS (14 kWh) is only used for diurnal storage while the H₂ storage system (1232 kWh) is used for long-term storage. In addition to [4], the EV is charged flexibly and electricity stored in the EV BS can be fed back into the household grid (EV_{flex}) in [5]. The

EV BS (28 kWh) partially replaces the BS in [5], which has a capacity of only 7 kWh. The cost optimal system configuration [6] is composed of all technologies described in Figure 1. In addition to [5] load shifting of flexible electric devices is possible (DSM). By taking DSM measures into account, the TDSC can be further reduced by 1.2 %. For diurnal storage a BS is used with a capacity of 5.6 kWh, which is operated with 267 full charge cycles (stored energy/capacity) per year in system [6]. To account for the mismatch between generation and demand in summer and winter, the H₂ system is used as a seasonal storage with a H₂ tank capacity of 1,145 kWh, which is operated with 1.27 full charge cycles per year. The TDSC of system [6] are 103 k€ and are therefore more than twice as high as the TDSC of the reference system. It is interesting to analyse how the TDSC behave in relation to the degree of self-sufficiency (DSS = grid supply / grid supply in [ref]) (McKenna et al., 2017). Figure 4 shows that a maximum DSS of 70% can be achieved with a limited PV area, if no SWT is taken into account, without the TDSC being doubled in relation to [ref]. With no PV area restriction, the TDSC of [1] and [2] increase slowly up to a DSS of 80%. To meet the last 20% of the energy demand, the BS in [1] needs to be extremely oversized, which results in high TDSC, while in [2] the H₂ system is used for long-term storage, causing lower TDSC. In addition to the TDSC, Figure 4 shows which technologies are added to system [5] in order to reach certain DSS. The SWT and the H₂ system are only installed, if a DSS of higher than 60% should be achieved.

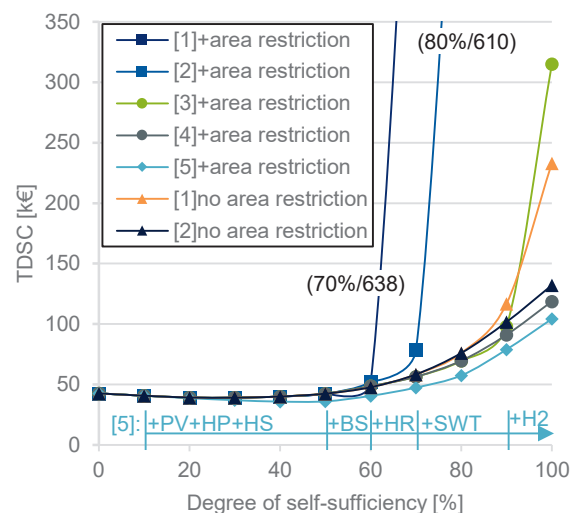

Figure 4: TDSC in dependence of the DSS

Energy supply systems for different locations

To investigate the meteorological influences of different locations on the dimensioning of energy self-sufficient building supply systems, optimal technology combinations for Brunswick, Buesum (at the North Sea) and Munich are calculated. For this purpose, all degrees of freedom are given to the optimizer analogous to System [6]. Due to locally-changing temperatures, solar irradiation and wind speeds, different electricity generation profiles for PV and SWT are calculated, as can be seen in Table 4. Furthermore the locally different space heating loads (SH) are given.

Table 4: Site specific conditions (Temp.: average yearly temperature)

City	PV [kWh/a/kW]	SWT [kWh/a/kW]	Temp. [C°]	SH [kWh/a]
Brunswick	864	916	9.52	3,328
Buesum	1034	1654	9.33	3,937
Munich	1063	415	8.25	4,452

Figure 5 illustrates that the TDSC for the same passive house are strongly affected by the site conditions. Due to good wind conditions in Buesum, the same SWT generates four times more electricity in Buesum in comparison to Munich. This allows both the SWT and the storage system to be dimensioned smaller. The TDSC are heavily dependent on the electricity output of the SWT, as it provides more electricity asynchronously to PV in the winter months, when electricity demand is high due to space heating. Yet, even under good wind conditions, the TDSC of self-sufficient supply systems are almost twice as high as those of the reference system.

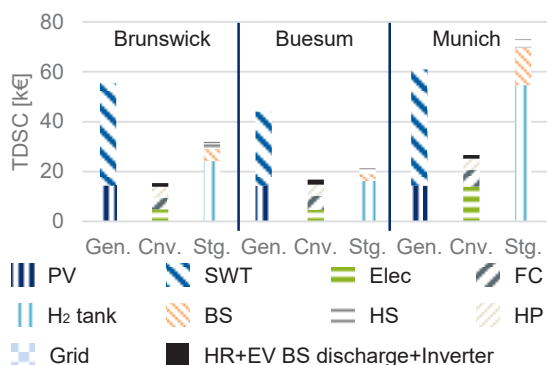

Figure 5: TDSC for different locations (Gen.: Generation, Cnv.: Conversion, Stg.: Storage)

CONCLUSION

In this work the dimensioning and dispatch of self-sufficient renewable energy based supply systems for SFH are determined for different locations. An MILP optimization model is

presented for the calculation of cost-optimal supply systems. Flexible electrical loads on the demand side as well as future technologies like H₂ storage and SWT on the supply side are taken into account. The results indicate that the combination of a SWT and a H₂ storage system with already established technologies is the most economical for self-sufficient energy supply. Load flexibilities on the demand side have a rather small impact on the dimensioning of self-sufficient supply systems. The TDSC of the optimal self-sufficient system are almost twice as high as the TDSC of a conventional supply system. Site conditions have a strong influence on the dimensioning of the energy supply system and therefore on the TDSC. The calculations of this study are based on a multitude of data, some of which are subject to uncertainties; furthermore a deterministic approach is used. Consequently, the results are only a trend and should not be interpreted incoherently. In future work different sites in Europe should be analysed. Bio-fuelled micro combined heat and power plants could be taken into account as a flexible energy source. In addition, aspects of security of supply and the investment in the EV could be analysed.

ACKNOWLEDGEMENTS

This work was supported by the Helmholtz Association under the Joint initiative "Energy Systems Integration".

REFERENCES

- Agnew, S. and Dargusch, P. (2015) 'Effect of residential solar and storage on centralized electricity supply systems', *Nature Climate Change*, vol. 5, no. 4, pp. 315–318.
- BMVBS (2010) Bundesministerium für Verkehr, Bau und Stadtentwicklung; Deutsches Mobilitätspanel (MOP) [Online].
- Bracke, J., Tomaschek, J., Brodecki, L. and Fahl, U. (2016) 'Techno-ökonomische Bewertung von Energie-Autarkie für die Energieversorgung von Einfamilienhäusern', *Zeitschrift für Energiewirtschaft*, vol. 40, no. 3, pp. 127–137.
- BSW Solar (2018) Solarstromspeicher: Nachfrage wächst rasant.
- Diermann, R. (2016) 'Ohne Netz: Erstes völlig energieautarkes Mehrfamilienhaus der Welt fertiggestellt', *Wirtschaftswoche*, 2016.

- DWD (2011) Aktualisierte und erweiterte Testreferenzjahre von Deutschland für mittlere, extreme und zukünftige Witterungsverhältnisse, DWD.
- Fischer, D., Wolf, T., Scherer, J. and Wille-Haussmann, B. (2016) 'A stochastic bottom-up model for space heating and domestic hot water load profiles for German households', *Energy and Buildings*, vol. 124, pp. 120–128.
- Goldsworthy, M. J. and Sethuvenkatraman, S. (2018) 'The off-grid PV-battery powered home revisited; the effects of high efficiency air-conditioning and load shifting', *Solar Energy*.
- Grieser, B., Sunak, Y. and Madlener, R. (2015) 'Economics of small wind turbines in urban settings: An empirical investigation for Germany', *Renewable Energy*, vol. 78, pp. 334–350.
- Janko, S. A., Arnold, M. R. and Johnson, N. G. (2016) 'Implications of high-penetration renewables for ratepayers and utilities in the residential solar photovoltaic (PV) market', *Applied Energy*, vol. 180, pp. 37–51.
- Karneyeva, Y. and Wüstenhagen, R. (2017) 'Solar feed-in tariffs in a post-grid parity world: The role of risk, investor diversity and business models', *Energy Policy*, vol. 106, pp. 445–456.
- Kaschub, T., Jochem, P. and Fichtner, W. (2016) 'Solar energy storage in German households: Profitability, load changes and flexibility', *Energy Policy*, vol. 98, pp. 520–532.
- Kotzur, L., Markewitz, P., Robinius, M. and Stolten, D. (2017) 'Kostenoptimale Versorgungssysteme für ein vollautarkes Einfamilienhaus', in Ramming, K. (ed) *Einleitung; §§ 476 – 480*, Berlin, Boston, De Gruyter, pp. 1–172.
- Lacko, R., Drobnič, B., Mori, M., Sekavčnik, M. and Vidmar, M. (2014) 'Stand-alone renewable combined heat and power system with hydrogen technologies for household application', *Energy*, vol. 77, pp. 164–170.
- Leonard, M. D. and Michaelides, E. E. (2018) 'Grid-independent residential buildings with renewable energy sources', *Energy*, vol. 148, pp. 448–460.
- Mainzer, K., Killinger, S., McKenna, R. and Fichtner, W. (2017) 'Assessment of rooftop photovoltaic potentials at the urban level using publicly available geodata and image recognition techniques', *Solar Energy*, vol. 155, pp. 561–573.
- Marino, C., Nucara, A., Pietrafesa, M. and Pudano, A. (2013) 'An energy self-sufficient public building using integrated renewable sources and hydrogen storage', *Energy*, vol. 57, pp. 95–105.
- McKenna, R., Merkel, E. and Fichtner, W. (2017) 'Energy autonomy in residential buildings: A techno-economic model-based analysis of the scale effects', *Applied Energy*, vol. 189, pp. 800–815.
- Olauson, J., Goude, A. and Bergkvist, M. (2016) 'Wind energy converters and photovoltaics for generation of electricity after natural disasters', *Geografiska Annaler: Series A, Physical Geography*, vol. 97, no. 1, pp. 9–23.
- Parag, Y. and Sovacool, B. K. (2016) 'Electricity market design for the prosumer era', *Nature Energy*, vol. 1, no. 4, p. 16032.
- Quaschnig, V. (2015) *Regenerative Energiesysteme: Technologie ; Berechnung ; Simulation ; mit 119 Tabellen*, 9th edn, München, Hanser.
- Schleicher, V. (2014) 'Passivhaus ganz aktiv', *Energiesparhaus*.
- Small Wind Certification Council (2018) *SWCC Certified Turbines - Small: Compare Ratings* [Online].
- Staffell, I., Brett, D., Brandon, N. and Hawkes, A. (2012) 'A review of domestic heat pumps', *Energy & Environmental Science*, vol. 5, no. 11, p. 9291.
- Steven Pawson (2015) *MERRA-2*,
- Teichmann, D., Stark, K., Müller, K., Zöttl, G., Wasserscheid, P. and Arlt, W. (2012) 'Energy storage in residential and commercial buildings via Liquid Organic Hydrogen Carriers (LOHC)', *Energy & Environmental Science*, vol. 5, no. 10, p. 9044.
- Umweltbundesamt Arbeitsgemeinschaft Energiebilanzen: *Auswertungstabellen zur Energiebilanz der Bundesrepublik Deutschland 1990 bis 2016*.
- Voss, K., Goetzberger, A. and Bopp, G. (1995) 'The Self-Sufficient Solar House Freiburg - Results of Three Years of Operation