

Cascaded H-Bridge based Parallel Hybrid Converter - A novel Topology for perfectly sinusoidal high power Voltage Sources

Lukas Stefanski, Daniel Bernet, Mathias Schnarrenberger, Christoph Rollbühler, Andreas Liske, Marc Hiller

Institute of Electrical Engineering (ETI)
Power Electronic Systems

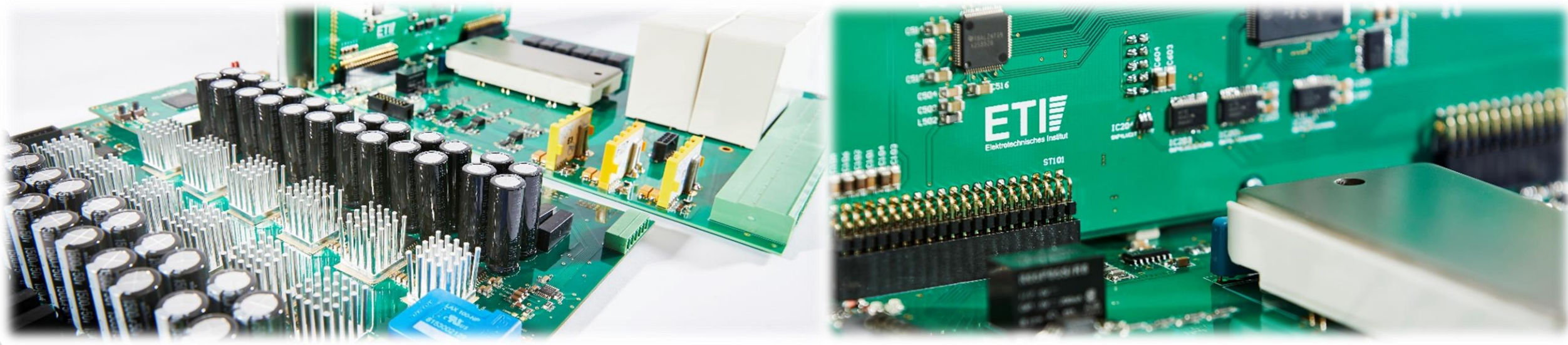

Cascaded H-Bridge based Parallel Hybrid Converter

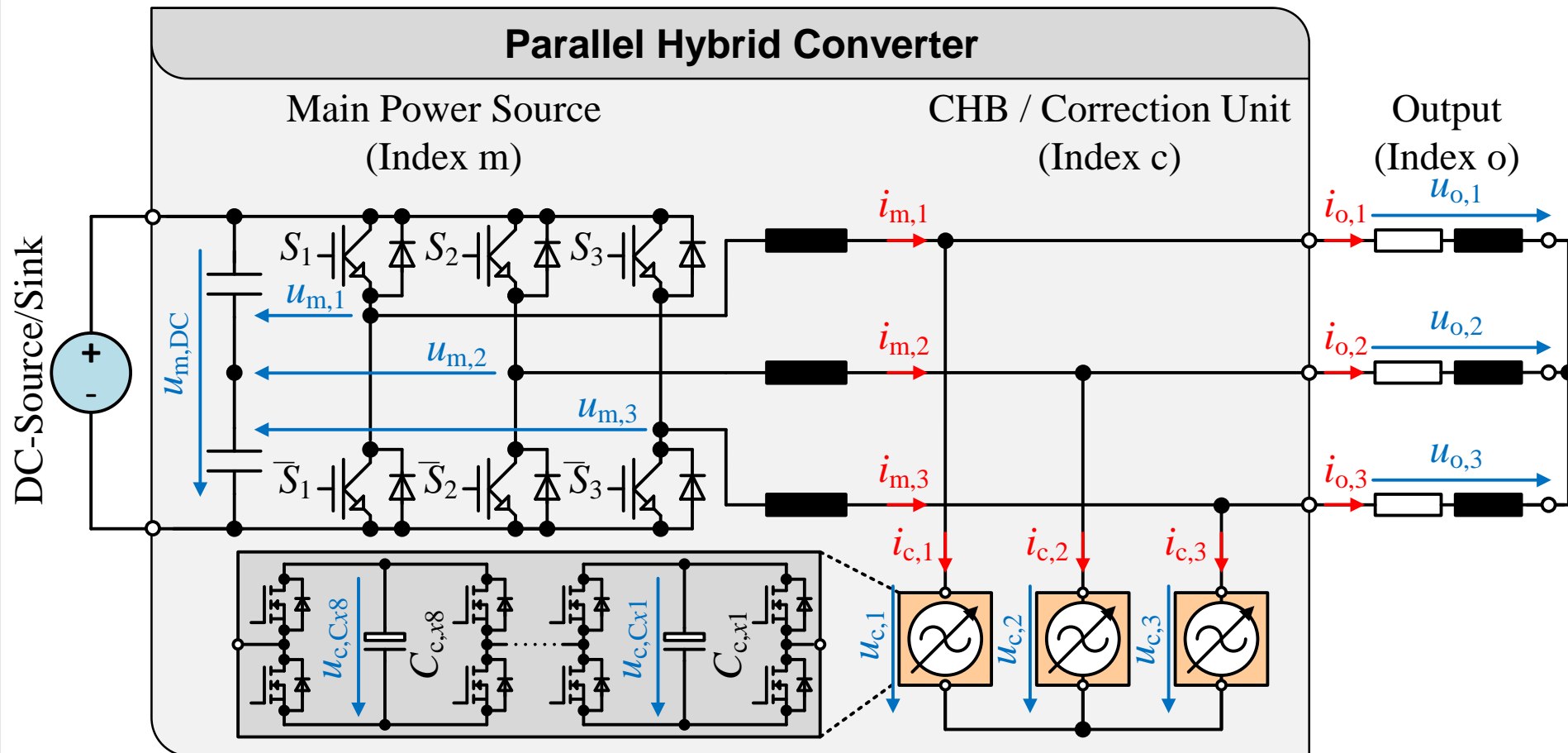

Cascaded H-Bridge based Parallel Hybrid Converter

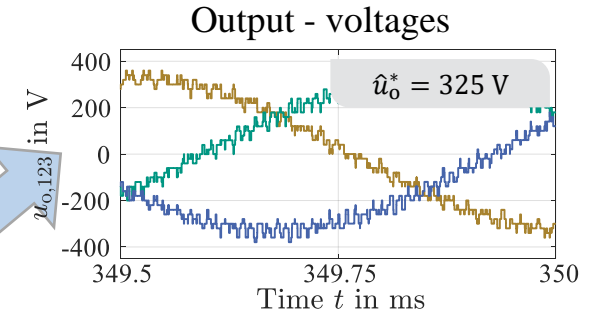
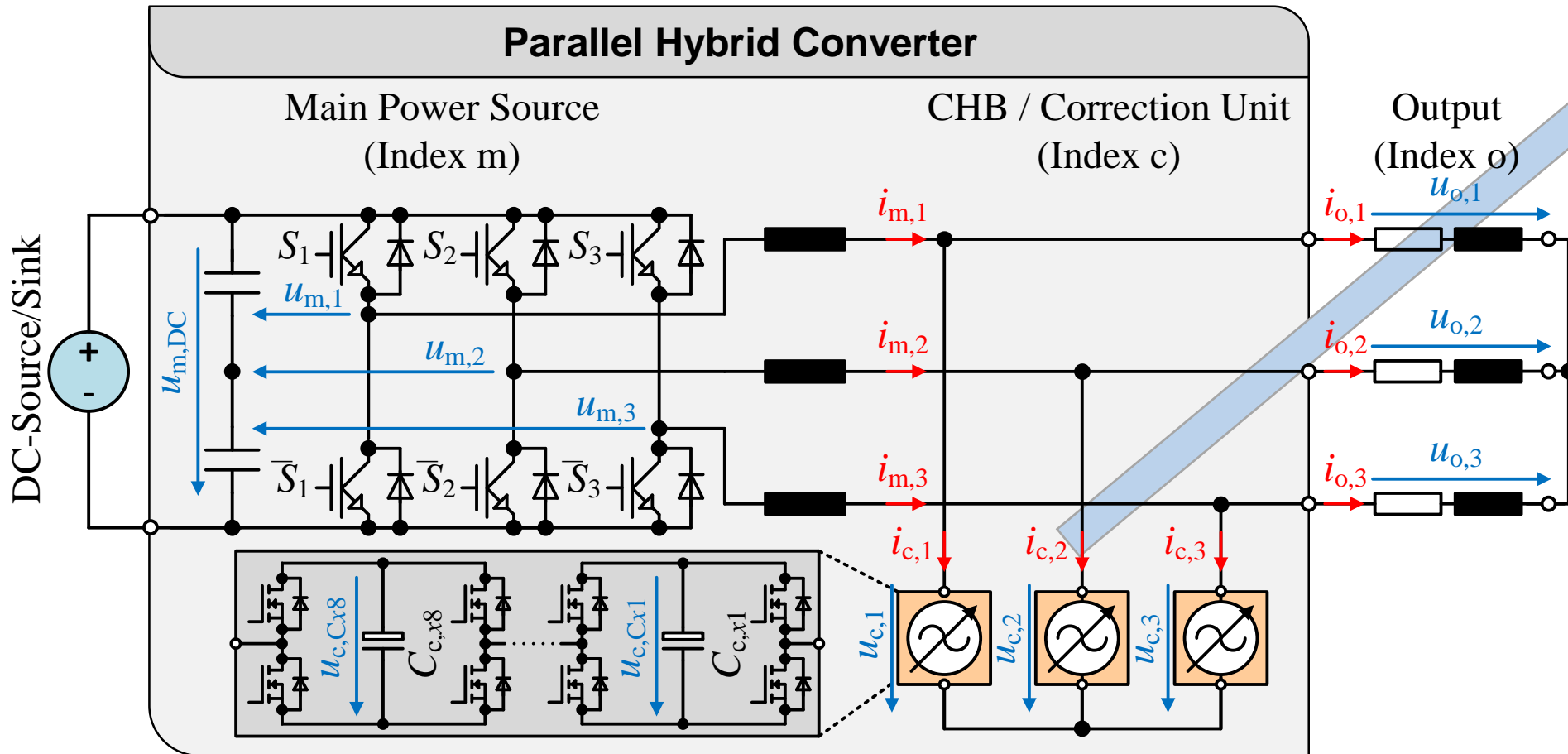

Cascaded H-Bridge based Parallel Hybrid Converter

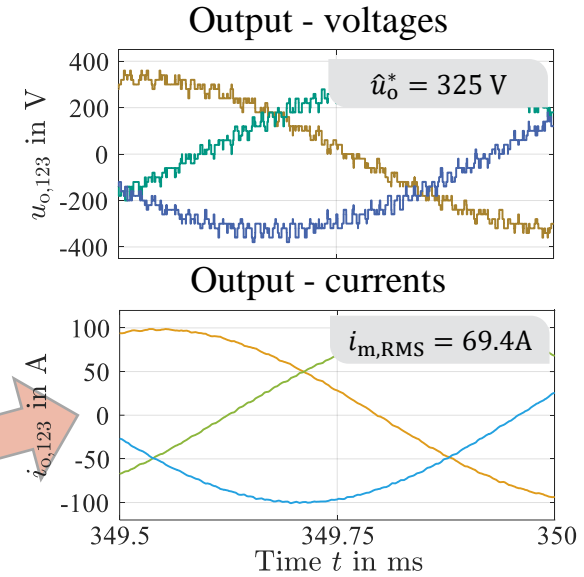
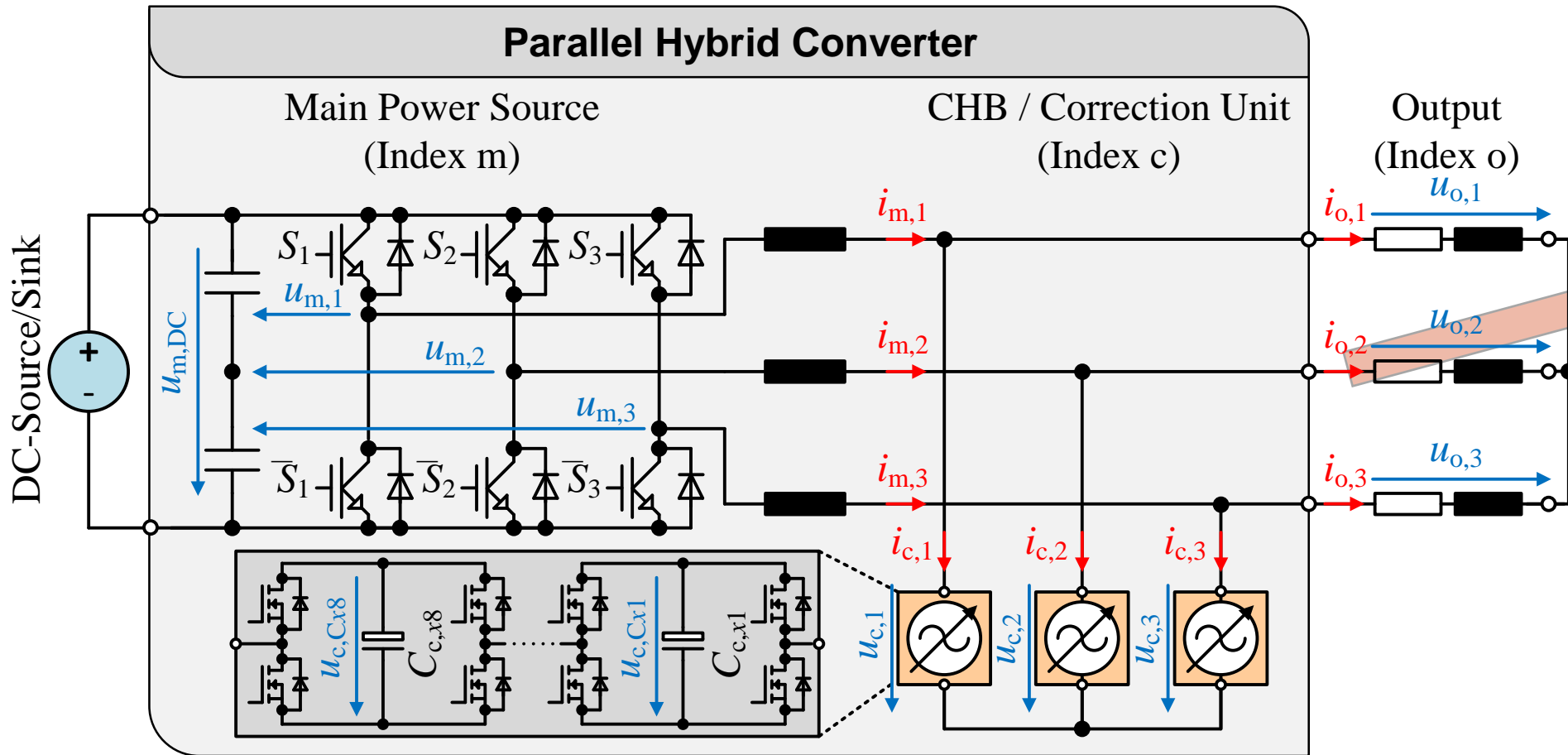

Cascaded H-Bridge based Parallel Hybrid Converter

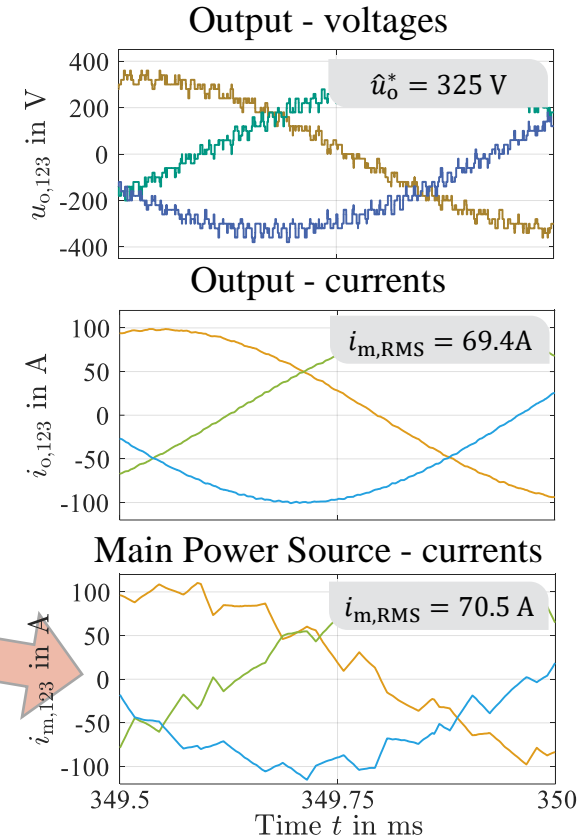
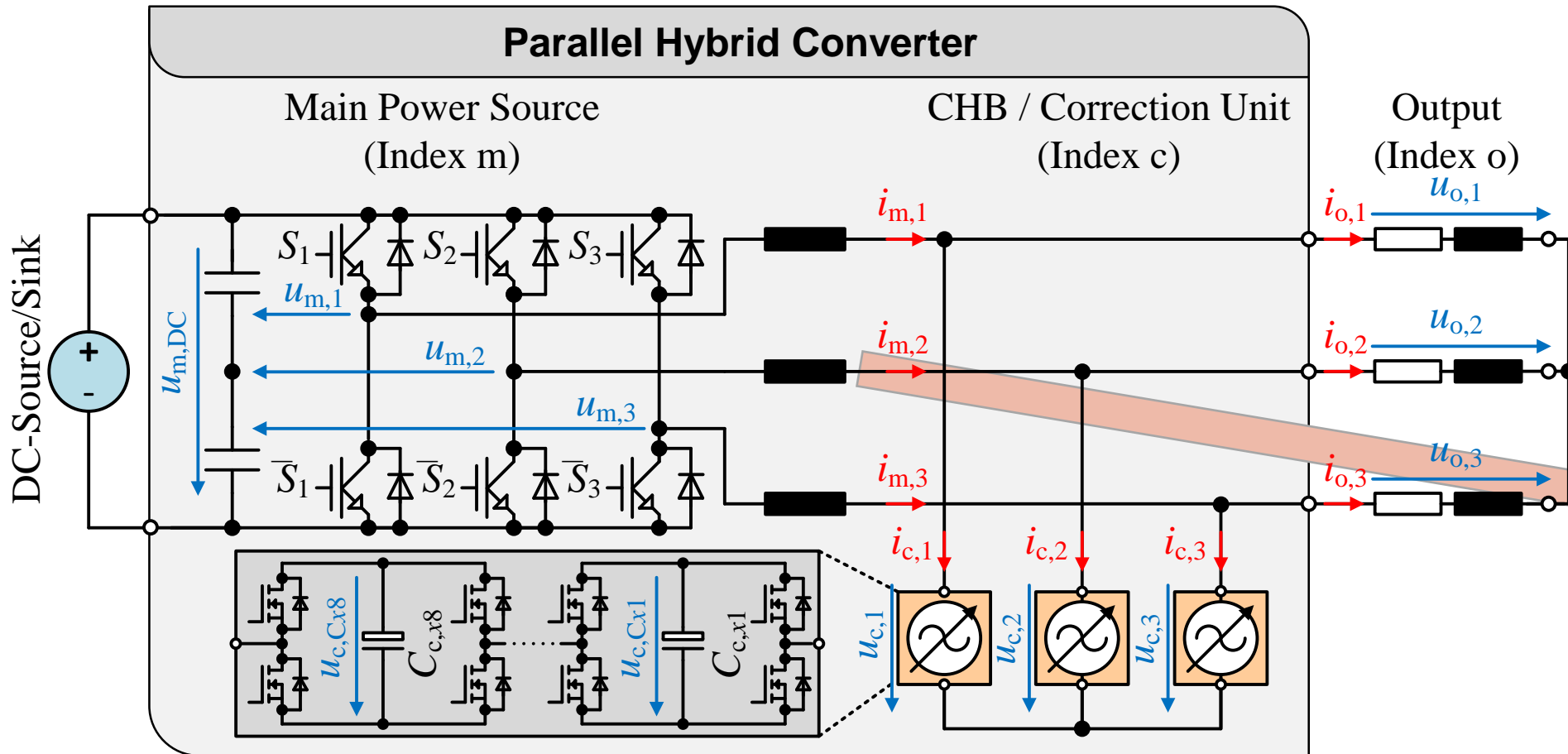

Cascaded H-Bridge based Parallel Hybrid Converter

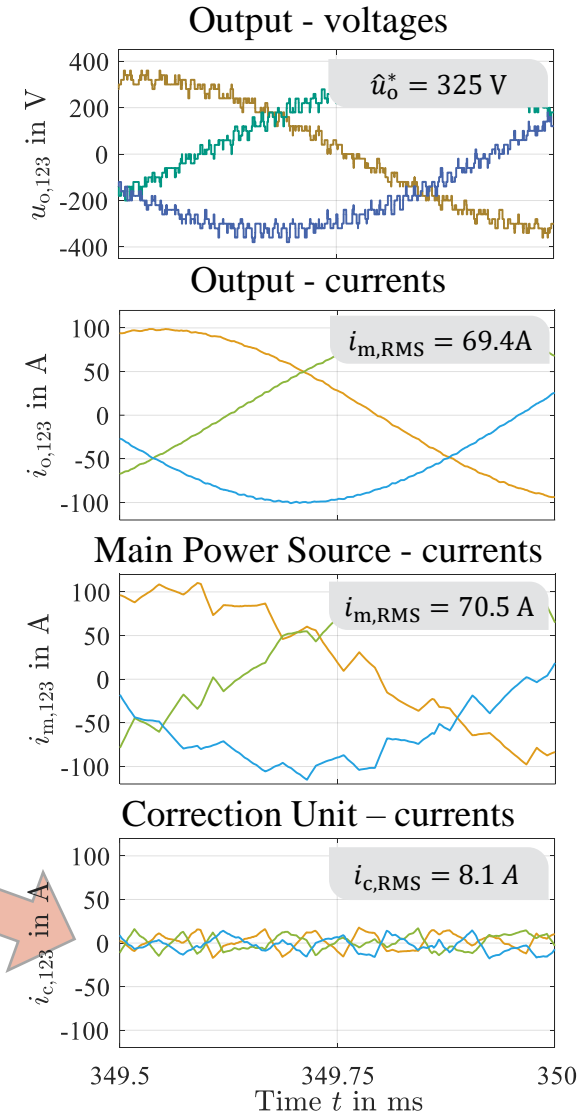
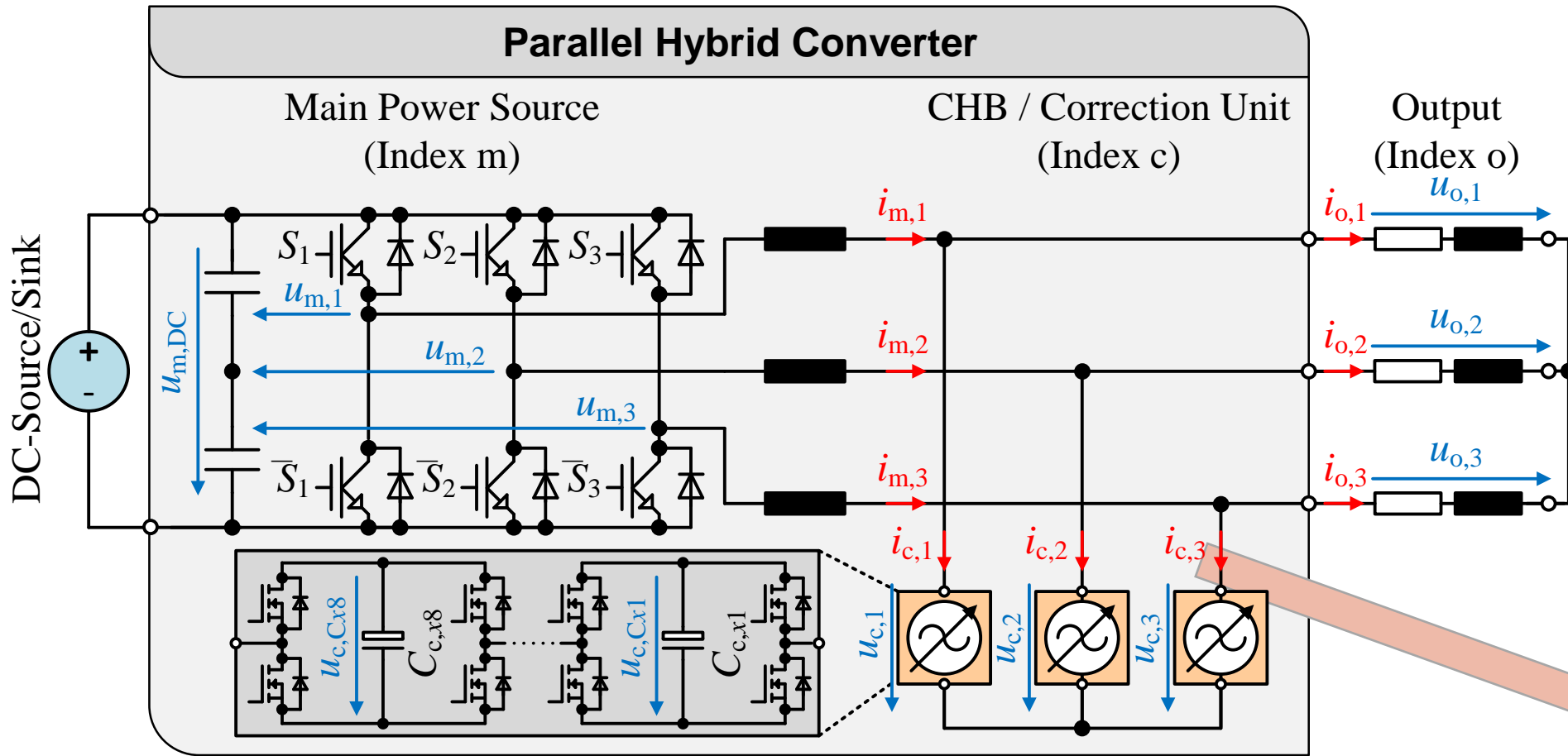

Cascaded H-Bridge based Parallel Hybrid Converter

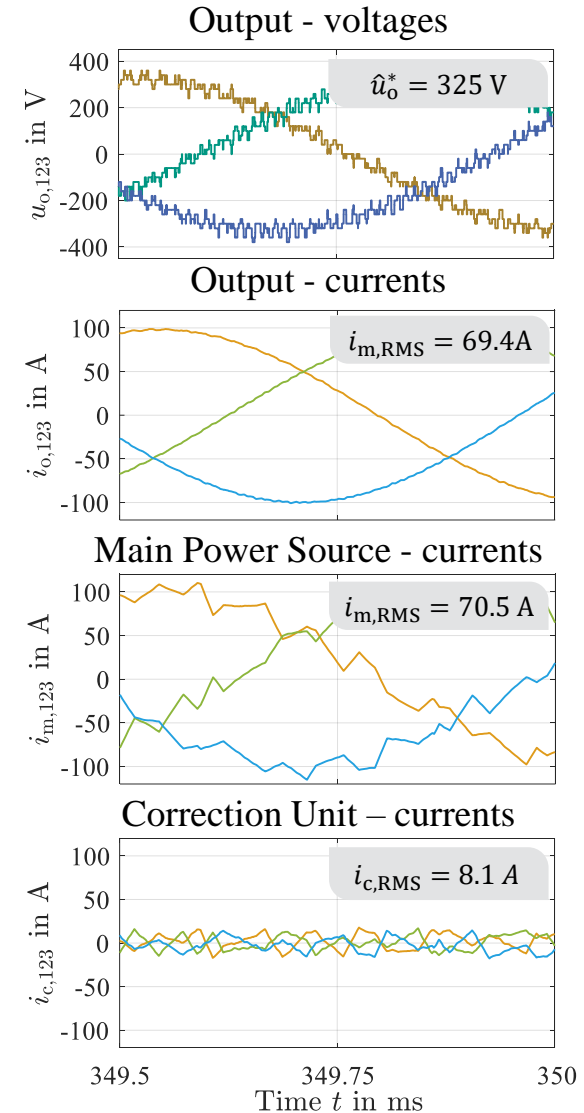
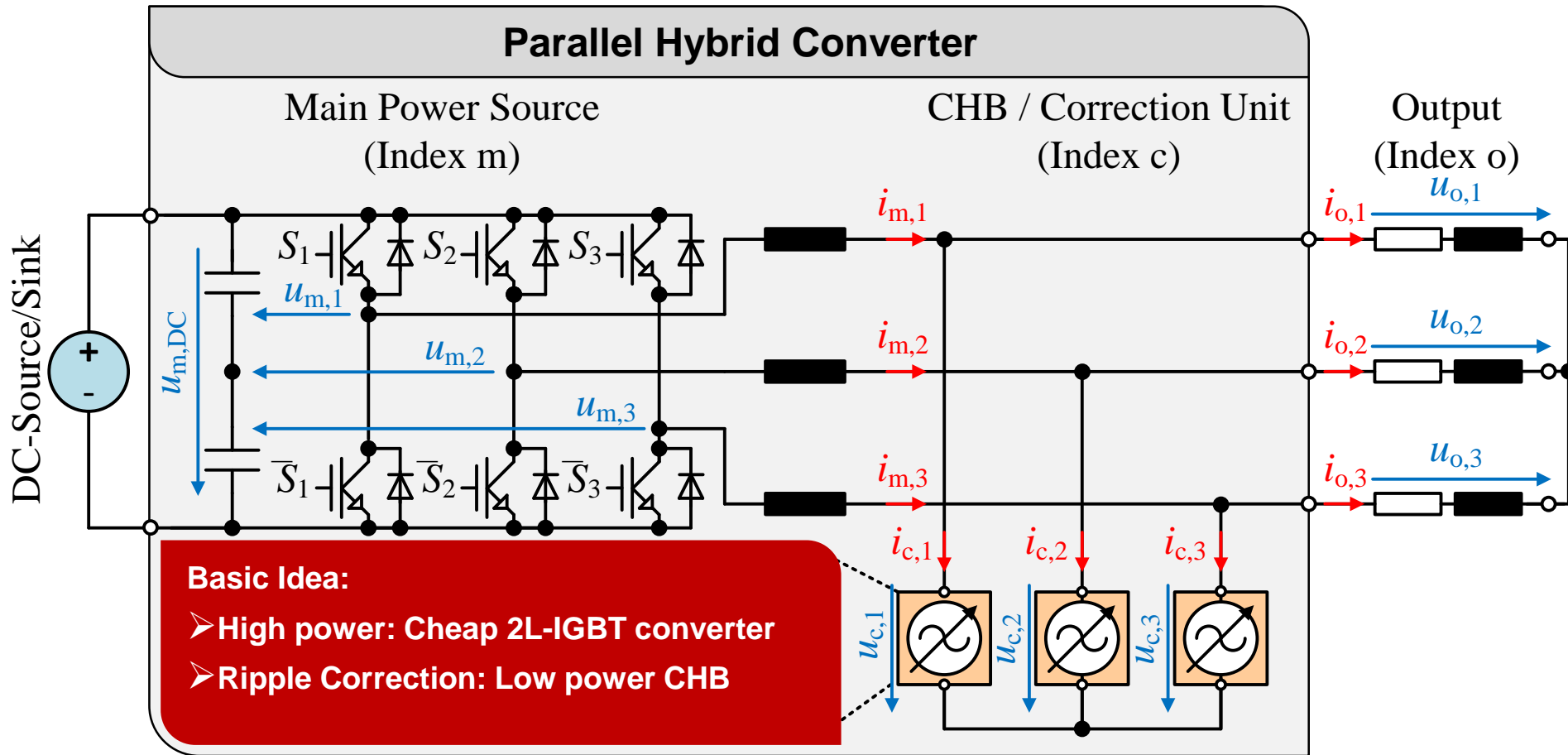

Simulation results with a RL-Load

Output voltages:

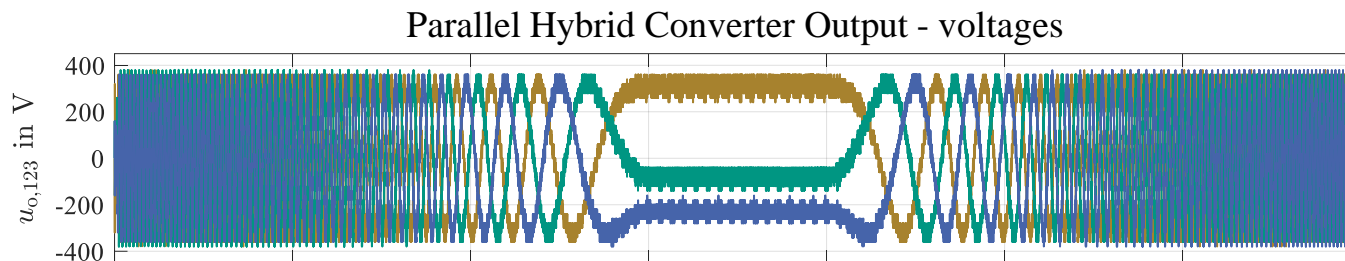

Output currents:

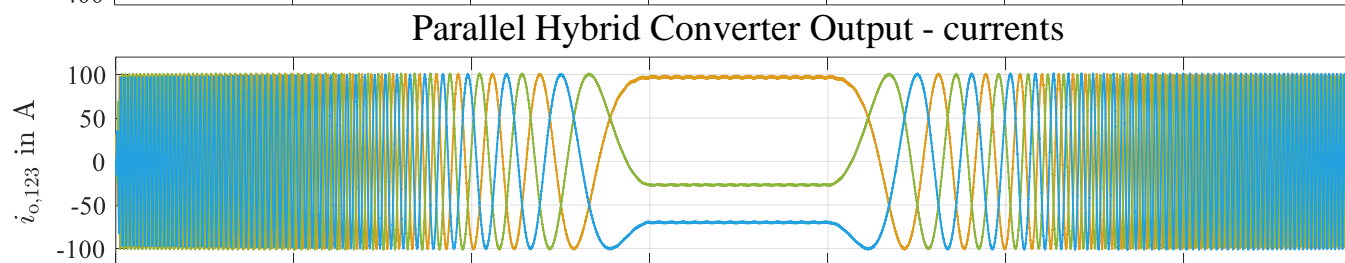

Main Power Source currents:

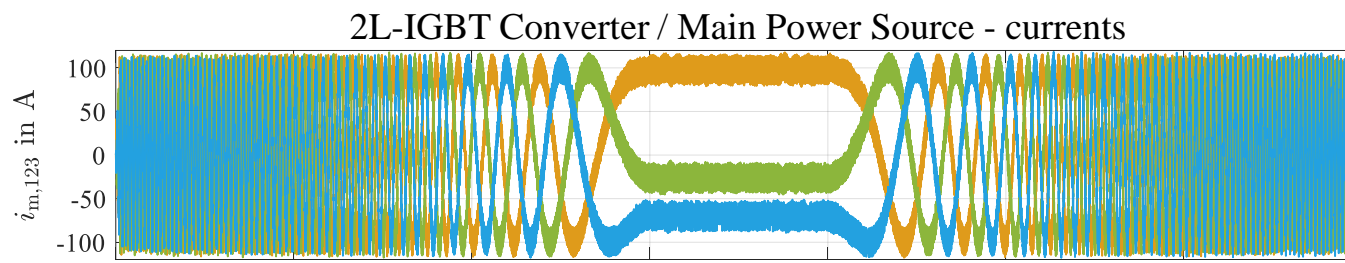

CHB / Correction Unit currents:

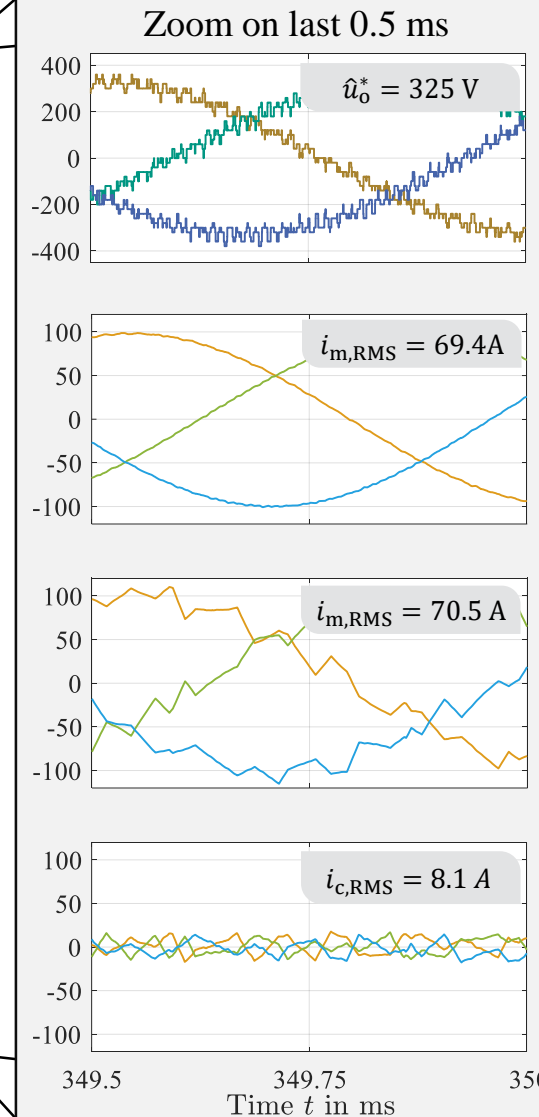
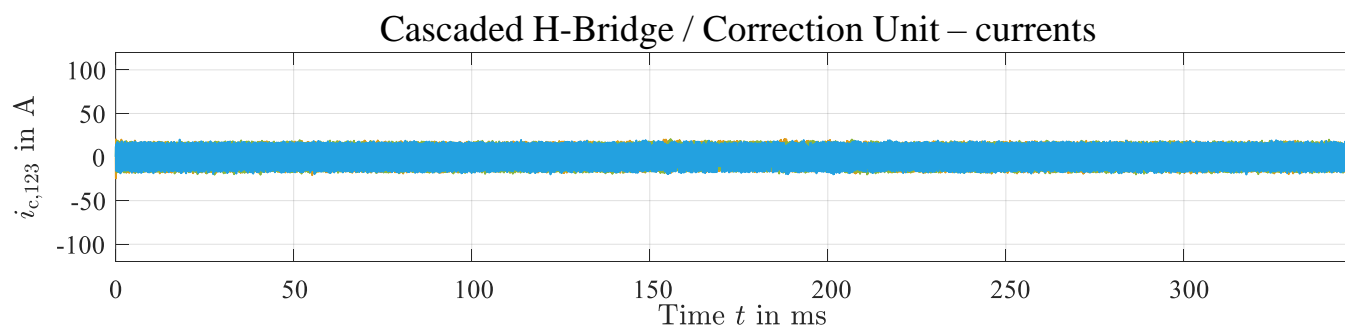

Thanks for your attention

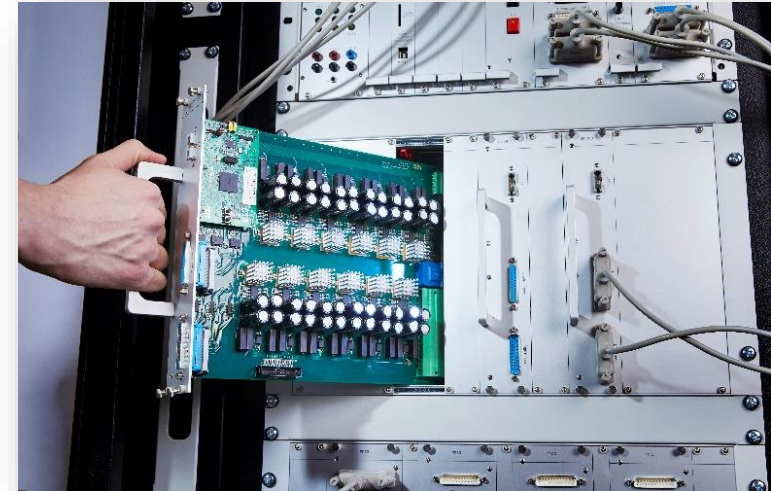

Lukas Stefanski

Kaiserstr. 12 • 76131 Karlsruhe • Germany

Phone: +49/721/608-46249

Email: lukas.stefanski@kit.edu

Web: www.eti.kit.edu