

PAPER • OPEN ACCESS

## Compression and thermal conductivity tests of Cryogel® Z for use in the ultra-transparent cryostats of FCC detector solenoids

To cite this article: V Ilardi *et al* 2020 *IOP Conf. Ser.: Mater. Sci. Eng.* **756** 012005

View the [article online](#) for updates and enhancements.



**EXTENDED ABSTRACT DEADLINE: DECEMBER 18, 2020**

**239th ECS Meeting**  
with the 18th International Meeting on Chemical Sensors (IMCS)

**May 30-June 3, 2021**

**SUBMIT NOW →**

The banner features a red top section with the deadline, a blue middle section with the meeting title and ECS logo, and a red bottom right section with the 'SUBMIT NOW' button. The background includes faint icons of a microscope, a person, and a gear.

# Compression and thermal conductivity tests of Cryogel<sup>®</sup> Z for use in the ultra-transparent cryostats of FCC detector solenoids

V Ilardi<sup>1,2</sup>, L N Busch<sup>1,3</sup>, A Dudarev<sup>1</sup>, T Koettig<sup>1</sup>, P Borges de Sousa<sup>1</sup>, J Liberadzka<sup>1</sup>, H Silva<sup>1</sup> and H H J ten Kate<sup>1</sup>

<sup>1</sup> CERN, POB Geneva 23, 1211 Geneva, Switzerland

<sup>2</sup> University of Twente, Faculty of Science and Technology, POB 217, 7500AA Enschede, The Netherlands

<sup>3</sup> Karlsruhe Institute of Technology, Karlsruhe, Germany

E-mail corresponding author: Veronica.Ilardi@cern.ch

**Abstract.** The Future Circular Collider (FCC) study includes the design of the detector magnets for the FCC-ee<sup>+</sup> (electron-positron) collider, requiring a 2 T solenoid for particle spectrometry, and for the FCC-hh (proton-proton) collider, with a 4 T detector solenoid. For both solenoids and their cryostats, CERN is developing an innovative and challenging design in which the solenoids are positioned inside the calorimeters, directly surrounding the inner tracker. For this purpose, the cryostats must be optimized to have maximum radiation transparency. They are structured as a sandwich of thinnest possible metallic shells for achieving vacuum tightness, supported by layers of low density and highly radiation transparent insulation material, still providing sufficient mechanical resistance and low thermal conductivity. In this respect, thermal and mechanical analysis of innovative insulation materials are currently being carried out. The first material of interest, Cryogel<sup>®</sup> Z, is shaped as a flexible composite blanket, which combines silica aerogel with reinforcing fibers and a density of 160 kg/m<sup>3</sup>. It allows a 4 m bore, 6 m long FCC-ee<sup>+</sup> detector solenoid cryostat with a total thickness of 250 mm. CERN has investigated the compression of Cryogel<sup>®</sup> Z under 1 bar equivalent mechanical load and its thermal conductivity between 10 K and room temperature, as well as the critical phenomena of thermal shrinkage and outgassing. We present the test results, as a first overview on the material.

## 1. Introduction

In the frame of the ongoing development of the next generation of particle colliders, CERN is designing multiple variants of Detector Magnets for the projected Physics Experiments at the Future Circular Collider (FCC), which includes electron-positron (ee<sup>+</sup>), electron-hadron (eh) and hadron-hadron (hh) collision detectors [1]. A first step machine may be the high-luminosity, high-precision FCC-ee<sup>+</sup>. A cutting-edge design shows the superconducting solenoid positioned inside the calorimeter, providing magnetic field for particle tracking in the inner detector. Its 3-D model, inspired by the so-called IDEA detector (International Detector Electron Accelerators), is shown in Figure 1.

The 4 m bore, 6 m long, 2 T and 170 MJ solenoid requires a cold mass and cryostat with extremely high radiation transparency and therefore lowest possible thickness and density, in order to minimize particle scattering [2, 3]. The classical cryostat sandwich comprising a relatively thick metallic vacuum vessel, radiation shield, MLI and solenoid cold mass, is in this concept replaced by a structure of very



thin metallic vacuum vessel walls, supported by an insulation material with sufficient mechanical resistance, as pictured schematically in Figure 2.

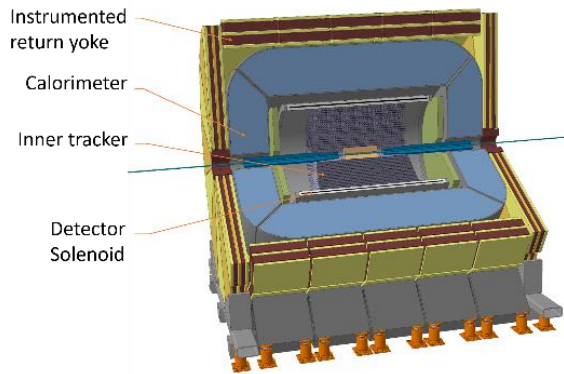

Figure 1. The FCC-ee<sup>+</sup> IDEA detector with an ultra-thin solenoid inside the calorimeter.

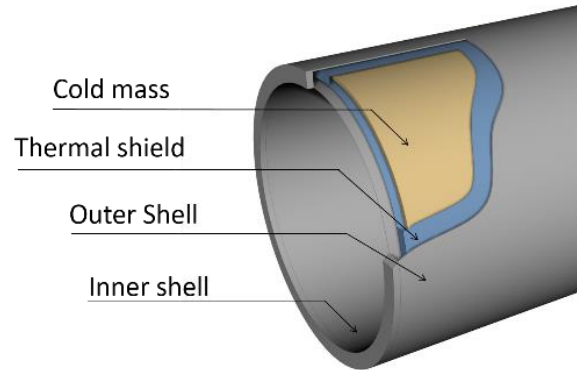

Figure 2. Design of the FCC-ee<sup>+</sup> cryostat for a 2 T, 4 m bore, 6 m long solenoid.

The same concept can even be applied to the much more demanding detector for the FCC-hh, comprising an ultra-thin 4T/4m bore solenoid around the inner detector. The innovative design has been developed starting from the research on novel and compatible insulation materials, which has led, among others, to Cryogel<sup>®</sup> Z as manufactured by Aspen Aerogels Inc. It is shaped as a flexible aerogel composite blanket, designed for insulating low temperature environments ranging from cryogenic temperatures to ambient. It combines silica aerogel with reinforcing fibers and it has a density of 160 kg/m<sup>3</sup> [4, 5].

Here we present the results of the compression and thermal conductivity tests conducted on Cryogel<sup>®</sup> Z and the effects of possible thermal shrinkage and outgassing of the material.

## 2. Mechanical behaviour of Cryogel<sup>®</sup> Z under different conditions of temperature and pressure

The innovative superconducting solenoid features ultra-thin vessel walls, which are supposed to wrinkle under vacuum load while maintaining vacuum tightness. Dense layers of Cryogel<sup>®</sup> Z filling the space between the thin vacuum wall and solenoid cold mass are required to sustain the atmospheric pressure. Two tests, performed under different conditions and setups, are conducted. First, the compression of Cryogel<sup>®</sup> Z at room temperature and atmospheric pressure is estimated by applying a compressive mechanical load of 1 bar. During the second test, Cryogel<sup>®</sup> Z, under vacuum, is cooled down in a bath of liquid nitrogen, in order to check critical aspects as outgassing and shrinkage of the material, in addition to the percentage of overall compression reached.

### 2.1. Compression test in 10 cycles at room temperature

Cryogel<sup>®</sup> Z comes as a blanket of 10 mm thickness. Ten cycles of mechanical compression were conducted on a stack of material consisting of 10 blankets, each 10 mm thick and with an area of 100 mm x 100 mm. The results of the first cycle of compression are shown in Figure 3.

Under a mechanical load equivalent to 1 bar, the compression of Cryogel<sup>®</sup> Z is 29.0% of the initial thickness at the first cycle and it increases up to the 29.8% at the last cycle. Compression hysteresis is observed as, by removing the load, the percentage of material recovered is equal to the 20% of the initial thickness at the first cycle and it decreases to 17% at the last cycle. It can be concluded that Cryogel<sup>®</sup> Z shows roughly the same mechanical behavior after 10 cycles, giving evidence that it does not get seriously damaged under 1 bar compression cycles. However, the creep behavior of the material should be investigated.

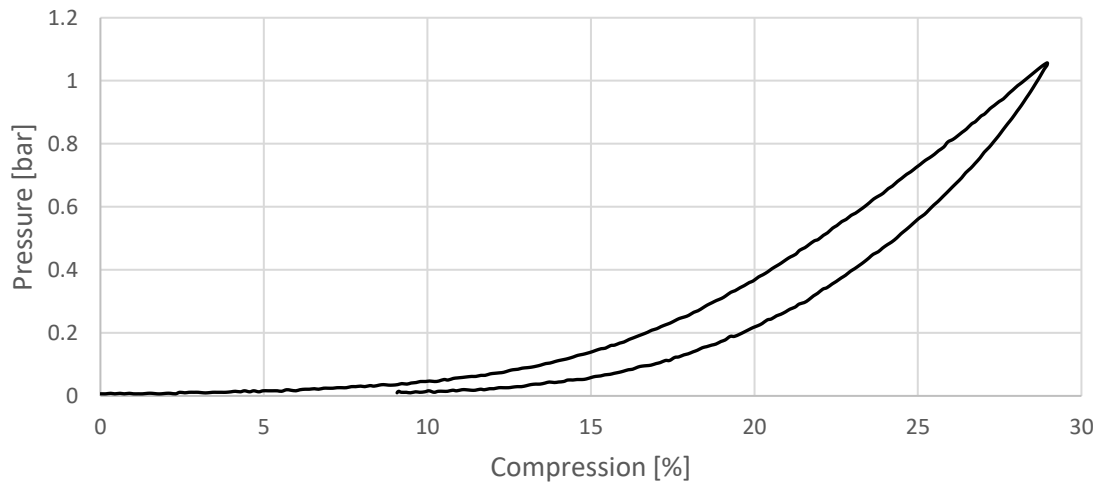

Figure 3. First compression cycle of Cryogel<sup>®</sup> Z at room temperature. Compressive pressure versus percentage of thickness reduction.

### 2.2. Thermal shrinkage test of compressed Cryogel<sup>®</sup> Z

In order to use Cryogel<sup>®</sup> Z as cryostat insulation, it is important to analyze the outgassing during pumping and the shrinkage of the material at low temperature. Figure 4 shows the setup that is vacuum pumped and cooled down in liquid nitrogen.

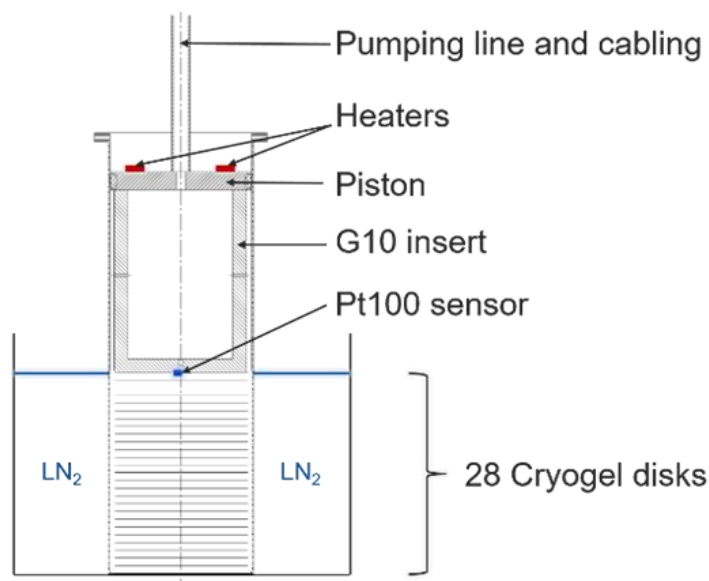

Figure 4. Test setup for contraction measurements of compressed Cryogel<sup>®</sup> Z.

It consists of a G10 cylinder of 484 mm height, filled with 28 discs of Cryogel<sup>®</sup> Z blankets of 155 mm diameter in close contact to the cylinder walls. A stainless steel piston with an O-ring seal ensures the leak tightness of the setup while the O-ring is kept at room temperature. To facilitate this, two electric heaters are placed on the piston and a 210 mm high G10 insert separates the O-ring from the stack of Cryogel<sup>®</sup> Z blankets. A Pt100 temperature sensor is placed on top of the Cryogel<sup>®</sup> Z blankets.

The first pumping cycle compresses Cryogel<sup>®</sup> Z to  $198.5 \pm 0.5$  mm, corresponding to 71% of the initial 280 mm height. Thus, the stack compressed of 29%, consistent with the test described in Section 2.1. Roughly 1 hour after releasing the load, the Cryogel<sup>®</sup> Z stack measures 265 mm, showing that the material recovered to 95% of the initial height (i.e. it kept the 5% height reduction). A second pumping cycle compresses the Cryogel<sup>®</sup> Z stack by  $67.0 \pm 0.5$  mm, bringing the stack back to a 71% of the initial height.

The pressure decreasing at the first pumping cycle, see Figure 5, shows a clear holding level at 2.2 mbar, indicating outgassing of the material. By placing the setup inside the liquid N<sub>2</sub> bath, the minimum temperature measured by the Pt100 sensor is 180 K, so an average minimum temperature between 80 K and 180 K can be assumed for Cryogel<sup>®</sup> Z. No relevant displacement of the piston is observed, given the accuracy of  $\pm 0.5$  mm. Knowing the thermal expansion of G10 [6], the combined contraction of vessel walls and insert is 0.5 mm. Thus, Cryogel<sup>®</sup> Z may contract within our measurement accuracy, which is between 0 and 1 mm ( $0 \div 0.5\%$  of the compressed height of Cryogel<sup>®</sup> Z stacks). Since the phenomena needs deeper study, new tests, with higher instrumentation accuracy, will be performed.

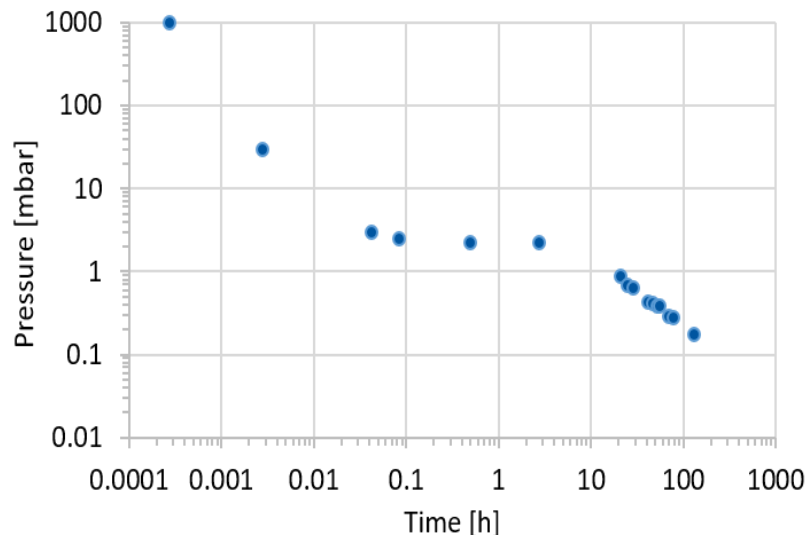

Figure 5. First pump down of a stack of Cryogel Z compressed layers at 293 K, pressure versus time.

### 3. Thermal conductivity measurements of Cryogel Z

At the CERN Central Cryogenic Laboratory, a thermal conductivity study was conducted through small-scale measurements. Cryogel<sup>®</sup> Z samples were tested between 10 K and 275 K, at atmospheric pressure, while compressed to 70% of their initial thickness. Two tests were conducted, based on different measurement methodologies: the integral and differential one [7]. The setup and results obtained from the integral method are described in our previous publication [8]. In the following paragraphs, we briefly outline the main features of the setup and compare the integral and differential approaches and their results.

#### 3.1. Test setup and sample description

Two Cryogel<sup>®</sup> Z samples of 22 mm diameter and 10 mm thickness are mounted in between three copper plates of the sample holder. The discs are compressed in transverse direction, from 10 mm to an effective thermal length  $L$  of 7 mm, corresponding to 30% densification. The compression is provided by three screws between the top and bottom plates. To provide thermal contact, three copper braids are bolted to the external plates. Top and bottom plates are, therefore, kept at the same temperature, while the central plate is thermally decoupled from them, so that the heat load is only transferred through

Cryogel<sup>®</sup> Z. The sample holder is bolted to the second stage of a Sumitomo two-stage pulse tube refrigerator (PTR), which delivers 1 W of cooling power at 4.2 K on the second stage [9]. For both tests, a calibrated TVO temperature sensor is positioned on the bottom plate, while two Cernox sensors are placed on top and center plates, calibrated against the TVO. The heat load of 0 to 425 mW is provided by electric heaters.

In order to minimize radiation losses, the second stage has its own copper thermal shield wrapped in MLI. An overview of the setup is given in Figure 6.

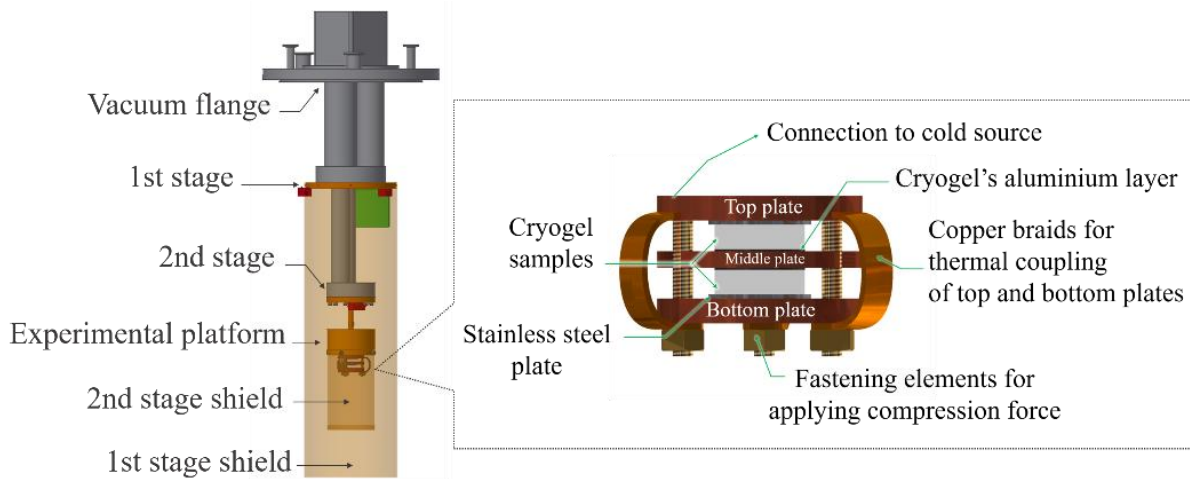

Figure 6. Test setup for Cryogel<sup>®</sup> Z thermal conductivity measurements [10].

### 3.2. Integral and differential measurement methods

A characteristic measurement procedure is to stabilise the experimental platform at its lowest possible temperature (about 2.6 K) and then incrementally increasing the heat load on the heated plates. The heated plates' temperatures are allowed to stabilise and a measurement point is taken, after which the heat load is increased for a new data point.

The thermal conductivity integral method, followed during the first test, consists of keeping the low temperature ends of the sample, the top and bottom copper plates, at a constant temperature, while progressively heating the other end, the center copper plate, to a higher temperature, and measuring the steady-state temperature gradient established between both ends.

The thermal conductivity integral is defined from the Fourier equation for steady state unidirectional conductive heat flux through a constant cross-section area as following:

$$I = Q \frac{L}{A} = \int_{T_c}^{T_h} \lambda(T) dT, \quad (1)$$

where  $Q$  is the effective heat flux transferred through the sample and corrected for radiation and wiring losses,  $A$  is Cryogel's cross-sectional area,  $L$  is the distance between the cold and warm ends that are at temperature  $T_c$  and  $T_h$ , respectively. All variables  $Q$ ,  $A$ ,  $L$ ,  $T_c$  and  $T_h$  are measured. As  $T_c$  is kept constant, the thermal conductivity  $\lambda$  at  $T_h$  is equal to the gradient of the integral of the thermal conductivity:

$$\nabla I(T_c, T_h) = \frac{\partial}{\partial T_c} I(T_c, T_h) + \lambda(T_h) - \frac{\partial}{\partial T_h} \int \lambda(T) dT \Big|_{T_c} = \lambda(T_h). \quad (2)$$

From equations 1 and 2, the thermal conductivity at  $T_h$  can be expressed as function of the measured change in effective heat flux. Thus, the thermal conductivity data points are plotted as a function of  $T_h$ .

For the second test, the thermal conductivity differential method is applied: once the experimental platform is stabilized at its lowest possible temperature of 2.6 K, it starts to be heated up, keeping a  $\Delta T$  between the low temperature top and bottom copper plates and the high temperature center copper plate.



The  $\Delta T$  is kept as low as possible, below 300 mK, so that, using equation (1),  $\lambda$  can be considered constant for every  $\Delta T$  analyzed:

$$\lambda = Q \frac{L}{A (T_h - T_c)}. \quad (3)$$

### 3.3. Measurement results

The results are shown in Figure 7. Within the limit set by the accuracy of the instruments, the trends of the data points are fairly consistent. The data took into account some corrections of the effective heat load transferred across the samples. The conduction loss through both Cernox sensor and electric heaters was estimated at 3% of the applied heat load, while the heat loss by radiation of the middle plate to the inner thermal shield was 8% of the applied heating power for the highest plate temperature. The estimated maximum measuring error is 30%, taking into account the accuracy of voltmeters and current source for heaters and sensors, of the calibrated Vernier caliper for the sample cross section, active length and the thermal shrinkage of Cryogel<sup>®</sup> Z.

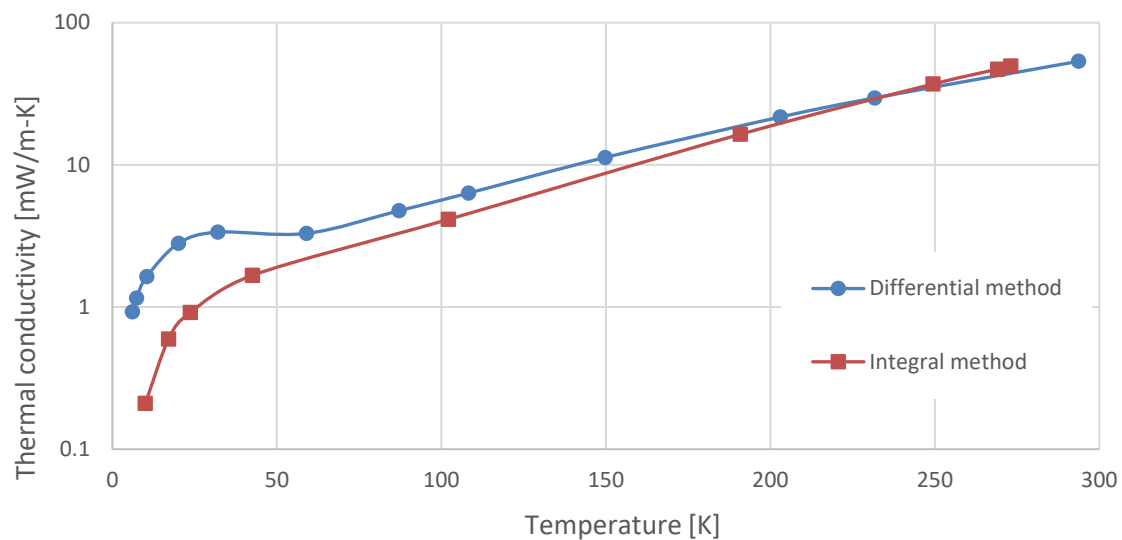

Figure 7. Comparison between the thermal conductivity measurements conducted on Cryogel<sup>®</sup> Z through the differential and integral methods.

## 4. Conclusion

From the compressive tests realized, Cryogel Z shows, under 1 bar mechanical pressure, a displacement varying from -29.0% to -29.8% of the initial height, over ten compressive cycles. The compression hysteresis is also consistent with a recovered material percentage between 17 and 20%. Therefore, the mechanical behavior of the material can be considered fairly stable and we can assume that Cryogel<sup>®</sup> Z does not get heavily damaged under 1 bar pressure.

The thermal conductivity of Cryogel<sup>®</sup> Z, measured on a small-scale setup, ranges from 0.2 mW/m-K at 10 K, to 50 mW/m-K at 273 K. This identifies Cryogel<sup>®</sup> Z as a promising insulation material for use in the ultra-thin cryostats of the FCC detector magnets. However, the thermal conductivity was measured for the bulk material. The cryostats of the detector solenoids of the FCC-ee<sup>+</sup> and FCC-hh would be filled with several blankets of Cryogel<sup>®</sup> Z. The interfaces between those should, in principle, reduce the heat load transferred. In addition, because of the small dimension of the samples' cross section used for the tests, the measurements may be affected by the samples' boundary conditions. Therefore, a large-scale test setup has been designed and manufactured at CERN, comprising vacuum vessel walls, thermal shield and cold mass. A heat transfer analysis, using multiple blankets of Cryogel<sup>®</sup> Z as interposer between the parts, is currently being carried out.

## References

- [1] FCC Collaboration, Conceptual Design Report of the Future Circular Collider, 2019.
- [2] Bielert E. *et al.* 2019 Superconducting detector magnets baseline designs for particle physics experiments at the Future Circular Collider *IEEE Trans. Appl. Supercond.* **29** no. 5.
- [3] Kulenkampff T., Dudarev A., Ilardi V., Mentink M., Silva H., Bielert E. and Ten Kate H.H.J., Conceptual development of a novel ultra-thin and transparent 2 T superconducting detector solenoid for the Future Circular Collider, *IEEE Trans. Appl. Supercond.* **29** no. 5, 2019.
- [4] Fesmire J. E., Rouanet S. and Ryu J., Aerogel-based cryogenic superinsulation, *Adv. in Cryog. Eng.* **44** 219-26, 1998.
- [5] Aspen Aerogels, Cryogel Z technical specification sheet, 2017.
- [6] Ekin J.W., *Experimental techniques for low-temperature measurements*, Book, OUP Oxford, 2006.
- [7] Hust J.G. and Lankford A.B., Comments on the measurement of thermal conductivity and presentation of a thermal conductivity integral method, *Intern. Journ. Thermophysics* **3** 67-77, 1982.
- [8] Ilardi V. *et al.*, Development of light and highly radiation transparent cryostats for FCC detector magnets: first analyses of insulation materials, *IEEE Trans. Appl. Supercond.* **28** 2019.
- [9] Sumitomo RP-082B2 pulse tube cryocooler technical specification sheet.
- [10] Borges de Sousa P., Koettig T., Measurement report: Cryogel<sup>®</sup> Z thermal conductivity measurements between 3 K and 273 K, 2017.
- [11] American Society for Testing and Materials. ASTM Standard C177, 2019.