

Fusion Seminar  
at Gesellschaft Chinesischer Physiker in Deutschland (GCPD) e.V.  
Online, 17 April, 2022



# Status of DEMO HCPB Breeding Blanket in Europe

Guangming Zhou, Lead Engineer  
On behalf of the HCPB BB Team

[guangming.zhou@kit.edu](mailto:guangming.zhou@kit.edu)





1. Why Breeding Blanket?
2. What is a HCPB?
3. EU-DME0 Top-Level Requirements
4. The current HCPB Breeding Blanket
5. Challenges
6. Conclusions

# Role of tritium in D-T fusion power plants

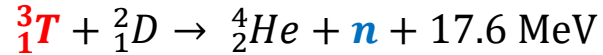

Tritium ( $T$ ) has a half-life of 12.3 years.  $T$  decays at a rate of 5.5%/yr.

1 GW fusion (thermal) power device:  
~56 kg  $T$  per full power year (fpy).

2 GW EU-DEMO fusion power: ~112 kg  $T$  per fpy

Global  $T$  inventory: Heavy Water ( $\text{D}_2\text{O}$ ) Reactors (CANDU)

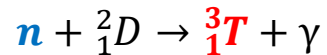

Need to produce  $T$

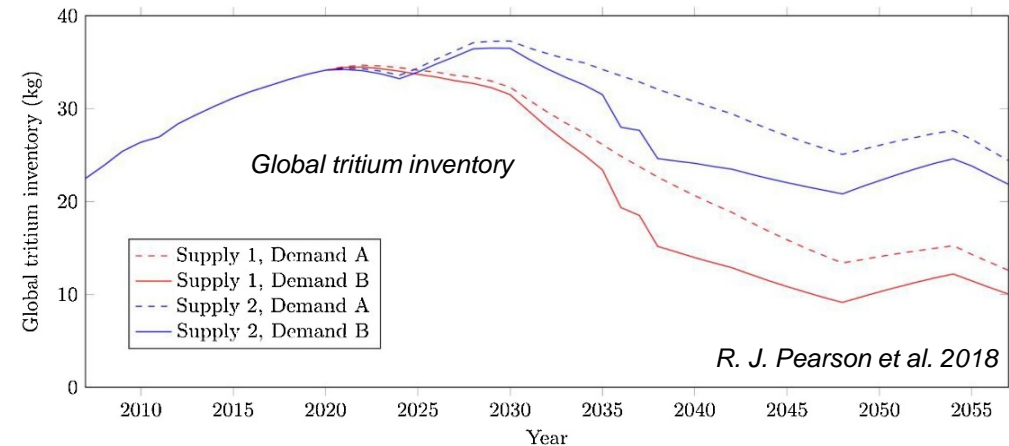
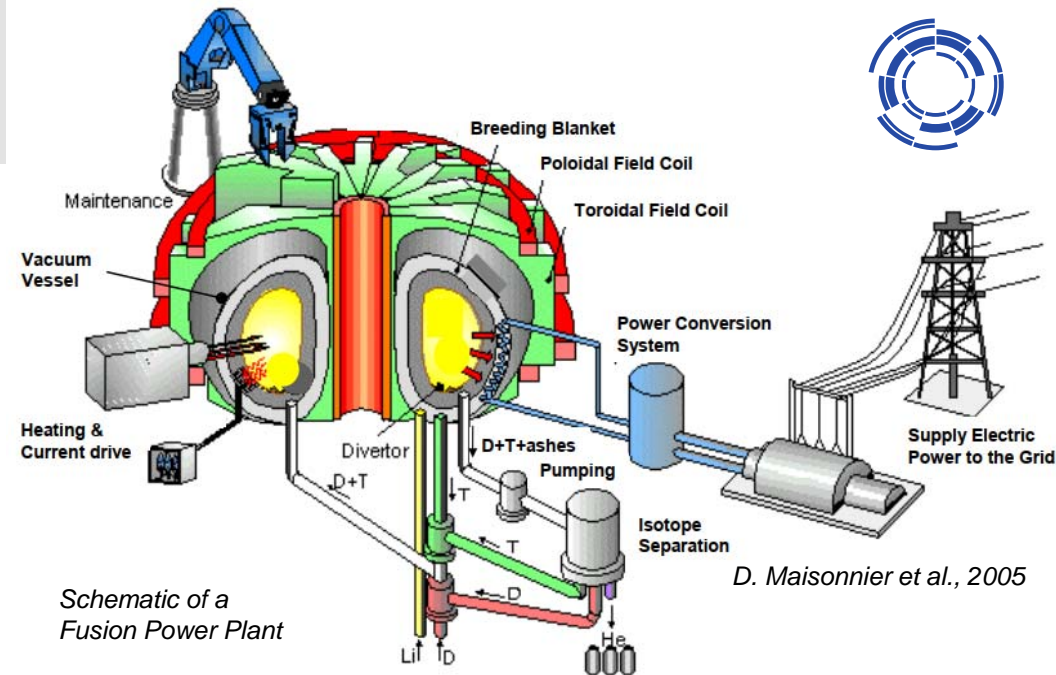



# Why Breeding Blanket (BB)?

## ➤ Main functions of the blanket:

- tritium breeding => tritium self-sufficiency
- heat removal => electricity production
- shielding => protect magnets from neutrons

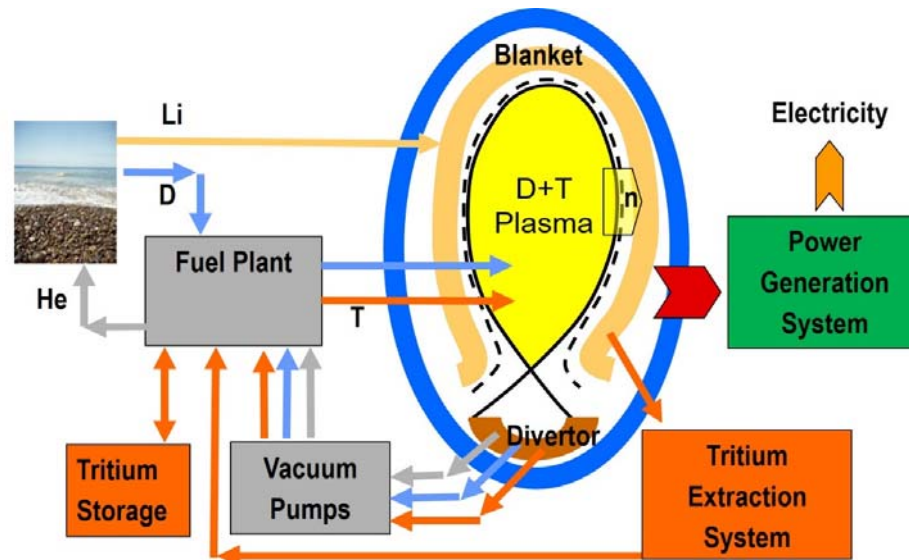
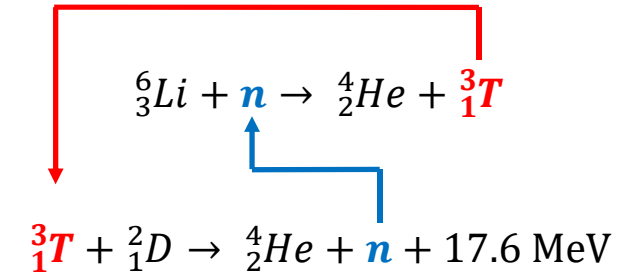

Credit: L. V. Boccaccini

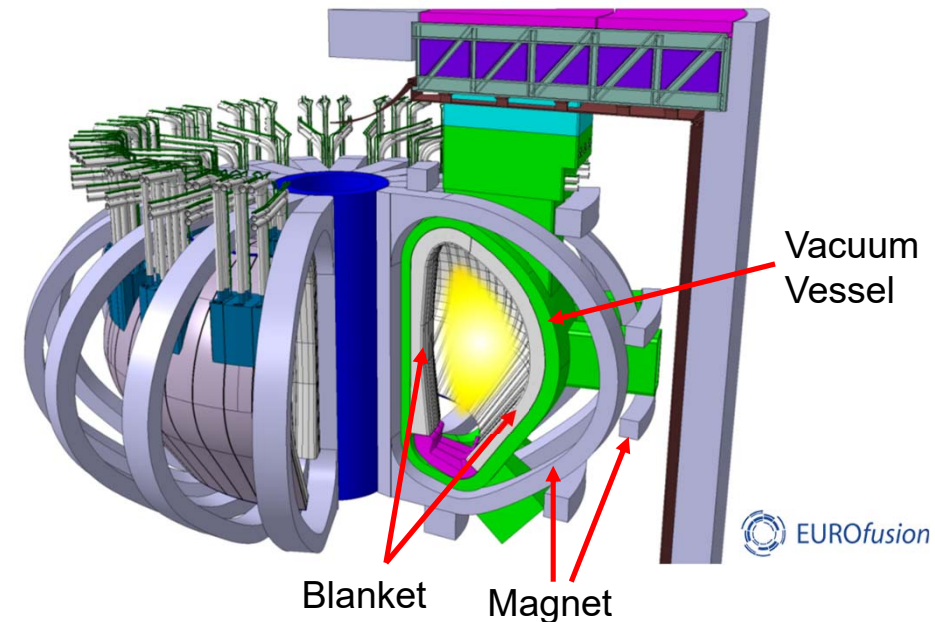

G. Zhou, Status of DEMO HCPB Breeding Blanket in Europe, Fusion Seminar at GCPD e.V., Online, 17 April 2022.

# Work Package Breeding Blanket in EUROfusion



EUROfusion

Org. Chart

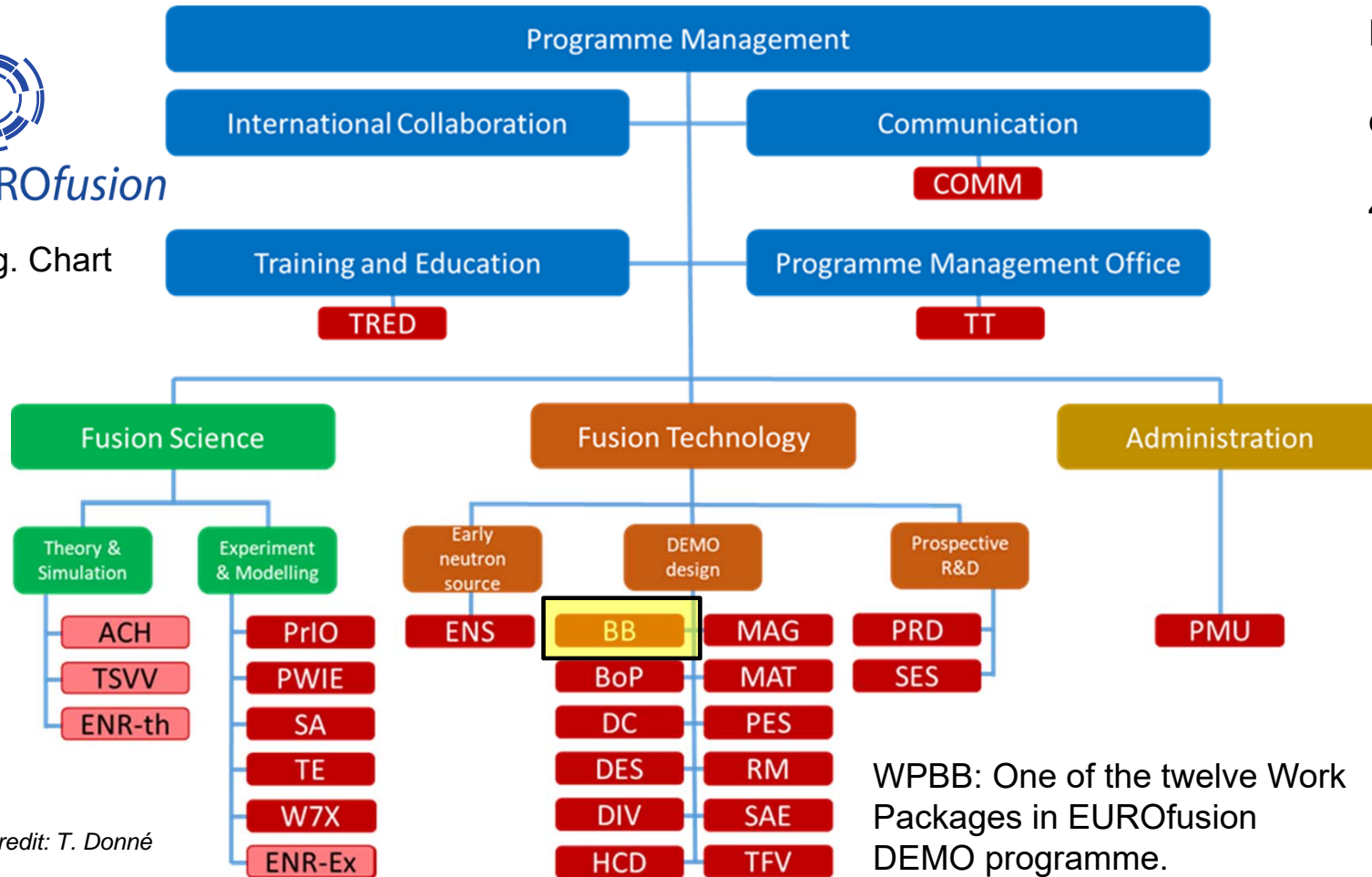

Credit: T. Donné

EUROfusion: 30 research institutes +150 affiliated universities from 28 countries.

4000 scientists and engineers.

EUROfusion coordinates the joint European efforts on developing fusion energy.

Budget:  
2014-2020 (7 years)  
1.2 billion Euro

2021-2025 (5 years)  
1.0 billion Euro

WPBB: One of the twelve Work Packages in EUROfusion DEMO programme.

Source: T. Donné

# HCPB BB in Work Package Breeding Blanket (WPBB)



2021-2025  
 WPBB resource: 16.4 million Euro annually  
 HCPB BB resource: 4.43 million Euro annually  
 Yearly tasks: 33  
 KIT, BUTE, CEA, CIEMAT, Uni Latvia,, PoliTo

WPBB Project Leader 

EUROfusion DEMO Central Team

TER: Tritium Extraction and Removal



LE of HCPB BB



LE of HCPB TER



LE of WCLL BB



LE of WCLL TER

LE: Lead Engineer

System Design & Modelling

Technology R&D

Design & Analyses

Design-supporting analyses

Nuclear analysis

He flow modelling

Thermal hydraulic analysis

Pebble bed modelling

Structural analysis

Tritium transport modelling

CAD office

- Solid breeder development
- Neutron multiplier development
- Helium cooling technology
- FW Manufacturing
- FW coating
- Prototypical Mock-up testing



1. Why Breeding Blanket?
2. What is a HCPB?
3. EU-DME0 Top-Level Requirements
4. The current HCPB Breeding Blanket
5. Challenges
6. Conclusions



## 2. What is a HCPB?

- **Helium Cooled Pebble Bed Breeding Blanket (HCPB BB)**

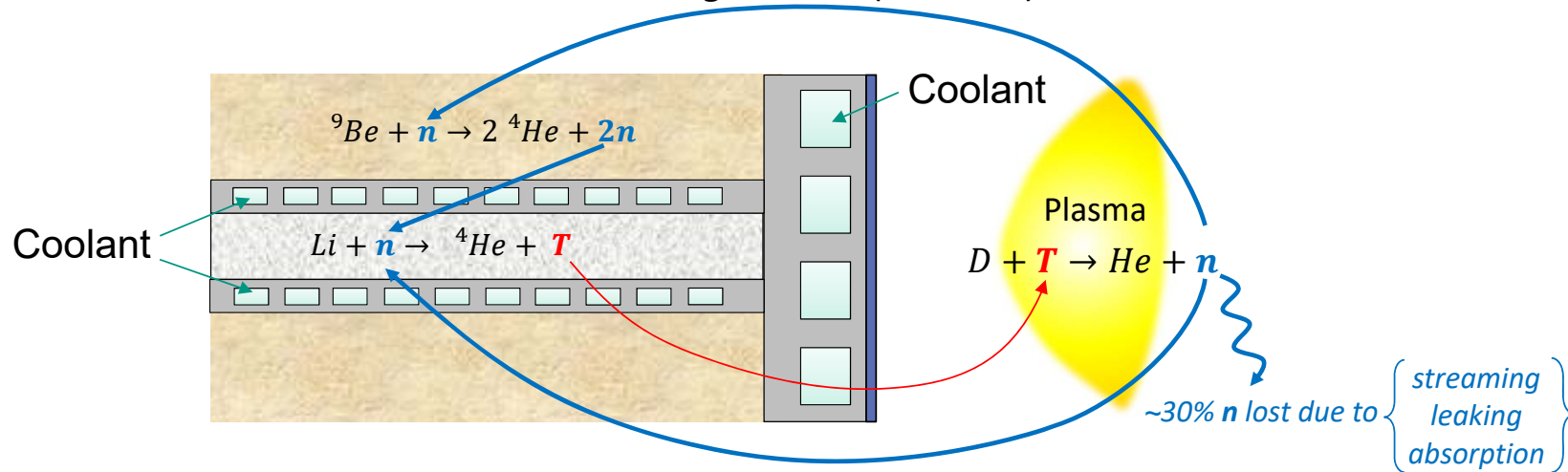

- Tritium Breeding Function

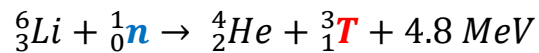

↳ Li compound (Li ceramics) as **T** breeder

- Structural material: Reduced Activation Ferritic Martensitic (RAFM) steel, Eurofer-97

- Neutron multiplier (NM) function:

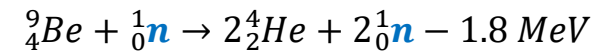

↳ Be/Beryllides as **n** multiplier

- Heat extraction: Helium (HTR-like)

Coolant Temp: 300°C – 520°C





1. Why Breeding Blanket?
2. What is a HCPB?
3. EU-DMEO Top-Level Requirements
4. The current HCPB Breeding Blanket
5. Challenges
6. Conclusions



### 3. Top-Level Requirements

- **Reactor Availability** > 30%
- **Tritium Breeding Ratio (TBR):**  $TBR_{\text{required}} \geq 1.05$ ,  $TBR_{\text{design}} \geq 1.15$  (w/o BB loss of coverage)
- **Neutron shielding:**
  - Nuclear heating in TFC < 50 W/m<sup>3</sup>
  - Vacuum vessel (VV) damage < 0.2dpa/fpy
  - He production in steel structures to be rewelded < 1appm/fpy
  - Shutdown Dose Rate in accessible regions < 100 $\mu$ Sv/hr
- **Temperature design limits:**
  - Eurofer-97: 350°C (DBTT\*) – 550°C ( $S_{\text{creep}}$ )
- **Thermo-mechanics and design**
  - Fulfilment of criteria in selected nuclear codes and standards (ASME, RCC-MRx,...)
  - Selected code: RCC-MRx 2018 (DEMO specific code under development, SDC-DC)
    - Stress limits under P-type (excessive deformation, plastic collapse, creep) and S-type damage (ratcheting, fatigue, creep-fatigue) modes, fast fracture mode if embrittlement occurs
    - Component design, materials, manufacturing and joining qualification following rules defined in codes

### 3. EU-DEMO Blanket Segmentation (1/2)



- EU DEMO Tokamak Baseline 2017 (latest reference,  $R_0=9\text{m}$ ,  $r=2.9\text{m}$ ,  $P_{\text{fus}}\approx 2\text{GW}$ )

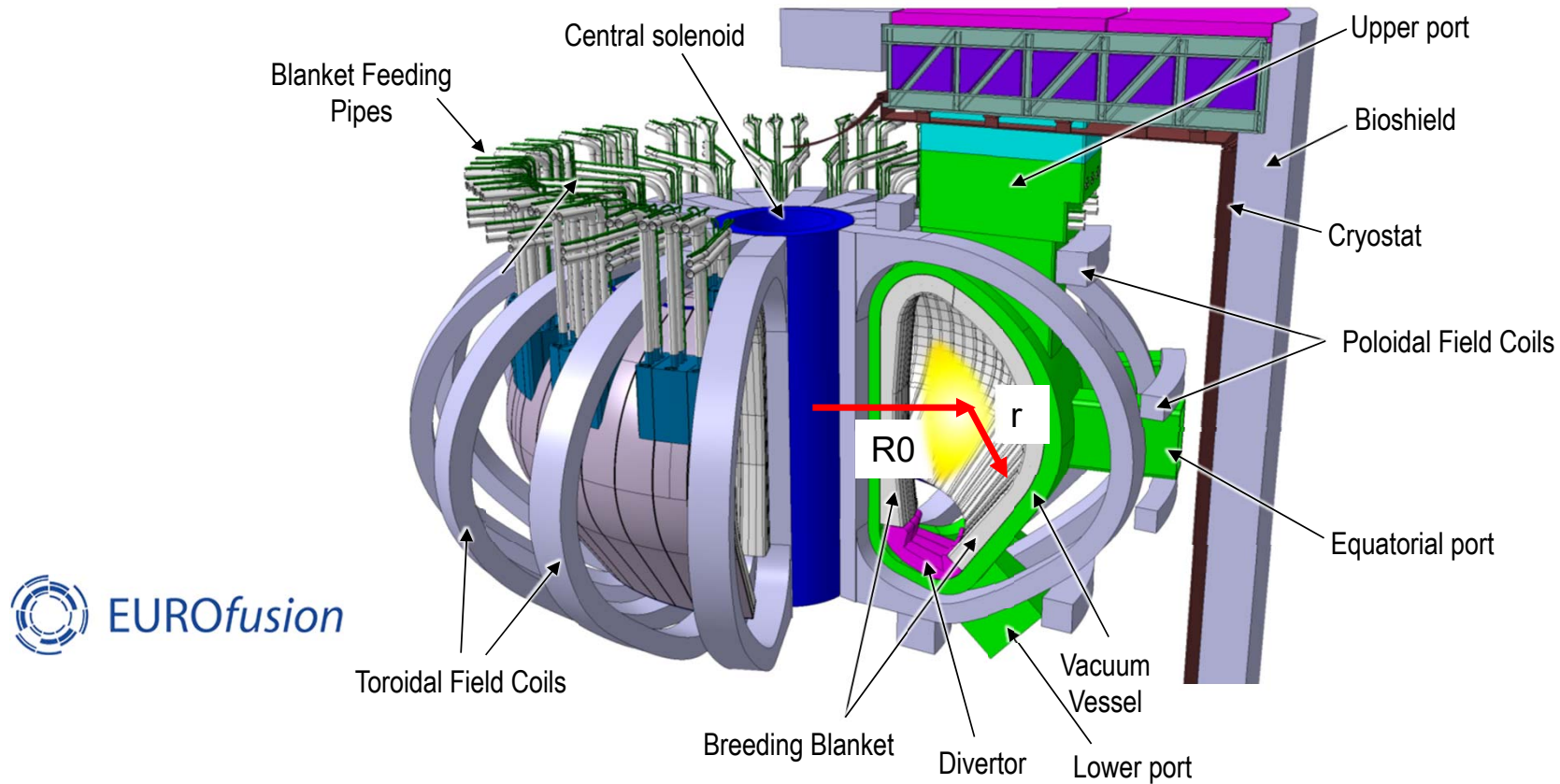



### 3. EU-DEMO Blanket Segmentation (2/2)

- EU DEMO Tokamak Baseline 2017 (latest reference,  $R_0=9\text{m}$ ,  $r=2.9\text{m}$ ,  $P_{\text{fus}}\approx 2\text{GW}$ )
  - Tokamak divided in **SECTORS** (16 sectors as of BL2017)
  - Breeding Blanket SECTORS divided in Blanket **SEGMENTS**
  - Blanket SEGMENTS divided in **INBOARD** and **OUTBOARD SEGMENTS**
  - Per SECTOR: 2x INBOARD SEGMENTS and 3x OUTBOARD SEGMENTS

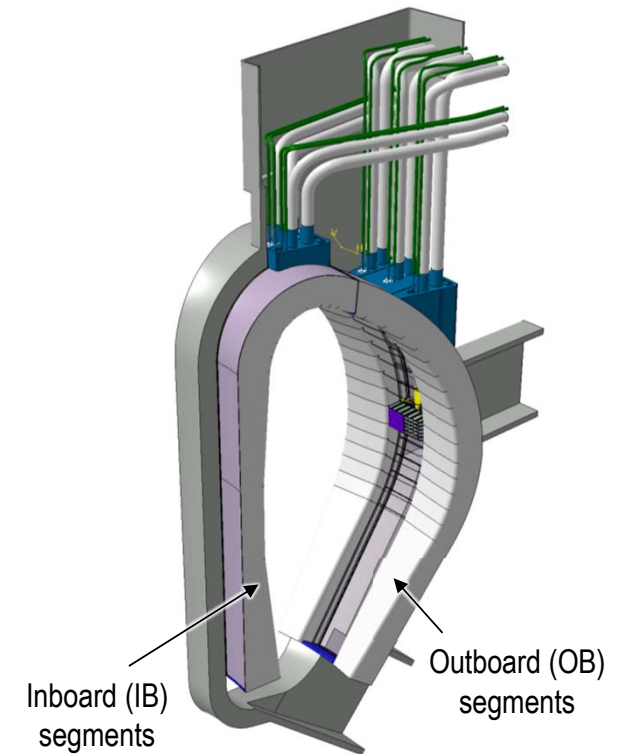
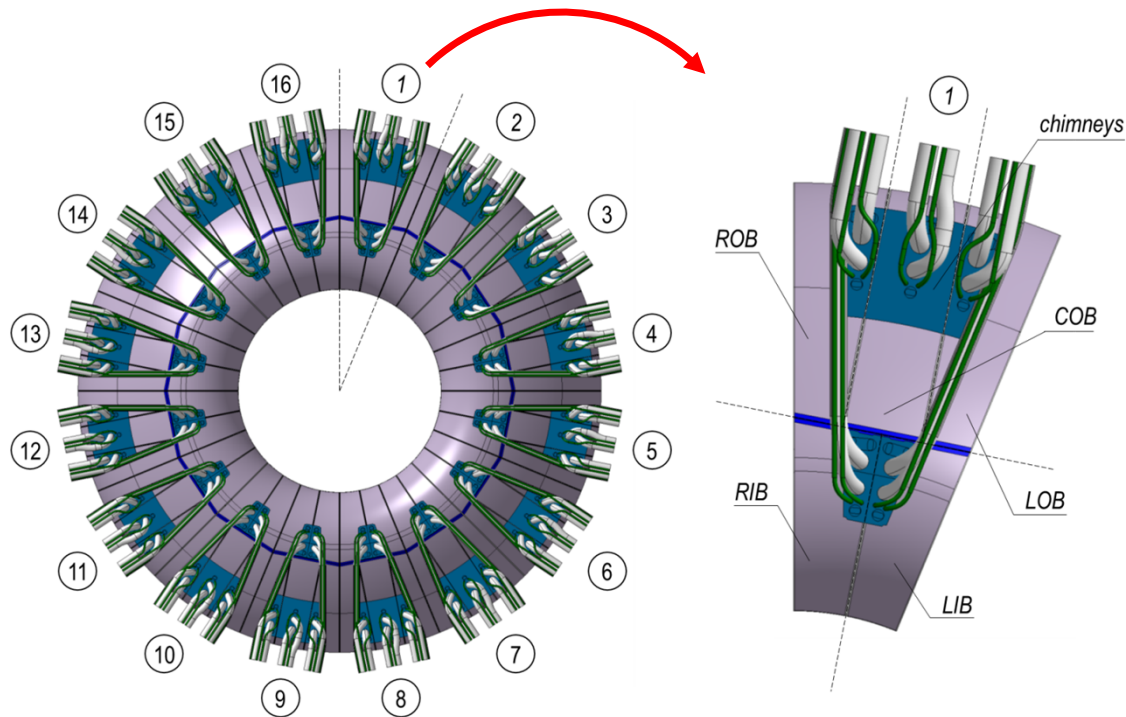

G. Zhou, Status of DEMO HCPB Breeding Blanket in Europe, Fusion Seminar at GCPD e.V., Online, 17 April 2022.



1. Why Breeding Blanket?
2. What is a HCPB?
3. EU-DME0 Top-Level Requirements
4. The current HCPB Breeding Blanket
5. Challenges
6. Conclusions



## 4. The HCPB BB: General Description

- HCPB „fuel-breeder pin“ design (BL2017)

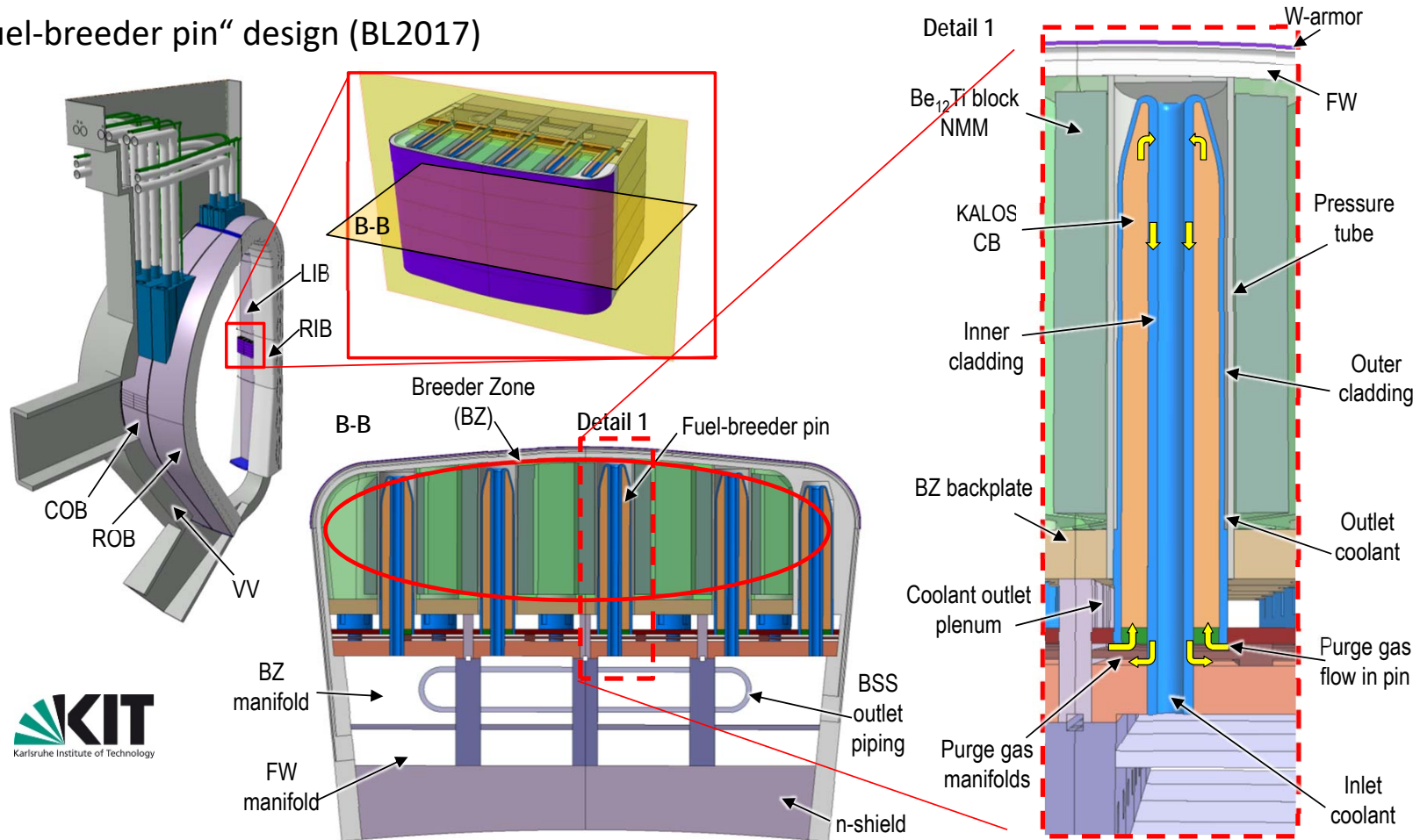

## 4. The HCPB BB: Coolant Scheme

- Coolant thermo-hydraulic parameters:
  - He 80 bar,  $T_{in} = 300^{\circ}\text{C}$  (limited by  $n$ -induced DBTT shift),  $T_{out} = 520^{\circ}\text{C}$  (limited by steel  $S_{creep}$ )
  - FW and BZ connected in series
  - Need for heat transfer enhancement structures in FW and fuel pins

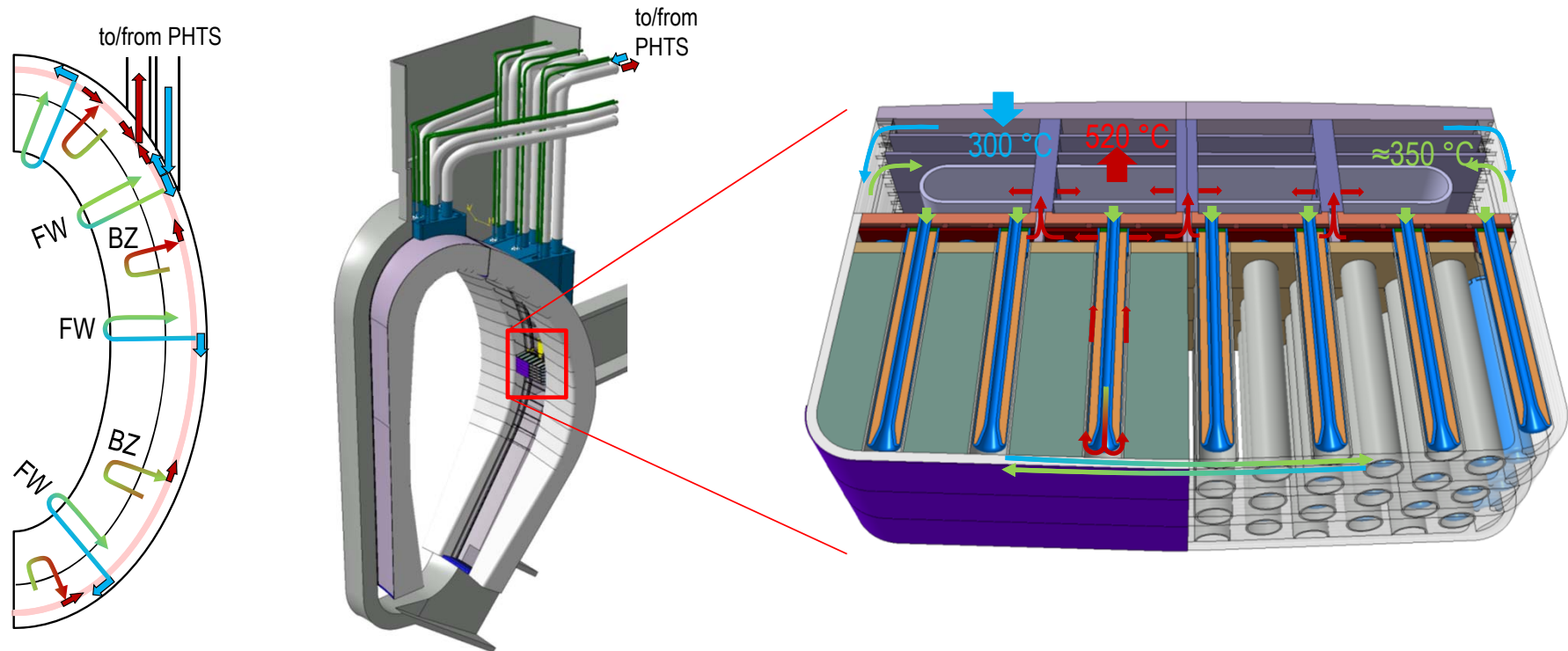

# 4. Design analysis: Performance figures



- Neutronics: nuclear analysis
  - Fully heterogeneous MCNP model
  - Tritium Breeding:
    - ${}^6\text{Li}$  60%:  $\text{TBR}_{\text{design}} \approx 1.20$ ,  ${}^6\text{Li}$  40%:  $\text{TBR}_{\text{design}} \approx 1.16$
  - Neutron shielding:
    - $\text{dpa}_{\text{VV}} \approx 0.130\text{dpa/fpy}$
    - Best shielding materials:  $\text{B}_4\text{C}$ ,  $\text{TiH}_2$ ,  $\text{ZrH}_{1.6}$ ,  $\text{YH}_{1.75}$ ,  $\text{WC}$

## ➤ Detailed local CFD Thermohydraulic analyses:

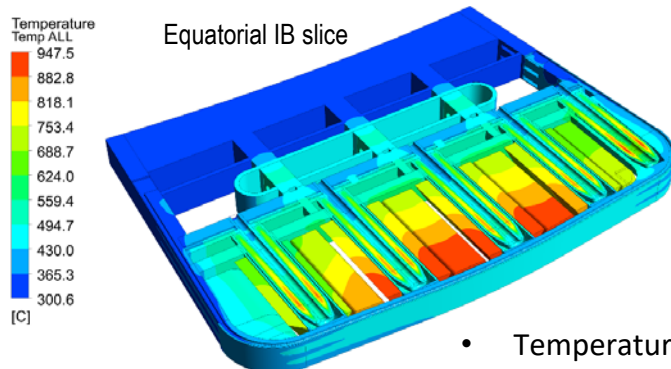

- Temperature limits compliance
- Input for further TM analyses

## ➤ Global FEM & CFD Thermohydraulic analyses:

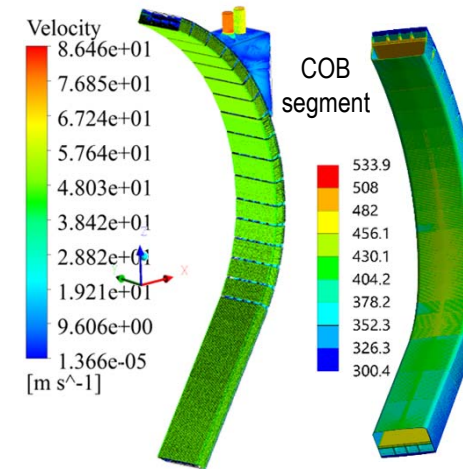

- Input for further TM analyses
- Total BB pressure drops (0.8 bar!)
- Benchmark/calibration of TH models (RELAP5)

## ➤ Detailed local Thermomechanical analyses:

Cat. I (normal operation)

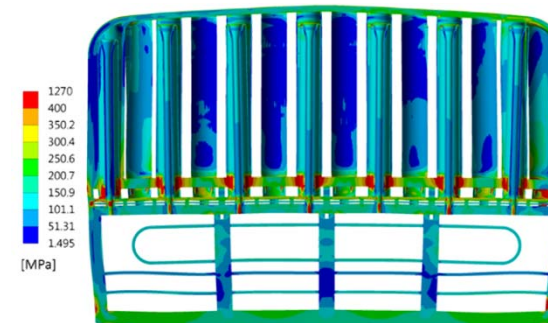

- Evaluation of normal and off-normal (e.g. in-box LOCA) operation
- Compliance with RCC-MRx code



# 4. Design-supporting analyses

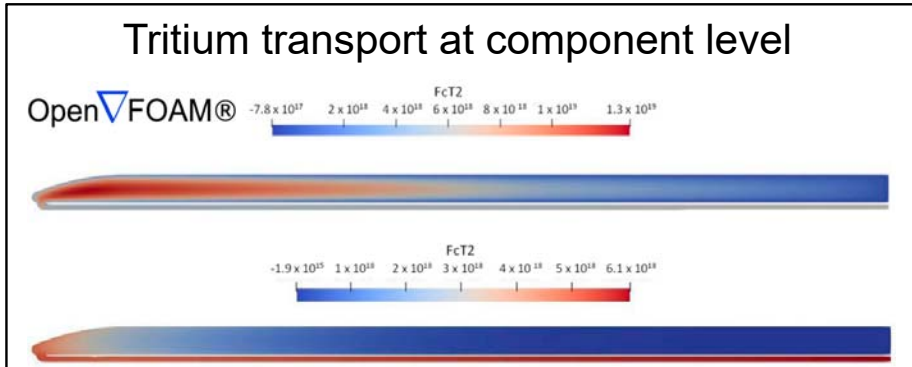
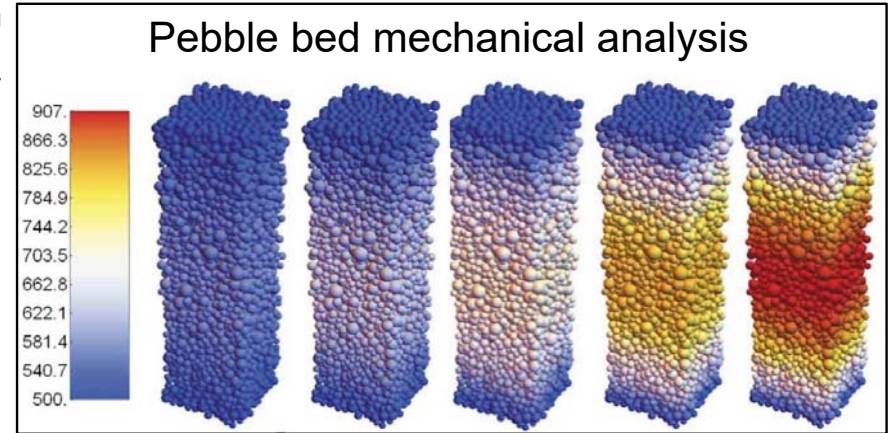
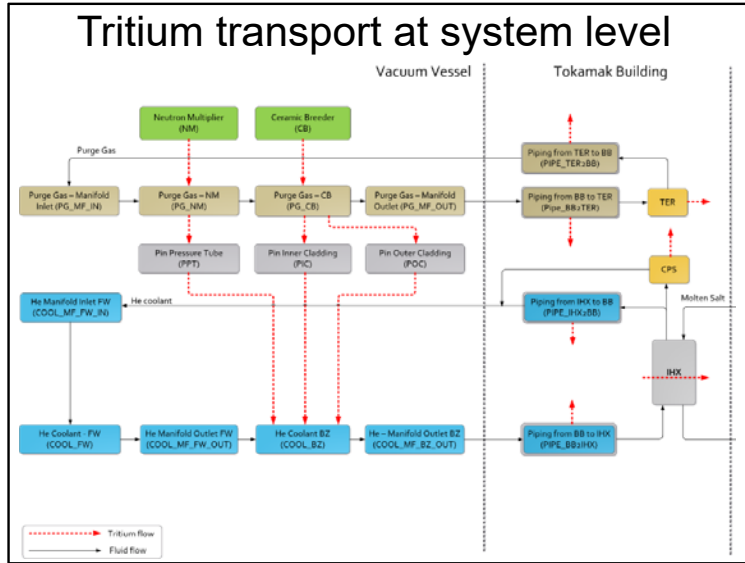

He flow modeling using in-house code

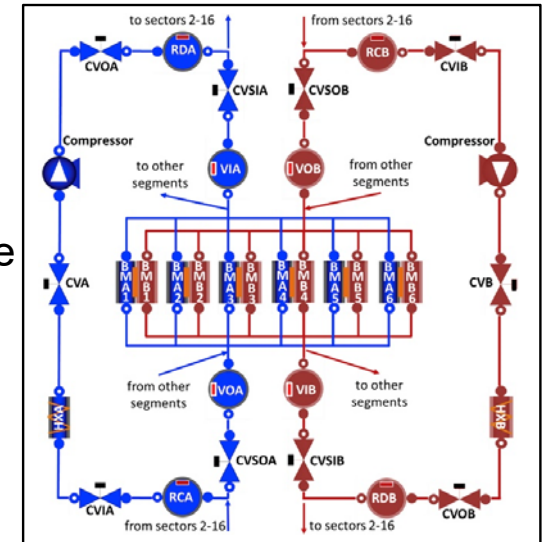

# 4. Technology R&D – Solid breeder development

## Upgrade of KALOS facility

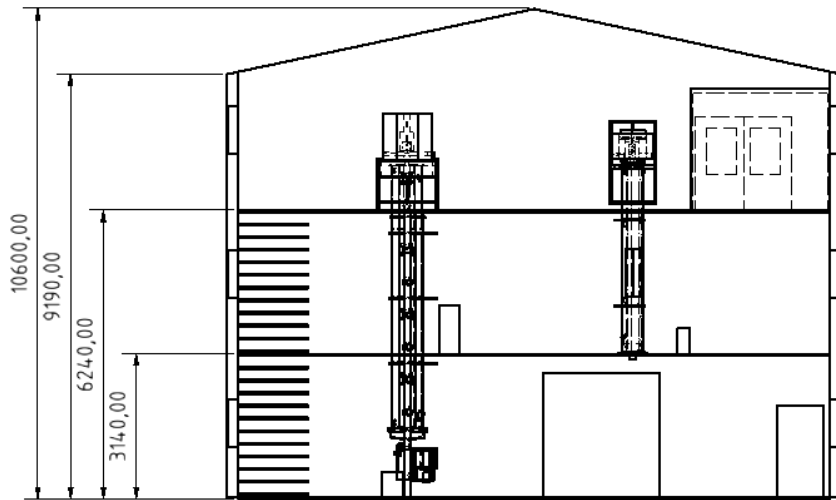

KALOS - KARlsruhe Lithium OrthoSilicate

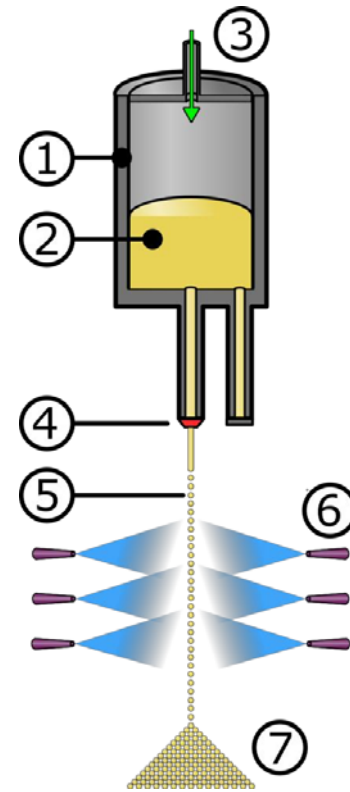

KALOS process schematic

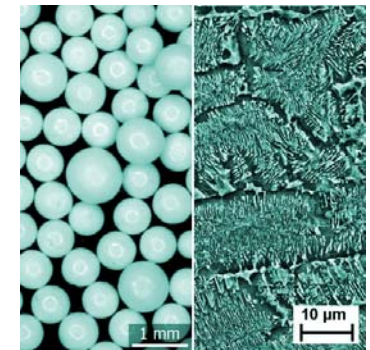

Pebbles characterization

## 4. Technology R&D – Neutron multiplier development

European Commission SOFT Innovation Prize

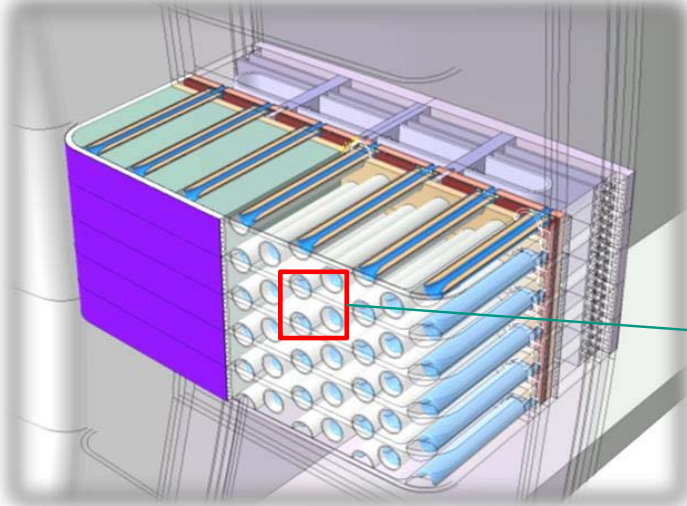

Be12Ti block

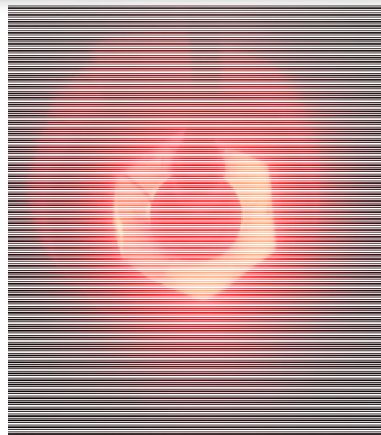

Be12Ti block withstand over 200 thermal cycles.

NEWS | 21 September 2020 | Brussels, Belgium | Research and Innovation

### Fusion research and innovation: three researchers awarded

Today, the European Commission revealed the winners of the 2020 edition of the [SOFT Innovation Prize](#). This prize, awarded at the [31st Symposium on Fusion Technology \(SOFT2020\)](#), gives recognition to outstanding researchers or industries who have found innovative ideas or proposed new solutions in fusion research.

This year's winners of the SOFT Innovation Prize are:

- **Second prize (€25 000): Dr. Pavel Vladimirov, Karlsruher Institut für Technologie (KIT)**, for the development of advanced solid neutron multiplier in support of innovative tritium-breeding blanket design. Future nuclear fusion reactors consuming tritium and deuterium should produce their fuel by themselves. The production of fuel shall be facilitated by neutron multiplier, which is an essential part of tritium-breeding blanket.

Source: [https://ec.europa.eu/info/news/fusion-research-and-innovation-three-researchers-awarded-2020-sep-21\\_en](https://ec.europa.eu/info/news/fusion-research-and-innovation-three-researchers-awarded-2020-sep-21_en)

# 4. Technology R&D – HHF Helium cooling technology

High heat flux up to 1200 kW/m<sup>2</sup>, using ribs to enhance the heat transfer performance  
 Summer heat flux of PV panel @UCSD: ca. 300 W/m<sup>2</sup>, UCSD thesis 2011.

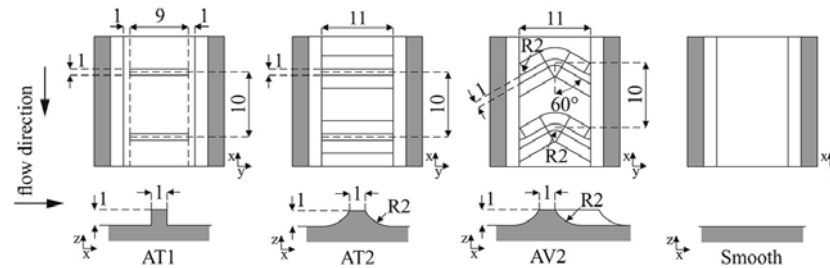
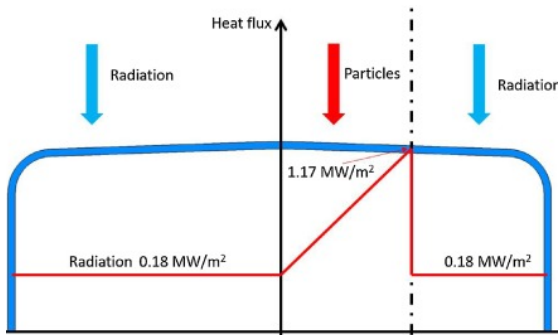

4000 x

Large Eddy Simulation

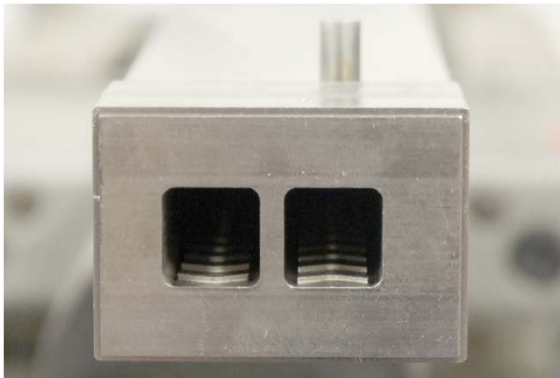
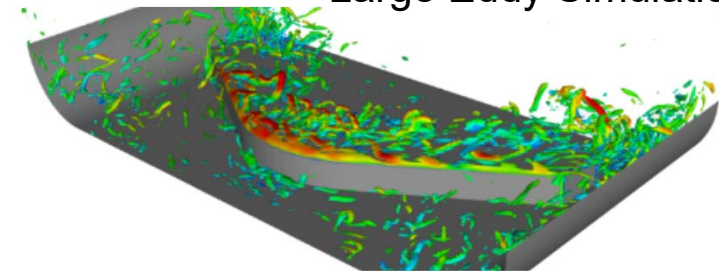

V-rip



High Heat Flux testing



G. Zhou, Status of DEMO HCPB Breeding Blanket in Europe, Fusion Seminar at GCPD e.V., Online, 17 April 2022.

# 4. Technology R&D – FW manufacturing

**Patented technology:** additive manufacturing for manufacturing turbulence promoters.

Charpy-test shows that USE and DBTT comparable

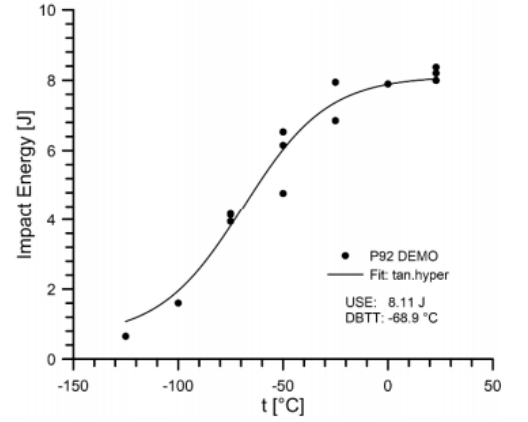
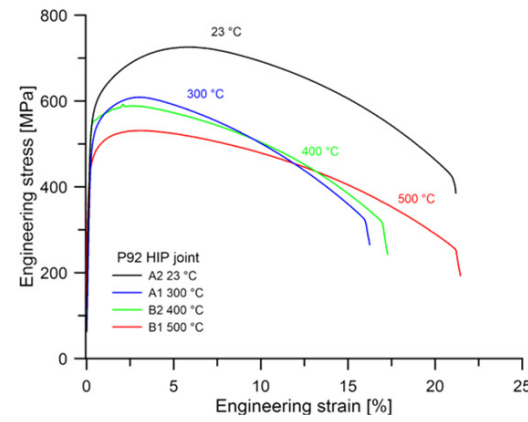
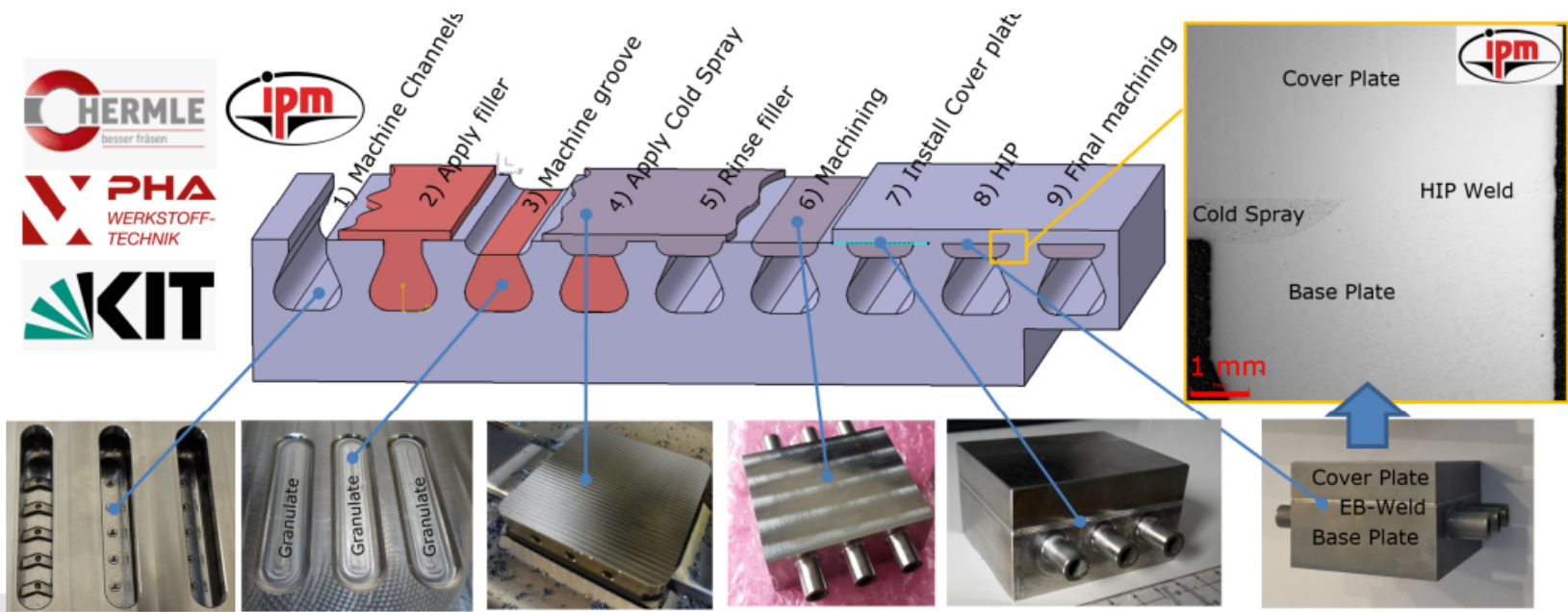

## 4. Technology R&D – FW coating

The coating of the breeding blanket's first wall with a tungsten layer is of key importance for the protection of the TBM and for minimisation of wall erosion.

Thermal expansion mismatch between W and EUROFER can be mitigated with a **functionally graded W/EUROFER interlayer**, manufactured by vacuum plasma spraying.

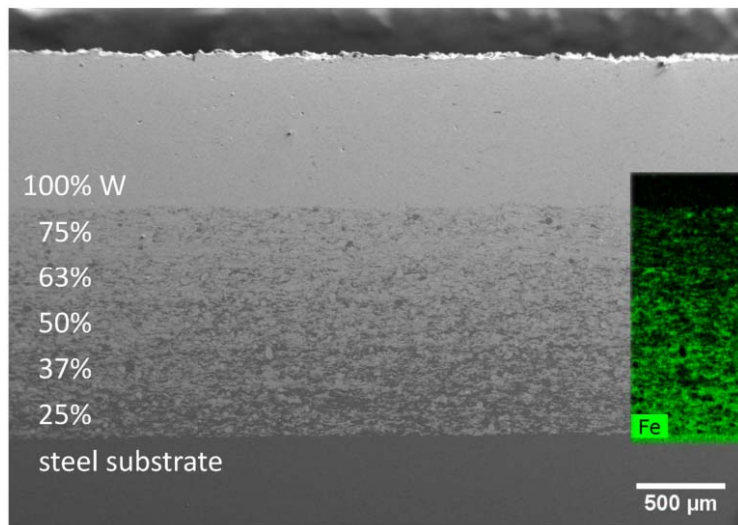

1000 thermal cycles testing

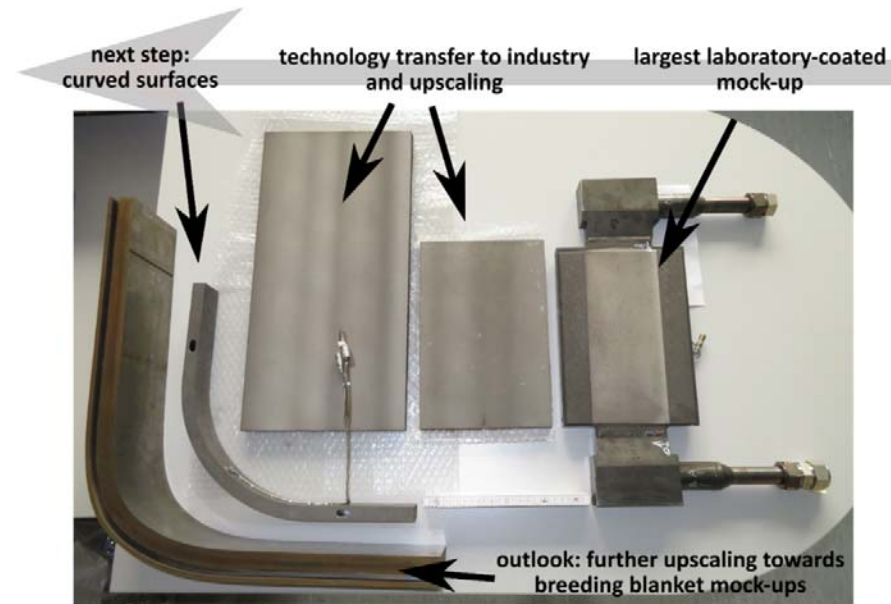

W-coating development: Approaching fusion-relevant size and shape

Coating surfaces  
up to 500×250 mm<sup>2</sup>

# 4. Technology R&D – Prototypical Mock-up testing

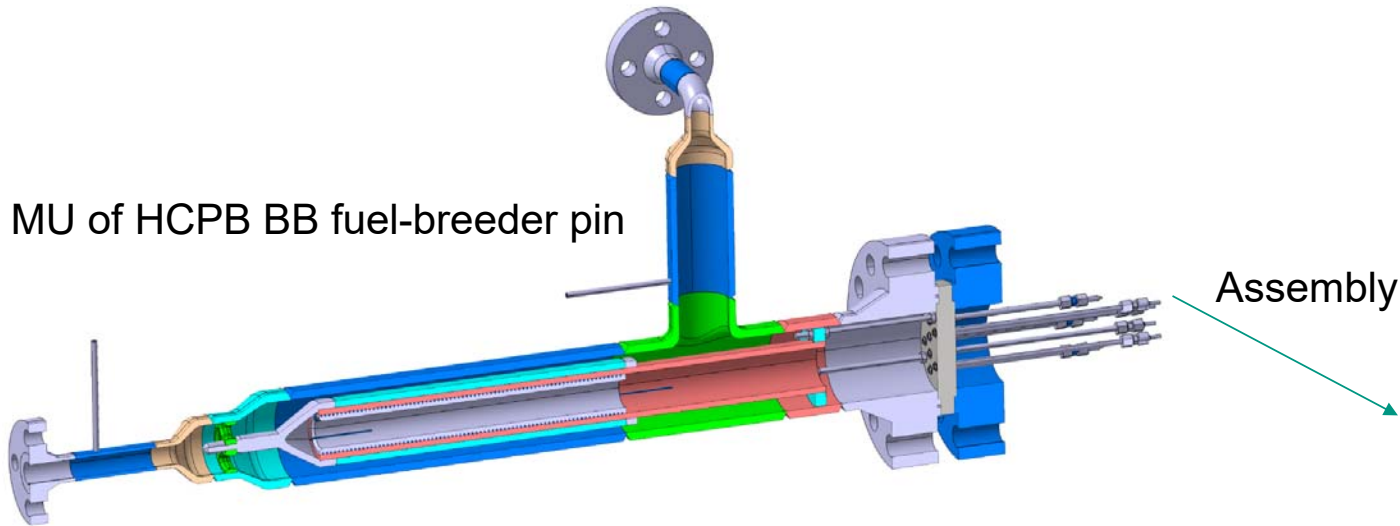

MU of HCPB BB fuel-breeder pin

Assembly



Integration into HELOKA

First test runs completed.



G. Zhou, Status of DEMO HCPB Breeding Blanket in Europe, Fusion Seminar at GCPD e.V., Online, 17 April 2022.



1. Why Breeding Blanket?
2. What is a HCPB?
3. EU-DME0 Top-Level Requirements
4. The current HCPB Breeding Blanket
- 5. Challenges**
6. Conclusions





## 5. Challenges

- Reliability, Availability, Inspectability, Maintainability (RAMI)
  - BB structures very complex (requires a lot of welds) that can fail => reliability ↓
- Limited FW heat flux capability
  - About  $\approx 1-1.5 \text{ MW/m}^2$ , strongest limiting factor: Eurofer-97 steel
- Low reliability of **T** modelling (parameter uncertainties, safety issue)
- **T** permeation into coolant, can lead to safety issue
- Electromagnetic loads, during accidental scenario can be very large (several MN, MNm)
- Strong **n**-induced DBTT shift at  $T < 350^\circ\text{C}$  (steel embrittlement)
- Manufacturing (fabrication and welding tech.) readiness and costs
- $^6\text{Li}$  enrichment level and costs
- Low readiness of the available design Codes and Standards for fusion
  - Implementation of Eurofer-97 into RCC-MRx => multi-decades endeavor, but closing gap
- W-coating technology not yet available for DEMO
  - Some technologies already envisaged, but industrial scale-up to DEMO scale not yet proven



## 6. Conclusions

### ➤ HCPB main characteristics

- Solid breeder (Li ceramic pebbles) and multiplier (Be-alloy blocks): high TBR in compact space
- HTGR-like PHTS (fair TRL), high temperature (higher efficiency, industrial heat)

### ➤ Challenges

- **Common challenges:** RAMI, steel embrittlement, **T** permeation, industrialization and costs
- **Key HCPB-related challenges:** *n*-shielding, thermal control and thermo-mechanics of functional materials, production costs, pressure drops, complex PHTS layout and piping...

Inquiry of self-funded visiting scholars, PhD/PostDoc exchange, Master's students and CSC-funded PhD positions are welcome.

Preferred background: Mechanical Engineering

✉ [Guangming.Zhou@kit.edu](mailto:Guangming.Zhou@kit.edu)

Website: [www.inr.kit.edu](http://www.inr.kit.edu)



# Acknowledgements



This work has been carried out within the framework of the EUROfusion Consortium, funded by the European Union via the Euratom Research and Training Programme (Grant Agreement No 101052200 — EUROfusion). Views and opinions expressed are however those of the author(s) only and do not necessarily reflect those of the European Union or the European Commission.

This work is also funded by the Fusion Programme of the Helmholtz Association of German Research Centres.



**HELMHOLTZ**  
RESEARCH FOR GRAND CHALLENGES

HCPB BB Team:



**Ciemat**



Centrum výzkumu Řež s.r.o.  
Research Centre Řež



**Politecnico di Torino**



**ESTEYCO**