

Research project EMOS: Development of a mobile, automated, optical inspection system for radioactive drums

Sponsored by: *Federal Ministry of Education and Research - FORKA – Research for the dismantling of nuclear facilities*

Sponsoring number **BMBF**: 15S9420, **Timeframe**: 01.01.2020 – 31.12.2022

Starting position

- Due to delays in the construction and commissioning of a German repository for medium and low level radioactive waste, waste stocks from several decades are now at the interim storage locations.
- The safe storage of these waste packages must be guaranteed for an indefinite period of interim storage.
- The usual practice in interim storage facilities is recurring inspections of the drums, which are almost exclusively carried out manually, without electronic comparison recordings and without machine documentation and archiving.
- The visual tests are highly subjective and therefore also prone to errors; In addition, the manual implementation is labor-intensive and the personnel is exposed to radiation.

20 ft High Cube Container with a rolling gate at the long side

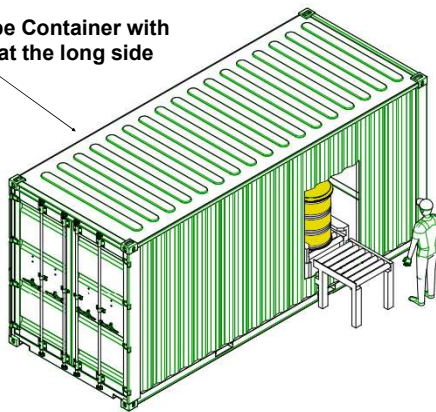

Goal of the research project

- Development and conception of a mobile inspection unit that remotely and automatically handles and evaluates the entire drum surface, including lid and bottom, optically and analytically.
- Detection of geometry and corrosion damage to the drum at an early stage.
- Facilitation of the optical monitoring of the stored drums.
- Increase in occupational safety and optimization of recurring tests through standardization and reproducibility.

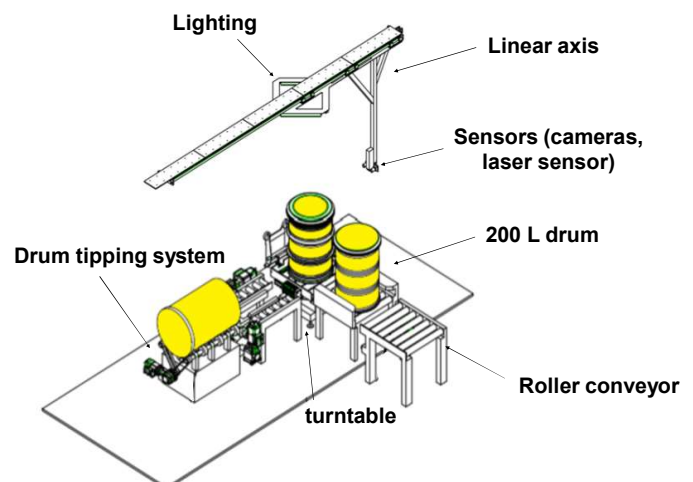

Project shares of the Cooperation partners

- Institute of Technology and Management in Construction (**TMB**) – development, conception and construction of the inspection unit
- Institute of Photogrammetry und Remote Sensing (**IPF**) – selection and conception of the optical acquisition, as well as creation and implementation of the evaluation algorithms



Drum on turntable



Drum on tipping system

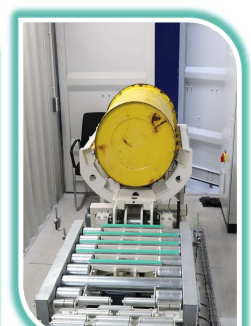

Drum bottom

Karlsruhe Institute of Technology (KIT)

Institute of Technology und Management in Construction (TMB)

Prof. Dr.- Ing. Sascha Gentes, phone: +49 721 608-46546, E-Mail: sascha.gentes@kit.edu

M.Sc. Tania Barretto , phone: +49 721 608-44121, E-Mail: tania.barretto@kit.edu

M.Eng. Eric Rentschler, phone: +49 721 608-44121, E-Mail: eric.rentschler@kit.edu

Dipl.-Ing. Melanie Müßle, phone: +49 721 608-42398, E-Mail: melanie.muessle@kit.edu