

Received XX Month, XXXX; revised XX Month, XXXX; accepted XX Month, XXXX; Date of publication XX Month, XXXX; date of current version XX Month, XXXX.

Digital Object Identifier 10.1109/OJPEL.2022.0817315

A Comprehensive Review on DC Fast Charging Stations for Electric Vehicles: Standards, Power Conversion Technologies, Architectures, Energy Management, and Cybersecurity

GABRIELE ARENA* (GRADUATE STUDENT MEMBER, IEEE), ANDRII CHUB† (SENIOR MEMBER, IEEE), MYKOLA LUKIANOV‡, RYSZARD STRZELECKI‡ (SENIOR MEMBER, IEEE), DMITRI VINNIKOV† (FELLOW, IEEE), AND GIOVANNI DE CARNE* (SENIOR MEMBER, IEEE)

¹Institute for Technical Physics (ITEP), Karlsruhe Institute of Technology (KIT), Karlsruhe, Germany

²Power Electronics Research Group, Tallinn University of Technology (TalTech), Tallinn, Estonia

³Faculty of Electrical and Control Engineering, Gdańsk University of Technology, Gdańsk, Poland

CORRESPONDING AUTHOR: GIOVANNI DE CARNE (e-mail: giovanni.carne@kit.edu).

This project has received funding from the European Union's Framework Programme for Research and Innovation, Horizon 2020 (2014-2020), under the Marie Skłodowska-Curie Grant Agreement No. 955614. This research was also supported by the Estonian Research Council (grant PRG2055) and by the Estonian Centre of Excellence in Energy Efficiency, ENER, funded by the Estonian Ministry of Education and Research under Grant TK230. The work of Giovanni De Carne was supported by the Helmholtz Association within the Helmholtz Young Investigator Group "Hybrid Networks" (VH-NG-1613).

ABSTRACT This paper aims to review the main research points regarding DC fast charging stations. At the beginning, the paper addresses an overview of DC fast charging standards, galvanic isolation, EV powertrain, and some examples of real DC fast chargers. This part highlights that DC fast chargers are usually connected to an AC network or microgrid, whereas DC microgrids would be a better choice to increase the charging efficiency and reduce the costs. However, the lack of standards in terms of protection and metering made their spread limited for the moment. Moreover, the paper describes the power converter topologies typically adopted in DC fast charging stations and emerging solutions to interface EVs with both 400 V and 800 V powertrains. Then, the paper explains the main architectural features of DC fast charging stations connected to DC networks or microgrids because of their potential to become the standard infrastructure in this field. Furthermore, the energy management strategies for DC fast charging stations are discussed, taking into account their relevant goals. Finally, cybersecurity issues of charging stations are covered, also considering their impact on grid and electric vehicle supply equipment, and providing a particular discussion regarding DC fast charging stations.

INDEX TERMS Electric vehicles, DC fast charging stations, power converters, energy management, cybersecurity.

I. INTRODUCTION

ELECTRIC vehicles (EVs) have known significant growth over the years and are one of the solutions leading towards the green energy transition. EV registrations increase every year, in particular in China, Europe, and the

USA, as shown in Fig. 1 [1]. However, one of the main issues affecting EV sales is range anxiety in comparison to the higher autonomy of traditional internal combustion engine vehicles (ICEVs). One way to address this issue is to improve battery technology, and many research works

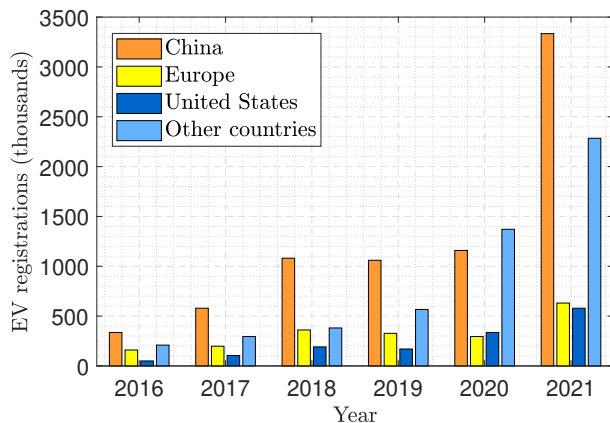

FIGURE 1: EV registrations in the period 2016-2021 [1].

focus on this topic. For example, the methods to improve the cathode performance in lithium-ion batteries (LIBs) for EV applications are reviewed in [2]. Moreover, the limitations of LIBs when charging at a high current rate and the consequent battery degradation are addressed in [3]. Furthermore, the thermal management of LIBs based on forced air is discussed in [4]. However, LIBs also have an environmental impact that must concern governments, manufacturers, and scientists [5]. Recycling LIBs is a practical way to decrease their environmental impact [6].

Another way to address the range anxiety issue is to develop a wide fast charging infrastructure that allows EV owners to recharge their EVs in a short time range, comparable to the refueling time of ICEVs. For example, Tesla superchargers allow to add up to 300 km in 15 minutes [7]. DC fast charger distribution increased more or less with the same speed as EV registrations, as shown in Fig. 2a [1], [8]. Moreover, Fig. 2b shows that China is the leading country by the number of EV chargers [8]. However, planning the charging infrastructure taking into account the limitations of the power distribution networks is one of the main challenges that electricity distributors have to face in the coming years [9].

Various reviews addressed different DC fast charging aspects. International standards and main architectural features of EV charging were dealt with in [10] and [11]. The main power converters adopted in DC fast charging stations and their related control methods were addressed in [12]. Some examples of real chargers and their power converter topologies were shown in [13]. MV extreme fast charging power conversion technology based on the solid-state transformer (SST) was addressed in [14]–[16]. The grid impact of DC fast charging stations was examined in [17]. Energy storage systems for DC fast charging stations were discussed in [18]. Even though these reviews covered numerous power converters adopted in DC fast charging stations and are milestones in this field, the arrival of new EV models with 800 V powertrains on the market creates the need for low-

cost single-stage DC-DC converter topologies capable of interfacing both the traditional 400 V and the new 800 V powertrains. Moreover, since DC fast charging stations connected to DC networks and DC microgrids are expected to be dominant in the future due to the higher efficiency, fewer power converters needed, and reduced costs compared to a traditional AC network, the given paper aims to give a detailed explanation of their main architectural features. In recent years, some manufacturers of power electronic converters have been proposing to use 400 V/800 V interface converters as a temporary solution to fix compatibility issues between the existing charging infrastructure and forthcoming EVs [19]. Hence, the industry requires universal and low-cost power electronic solutions enabling future-proof EV charging infrastructure.

Furthermore, various reviews have also addressed energy management and related topics of EV charging stations. A review on vehicle-to-everything (V2X) technologies was addressed in [21] and the energy management strategies in vehicle-to-grid (V2G) with integrated renewable energy sources (RESs) were reviewed in [22]. A review of energy management strategies for EV charging stations was also given in [23]. Even though these reviews give a good perspective of energy management issues in EV charging stations, they do not specifically address energy management strategies for DC fast charging stations. This research gap is covered in the given paper.

Finally, this paper also reviews the main cybersecurity issues in DC fast charging stations. This point is usually not connected to the standards, infrastructure, and power conversion technology of DC fast charging stations, but it was added to give a complete perspective of the challenges regarding DC fast charging stations, where communication infrastructure and associated cybersecurity measures are inseparable parts of the whole system.

The main contributions of this review paper are stated as follows to highlight the difference with the previous reviews in the same field:

- 1) This paper reviewed the standards of DC fast charging stations, taking into account new updates and emerging standards, such as the MW charging system, omitted in the previous reviews. Moreover, the differences between the new 800 V EVs and the traditional 400 V EVs have been explained. Yet, examples of real chargers have been provided, also taking into account new charging solutions based on a common DC-bus.
- 2) The main converter topologies adopted in DC fast charging stations have been reviewed. Moreover, emerging converter topologies that were not addressed in previous reviews have been covered to demonstrate universal single-stage charging solutions compatible with both traditional 400 V EVs and emerged 800 V EVs.
- 3) The main architectural features of DC fast charging stations with common DC-bus and located inside DC

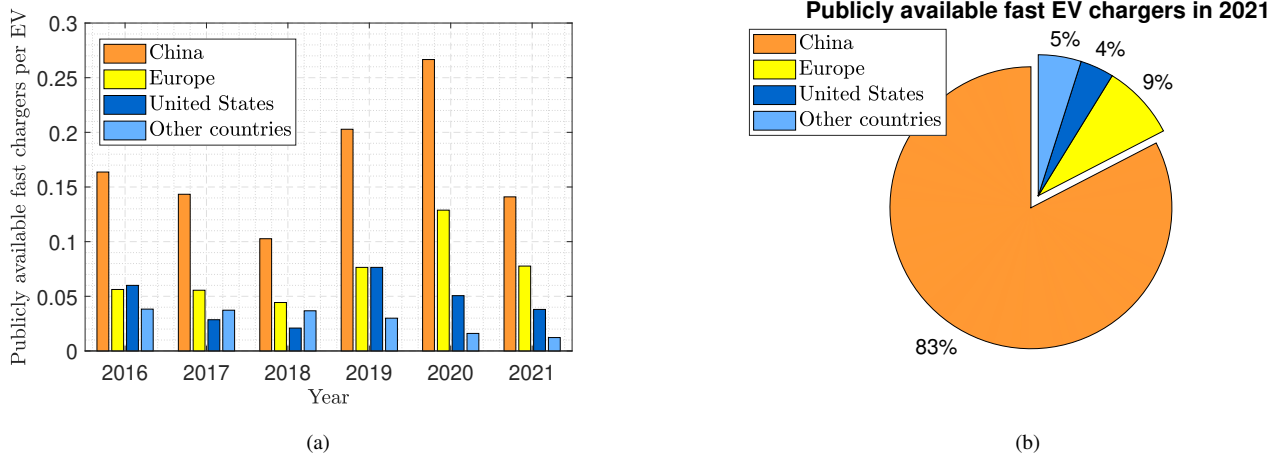

FIGURE 2: Fast chargers availability. (a) Fast chargers per EV available in different regions in the years 2016-2021 [1], [8]. (b) Breakdown of publicly available EV fast chargers in 2021 [8].

TABLE 1: Comparison of research topics addressed in review papers on DC fast charging stations

Research work	Standards	Power converters	Universal DC-DC converters for 400 V and 800 V batteries	Architectures	Energy management	Cybersecurity	Year
[12]	✓	✓	×	×	×	×	2022
[14]	✓	✓	×	×	×	×	2019
[16]	✓	✓	×	×	×	×	2022
[17]	✓	✓	×	×	✓	×	2021
[18]	×	✓	×	✓	✓	×	2020
[20]	✓	✓	×	×	×	×	2022
This work	✓	✓	✓	✓	✓	✓	2024







networks or microgrids have been discussed with examples of real chargers and patented solutions. Moreover, MW charging has been covered, taking into account architecture and issues. Safety, protection, and isolation requirements have also been addressed. Yet, the integration of battery energy storage systems (BESSs) into DC-connection fast charging stations and the case study of the integration of DC fast chargers into traction grids have been discussed.

- 4) The energy management strategies adopted in DC fast charging stations have been reviewed and classified based on their goals and their optimization approaches.
- 5) Cybersecurity issues related to EV charging and DC fast charging stations have been reviewed, and their impact on the power grid, charging station, and power converters have been addressed

In order to highlight the differences with respect to the current state of the art on DC fast charging stations, the different topics addressed in the given work have been compared to other review papers as shown in Table 1. The importance of the prior review papers cannot be overstated,

but the fast pace at which this topic develops warrants regular updates on the state of the art, including topics like cybersecurity that were not considered till recently. As can be observed from the table, this study provides a unique combination of topics that reflect the latest advancements in DC fast charging stations and their implementation issues. In particular, this paper addresses new standards available on the market, such as ChaoJi and MW charging. Moreover, tailored power converter solutions to interface both 400 V and 800 V based-EVs are reviewed for the first time in this research work. Such converters are really important to keep high conversion efficiency when charging EVs with different battery voltages, ideally from 200 V to 1000 V to interface old, new, and coming technologies. DC fast charging architectures based on DC microgrids have been reviewed for the first time as well, also including the integration into traction grids and MW charging stations. Several new energy management works specifically intended for DC fast charging stations have also been reviewed in a comprehensive way to highlight the importance of optimization strategies in the charging infrastructure. Furthermore, cybersecurity for DC

TABLE 2: Standards for DC Fast Charging Stations [13], [14], [17], [24]

Standards	CHAdeMO	GB/T	CCS Type 1	CCS Type 2	ChaoJi	NACS	MCS
Output voltage	50-1000 V	250-950 V	200-1000 V	200-1000 V	1000-1500 V	300-480 V	500-1250 V
Maximum current	400 A	250 A	400 A	400 A	600 A	800 A	3000 A
Maximum power	400 kW	237.5 kW	200 kW	350 kW	900 kW	250 kW	3.75 MW
Communication protocol	CAN*	CAN	PLC†	PLC	CAN	CAN	PLC
V2X capability	Yes	No	No	No	Yes	No	Yes
Compliant standards	IEEE2030.1.1 IEC 62196-3	IEC 62196-3	SAE J1772 IEC 62196-3	IEC 62196-3	CHAdeMO GB/T	IEC 62196-3	IEC 62196-3 IEC 61851-23
Region	Worldwide	China India	United States South Korea	Europe Australia	Worldwide	Worldwide	Worldwide
Connector							

* CAN: controller area network.
† PLC: power line communication.

fast charging stations has been discussed for the first time, detailing the cyber attacks and the approaches to deal with them, as well as analyzing their impact on the charging and electrical infrastructure. The research works linking the electrical layer and the cyber layer of the DC fast charging stations have been reviewed in this paper for the first time.

This paper is divided into the following sections. Section II gives an overview of DC fast charging standards, implications related to galvanic isolation, EV powertrains currently available on the market, and commercial EV fast chargers. Section III reviews the power converter topologies adopted in DC fast charging stations connected to the LV grid and to the MV grid and emerging converter topologies to create a universal interface for 400 V and 800 V EVs. Section IV explains the main architectural features of DC fast charging stations based on a DC network or microgrid. Section V discusses energy management strategies adopted in DC fast charging stations. Finally, section VI introduces the main cybersecurity issues of charging stations in general, also providing a discussion focused on DC fast charging stations.

II. OVERVIEW OF DC FAST CHARGING SYSTEMS

This section explains the main features of DC fast chargers. In particular, charging levels are categorized into classes to explain why DC fast charging is needed and what the difference is with the other types of charging methods for EVs. Then, a comparison between 400 V and 800 V EV architecture will follow to understand which kind of EVs are currently available on the market and how their architecture can affect the development of DC fast charging stations. Finally, examples of commercial fast chargers currently available on the market will be discussed to give a real perspective of such a technology.

A. CHARGING STANDARDS

The charging standards for EV charging can be first divided into AC and DC charging. AC charging standards are usually associated with slow charging and are characterized by the presence of on-board battery chargers [11]. The SAE J1772 standard is the one used in the United States, Japan, and South Korea, and it has a maximum power of 1.9 kW in level 1 and 19.2 kW in level 2. The IEC 61851 is the charging standard used in Europe and Australia, and it has a maximum power of 13.3 kW in mode 1 and 22 kW in modes 2-3. GB/T is the AC charging standard used in China and India. It provides a maximum power transfer of 12.8 kW. In November 2022, Tesla opened its charging standard, and it is now called the North American Charging Standard (NACS) [25]. In AC charging, NACS provides a maximum of 7.7 kW for mobile connection and 20 kW for wall connection [13], [26], [27].

DC fast charging is instead associated with off-board battery charging because the power provided by an off-board charger is too high to be delivered through an on-board charger, and it would occupy too much space inside the EV [11]. The first widely-adopted DC charging standard is CHAdeMO, a standard spread globally, which offers a maximum power of 400 kW and an output voltage from 50 to 1000 V. CCS type 1 and type 2 offer both 350 kW maximum power and from 200 V to 1000 V output voltage. The first one is used in the United States and South Korea, whereas the second one is used in Europe and Australia. GB/T is adopted in China and India and offers a maximum charging power of 237.5 kW with an output voltage from 250 to 950 V. NACS offers a maximum charging power of 350 kW with an output voltage from 300 to 480 V, which then is not adequate for 800 V drivetrain [13], [14], [26]. CHAoJi is a new standard born from the collaboration between the

CHAdeMO and GB/T standards with the aim of further increasing the charging power of DC fast chargers. It offers a maximum charging power of 900 kW and a maximum output voltage of 1500 V [17], [24], [26]. Finally, the megawatt charging system (MCS) was proposed by CharIN to be considered by standards development organizations in 2018. It is rated for up to 3.75 MW of charging power with an output voltage of 500-1250 V and an output current of 3000 A [28]. Even though such a standard offers a very high charging rate, its output voltage is not meant for traditional 400 V EVs, and so, it cannot be considered a universal solution for light-duty (LD) and heavy-duty electric vehicles (HD-EVs). A harmonized universal standard for LD-EVs and HD-EVs is currently missing, which could potentially lead to copativity issues in charging infrastructure for EV owners and companies. The specifications of the existing standards are summarized in Table 2.

It is worth mentioning that the dropping popularity of CHAdeMO charging stations leaves a gap in the market of V2G solutions. Rapidly proliferating CCS charging standard does not provide market-ready V2G DC-connected solutions yet. On one side, DIN 70121 communication protocol currently used in CCS EV chargers does not fully correspond to the needs of the V2G market. On the other hand, the existing powerline communication hardware implemented in the CCS chargers is compatible with the latest updates to the ISO 15118-20 communication interface. A simple software update would enable the next generation of communication and control features along with updated cybersecurity. The current roadmap of the CCS 2.0 standard development by CharIN e.V. states that aggregated level-4 V2G bidirectional charging will be specified around 2025 based on the ISO 15118-20 [29]. On the positive side, many of the deployed CCS chargers are V2G-ready and, with updated software, would be able to implement the forthcoming additions to the standard.

B. EV POWERTRAIN: 400 V VS. 800 V

In order to understand the advancements in the DC fast charging technology, it is important to understand what are the typical bus voltages adopted in an EV powertrain and how they affect the maximum allowed charging power of an EV. EV manufacturers have traditionally adopted 400 V buses in the powertrains of their vehicles. However, companies are now considering adopting the 800 V architecture because this allows them to reduce the charging current, decrease the cabling size, and reduce the overall weight of the EVs. Another important advantage is that the 800 V architecture would enable an increased charging power for EVs, making the charging duration comparable to the refueling of ICEVs. However, a first disadvantage of the 800 V architecture is that the battery needs to have twice the number of cells connected in series, which leads to a more complex battery management system (BMS) architecture and increased costs. Moreover, the inverters that are usually used

TABLE 3: Examples of EVs available on the market

Manufacturer & Model	Battery capacity*	Max charg. power	Architecture
Tesla Model Y Long Range	75 kWh	250 kW	400 V
Tesla Model 3 Long Range	75 kWh	250 kW	400 V
Nissan Leaf	39 kWh	50 kW	400 V
Fiat 500e Long Range	37.3 kWh	85 kW	400 V
Volkswagen ID.4	77 kWh	135 kW	400 V
Porsche Taycan	82.3 kWh	320 kW	800 V
Audi e-tron GT	85 kWh	268 kW	800 V
Hyundai IONIQ 5	74 kWh	350 kW	800 V
Kia EV6 Long Range AWD	74 kWh	350 kW	800 V

* Referred as the useable battery capacity of the EV.

in EVs are made of 600 V IGBTs, whereas the 800 V architecture would require 1200 V MOSFETs or IGBTs, which in turn increases the costs of the system as well [30], [31].

Another problem raised from this development is the compatibility of EV chargers with different types of powertrain architecture. EVs with the 800 V architecture are usually equipped with an onboard DC-DC converter to interface chargers that were developed for a 400 V architecture. In this sense, the lack of a common architecture can cause a decreased charging efficiency and force manufacturers to increase the costs of EV chargers to make them compatible with different powertrain architectures. As it is possible to see from Table 3, the 800 V architecture effectively enables high power charging rates. Several manufacturers have been able to reach charging speeds of 350 kW, uncovering the full potential of the 800 V powertrains [30]. On the other hand, the Tesla Model Y Long Range and Tesla Model 3 Long Range are two examples employing the 400 V architecture with a power charging rate comparable to that of the 800 V architecture.

C. CURRENT DEVELOPMENTS IN EV FAST CHARGERS

DC fast charging stations can be connected to an AC network/microgrid or to a DC network/microgrid. Consequently, the fast charging stations could be referred to as AC-connected and DC-connected to highlight this difference [26]. AC-connected fast charging stations are more adopted than DC-connected ones because they provide reliable protection and metering standards. However, they require a DC-DC conversion stage per each charger, which means an increase in cost and a decrease in efficiency. On the other side, DC-connected fast charging stations require only one rectification stage interfacing the grid, which decreases costs and improves efficiency. However, DC-connected fast charging stations, and more in general low voltage DC networks and microgrids, lack protection and metering standards, which is the reason why AC-connected fast charging stations

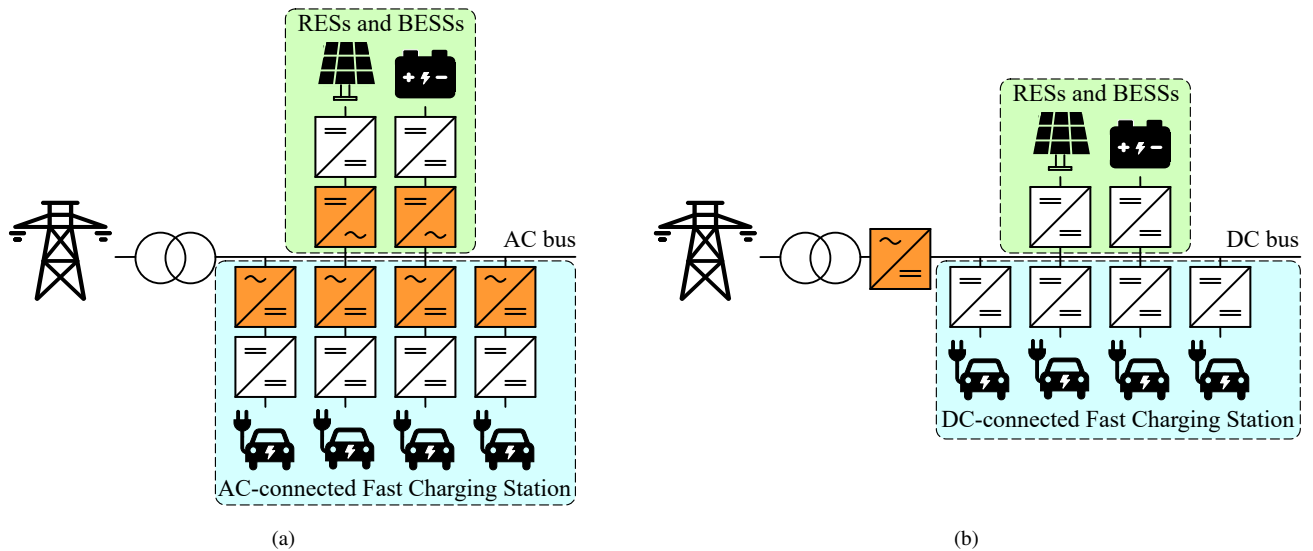

FIGURE 3: DC fast charging systems. (a) AC-connected fast charging station. (b) DC-connected fast charging station [26].

TABLE 4: Examples of AC-connected and DC-connected Fast Charging Stations Available in the Market [11], [14]

Manufacturer & Model	AC-connected fast chargers			DC-connected fast chargers	
	ABB Terra 124 [32]	PHIHONG CE, DS 150 Series [33]	Tritium PKM150 [34]	Tritium NEVI System [35]	Enercon E-charger 600 [36], [37]
Power	120 kW or 60 kW x 2	150 kW	150 kW or 75 kW x 2	150 kW or 75 kW x 2	600 kW total 1 to 4 charging points up to 350 kW per charging point
Supported protocols	CCS Type 1 CHAdeMO 1.2	CCS Type 2 CHAdeMO 1.2 GB/T	CCS Type 1 CHAdeMO	CCS Type 1 CHAdeMO NACS	CHAdeMO
Input voltage	LVAC 3 phase	LVAC 3 phase	LVAC 3 phase	LVAC 3 phase	LVAC 3 phase
DC bus	N.A.*	N.A.	950 V _{dc}	950 V _{dc}	720 V _{dc}
Output DC voltage	150 – 920 V _{dc}	500 – 950 V _{dc}	150 – 920 V _{dc}	-	200 to 920 V _{dc}
Output DC current	200 A _{dc}	120 – 200 A _{dc}	350 A _{dc}	-	-
Peak efficiency	95 %	≥ 94 %	> 97 %	-	94 %

* N.A.: not applicable.

are currently more common [11], [14]. AC-connected and DC-connected fast charging systems are shown in Figs. 3a and 3b, respectively. Several examples of the commercial AC-connected and DC-connected fast EV chargers are given in Table 4.

An example of the higher efficiency of DC-connected fast charging stations was given in [26], where the Tritium PKM150 is shown to have an efficiency of 97 % [34]. On the other side, the PHIHONG 150 Series is an AC-connected charger with an efficiency of about 94 % [33]. This example shows the potential of DC-connected fast charging stations as the fast charging solution of the future, making DC-connected fast charging stations the main focus of this paper.

Also, they allow for straightforward integration of on-site renewable energy generation and energy storage systems and enable their grid-interactive operation.

III. POWER CONVERTERS FOR DC FAST CHARGING STATIONS

The choice of converter topology for fast charging stations is extremely important, as it directly determines the applicability of the charging station in each specific case. In particular, selecting both the AC-DC stage when connecting to AC grids and the DC-DC stage when connecting directly to DC grids is crucial. For this reason, this section aims to review the most common AC-DC and DC-DC converters used in DC fast charging applications. Moreover, this section analyzes

TABLE 5: Comparison of AC-DC converter topologies

Power Converter	Switches/ diodes	Capacitors/ Inductors	Pros	Cons
Three-phase PWM rectifier	6/6	1/1	Unity power factor, low THD.	Non suitable for bipolar architectures.
NPC converter	12/18	1/2	Unity power factor, very low THD, possibility of bipolar architecture, and less stress on the switching devices.	Extra balancing circuitry or more complex control techniques are needed to balance the bipolar DC bus.
Vienna rectifier	6/12	1/2	High power density, unity power factor, very low THD, possibility of bipolar architecture, and less stress on the switching devices.	Unidirectional topology. Extra balancing circuitry or more complex control techniques are needed to balance the bipolar DC bus.
T-type converter	12/12	1/2	Unity power factor, very low THD, possibility of bipolar architecture, and less stress on the switching devices.	Extra balancing circuitry or more complex control techniques are needed to balance the bipolar DC bus.

the converter solutions that are adopted in MV applications. Then, emerging solutions proposed in literature or patented by companies will also be discussed.

A. AC-DC CONVERTERS

The three-phase PWM rectifier is a bidirectional topology made of three switching legs, each of them with two IGBTs or MOSFETs, and antiparallel diodes. This topology can be used to reach the power factor of one and low total harmonic distortion (THD), thanks to its high controllability and the capability to decouple active and reactive power [26]. On the other side, a traditional diode rectifier is not a suitable choice for EV charging stations because it has a high input harmonic content, absorbing reactive power from the grid, which cannot be mitigated due to the lack of controllable switches. This phenomenon reduces the efficiency and deteriorates the voltage of the grid, which cannot be allowed considering the future spread of EV charging stations [38]. Furthermore, this topology is of boost-type, which means that its output voltage is higher than the peak value of the input AC line-to-line voltage [14], [39]. Three-phase PWM rectifier has already been analyzed for EV charging station applications in various papers [14], [38]–[45].

Another converter topology that can be used as an AC-DC stage in DC fast charging stations is the neutral-point-clamped (NPC) converter. It is made of three switching legs, each comprising four switching devices and two diodes used to clamp the output voltage to the voltage of the neutral point [26]. Considering the advantages of this topology compared to the three-phase PWM rectifier, the NPC converter offers a lower THD and provides less stress on the switching devices. Moreover, this topology can be exploited to create a bipolar DC architecture, which can be useful for DC fast charging stations with different battery voltages (e.g. 400 V to 800 V for EVs and 1000 V for electric trucks). However, the

disadvantage of a bipolar architecture is the complex control or extra circuitry needed to balance the voltage of the DC-link capacitors [14], [26], [46], [47]. Studies on NPC for DC fast charging stations have been already discussed in literature [48]–[50] as well as the comparison between NPC and two-level three-phase PWM rectifier [51]–[54].

The Vienna rectifier is a unidirectional topology made of a three-phase rectifier and three bidirectional switches. It was synthesized as a combination of the traditional three-phase rectifier and the boost converter to provide power factor correction (PFC) [55]. The main features of this topology are high power density, high efficiency, and very low THD. Moreover, it ensures less stress on the switching devices because of the neutral point as in the NPC converter [26], [56], [57]. Vienna rectifier has already been discussed in the literature on EV fast charging applications [14], [58]–[64]. Furthermore, the bidirectional version of the Vienna rectifier is essentially a t-type converter, which substitutes the diodes with MOSFETs. T-type converter maintains the features of the Vienna rectifier and allows the vehicle-to-grid (V2G) operation mode, making it a suitable candidate for DC fast chargers of EVs [26], [65]–[67].

The baseline AC-DC converter topologies are summarized in Table 5.

B. ISOLATED DC-DC CONVERTERS

The DC-DC conversion stages in DC-connected fast charging stations are typically isolated because IEC 61851-23 [68] states that DC fast charging stations with multiple outputs require isolation in each output, and a low frequency transformer per each output would be too expensive. Thus, the following subsection discusses isolated DC-DC converter topologies, which are usually used in real applications and adopted by the manufacturers.

TABLE 6: Comparison of conventional DC-DC converter topologies

Power Converter	Switches/ diodes	Capacitors/ Inductors	Isolation	Pros	Cons
Phase-shift full bridge	4/4	2/1	Yes	ZVS on the turn-on state of the switching devices.	Unidirectional topology. ZVS conditions not achievable for low load currents.
Dual active bridge	8/0	2/1	Yes	Bidirectional topology. Wide voltage gain and soft switching through proper modulation techniques	complex control techniques are needed to reach soft switching conditions in a closed loop system.
Three-phase dual active bridge	12/0	2/3	Yes	High power density. Low turn-off peak current. Low apparent power. Low high-frequency losses. Low rms currents in the input and output filter capacitors.	4 more switches compared to the dual active bridge. No modulation techniques targeting the soft-switching of the power devices are available
Unidirectional series resonant converter	4/4	3/1	Yes	Soft-switching conditions easy to achieve	Unidirectional topology and limited voltage gain
Bidirectional series resonant converter	8/8	3/1	Yes	Soft-switching conditions easy to achieve	Limited voltage gain
Buck converter	2/2	2/1	No	High power density, high efficiency, simple structure, reduction of the costs, and short circuit current limiting capability	No safety feature in case of V2G operating mode
Three-level buck converter	4/4	2/1	No	Less stress on the switching devices, smaller inductor size, reduced costs, possibility to operate in a bipolar configuration, and short circuit current limiting capability	More complex control strategies in case of a bipolar configuration, and no safety feature in case of V2G operating mode

One of the basic circuits to provide galvanic isolation in EV charging stations is the phase-shift full-bridge (PSFB). The PSFB is an unidirectional topology made of an active full-bridge on the primary side and a diode bridge on the secondary side. This topology is used for high-power and high-voltage applications such as DC fast charging stations [26], [69], [70]. An appealing feature of this converter is the zero voltage switching (ZVS) turn-on of the switching devices, which, however, cannot be exploited at light-load [26], [71].

In order to provide bidirectional power flow, the secondary side diode bridge in PSFB can be replaced by an active full-bridge, which creates a bidirectional dual active bridge (DAB) topology. The DAB converter is a well-known topology providing high power density and soft-switching capabilities, suitable for various applications such as microgrids, aerospace, and on/off-board battery chargers for EVs [26], [72]–[74]. A variation of the classical DAB topology is the three-phase DAB. This topology is adopted in high-power applications that require high power density. Compared to the traditional DAB topology, the three-phase DAB converter offers lower turn-off peak currents in the switching devices, lower apparent power, reduced high-frequency losses due to

the more sinusoidal waveforms of the currents going through the transformer windings, and lower rms currents in the input and output filtering capacitors, which in turn allows using electrolytic capacitors instead of the more expensive foil ones [75], [76]. However, its more complex structure does not allow the use of modulation techniques targeting extended soft-switching of the power devices. The phase shift modulation between the two bridges of the converter is, in fact, the only possible modulation, which in turn can reduce the efficiency of the converter itself [76].

Series resonant converters are a family of converters featuring a high-frequency transformer providing galvanic isolation and a series resonant tank made of an inductor and a capacitor. The first side can be a half-bridge, full-bridge, or even multilevel half/full-bridge, whereas the second side is usually a diode bridge in case of unidirectional topologies or an active half/full-bridge in case of bidirectional topologies [26]. The switching frequency of these converters is usually chosen slightly below the resonant frequency to implement zero current switching conditions (ZCS) [77]. In addition to their soft-switching capability, series resonant converters are also chosen for their fault-tolerant feature [26], [78]. Various

examples of series resonant converters for EV charging applications have been proposed in [79]–[81].

C. NON-ISOLATED DC-DC CONVERTERS

Single-stage non-isolated DC-DC converters are suitable for standalone AC-connected fast chargers that are isolated by means of a low-frequency transformer but, as explained in the previous subsection, are usually avoided in DC-connected fast charging stations because of their incompatibility with the current standards. Non-isolated topologies can also be used in the newest 800 V EVs to interface with the oldest fast charging stations designed for 400 V EV powertrain, as shown in [82]. Additionally, a non-isolated DC-DC converter can be paired with an isolated DC-DC converter to create a two-stage DC-DC isolated EV charger. An example of this concept is proposed in [83]. Typical advantages of non-isolated DC-DC converters are high efficiency, high power density, and reduced costs.

One of the simplest and most common bidirectional topologies is the half-bridge-based buck converter. It ensures high power density, high efficiency, low cost, and simple structure [84]. Another advantage that makes this topology appealing in fast charging solutions is its capability to limit the short circuit current when operating in buck mode for the grid-to-vehicle (G2V) operation [85]. However, such a converter does not guarantee the same short circuit current limiting capability in the case of V2G applications, in which it would behave as a boost converter. Moreover, it is possible to use buck converters as the basic topology of multi-phase interleaved converters. Due to a power distribution between phases, interleaved converters have increased power rating, increased efficiency at partial loads, and decreased output current and voltage ripple, which results in smaller filter components and better fault riding through capability [86]. The invention of a non-isolated DC fast charger based on an interleaved buck topology has been claimed in [87], but the status of this patent is still pending.

The three-level buck converter shows some advantages compared to the traditional buck converter. This topology leads to less stress on the switching devices, the capability to operate in a bipolar configuration, and smaller inductor size, which in turn results in reduced cost. However, the bipolar configuration also leads to a more complex control needed to balance the capacitors' voltages [88]–[90]. As with the traditional buck converter, this topology limits the short circuit current when operating in buck mode to charge the EV battery but not when operating in boost mode in V2G applications.

A summary of baseline DC-DC converter topologies is listed in Table 6. Moreover, two examples of real DC fast chargers are shown in Fig. 4 [13]. Fig. 4a shows the power architecture of ABB Terra HP, a standalone AC-connected charger rated at 150 kW. Here, since the galvanic isolation is provided by a low-frequency transformer, an interleaved buck converter is used as DC-DC conversion stage. Fig. 4b

shows instead the power architecture adopted in Enercon E-charger 600, which is a multi-port DC-connected fast charger. Here, PSFBs are used to provide galvanic isolation. The use of a single low-frequency transformer would not be sufficient in this case because IEC 61851-23 [68] clearly states that in a DC fast charging station equipped with multiple ports operating at the same time, every port requires isolation.

D. MV SOLUTIONS FOR DC FAST CHARGING STATIONS

In the classical configuration of an AC- or DC-connected fast charging system, the rectifiers are connected to an LV AC grid with 480 V phase-to-phase voltage in North America and 400 V phase-to-phase voltage in the rest of the world. In turn, such an LV AC grid is connected to an upper MV AC grid through a low-frequency isolation transformer. However, the latter is bulky and unable to provide any additional services. For these reasons, different examples of DC fast charging stations connected to the MV grid have been proposed, one of which is the solid-state transformer (SST). SST is typically made of several cells equipped with a rectifier and an isolated DC-DC converter that uses a medium or high-frequency transformer. It also requires additional DC-AC cells in the case of AC-AC applications, which, however, is not the typical study case for DC fast charging stations. Comprehensive reviews of SST-based MV solutions for DC fast charging stations have already been made in [14]–[16], [20]. SSTs are smaller and lighter than traditional low-frequency transformers. Moreover, they can provide ancillary services, such as power flow control, voltage sags compensation, fault current limitation, and DC bus regulation [91]. However, it has been proven that they cost more than traditional low-frequency transformers for the same operating range, especially in AC-AC applications, where they are not currently considered economically feasible [92], [93]. In fact, the price per kVA of low-frequency transformers decreases when the capacity increases, whereas the price of SSTs increases because of the limitations of SiC MOSFETs and efficiency standards [94]. The situation is different in AC-DC applications, where the SST can have similar losses and the cost gap is reduced [95]. This means that the SST could be an economically viable solution for the proper operation of future DC microgrids that integrate DC chargers, RESs, and traditional loads. Moreover, the adoption of SST-based charging solutions can be beneficial in big cities where there is a need for charging stations, but there is not enough space for the installation of bulky low-frequency transformers [14]. Another advantage of SST is its modular structure, which can be extended in case extra capacity is needed, whereas low-frequency transformers must be substituted [16]. Several SST-based MV solutions have already been proposed in the literature, and they can be made of one [96], [97] or several modules [98]–[101].

Modular multilevel converters (MMCs) have been proposed to interface the charging stations directly to the MV

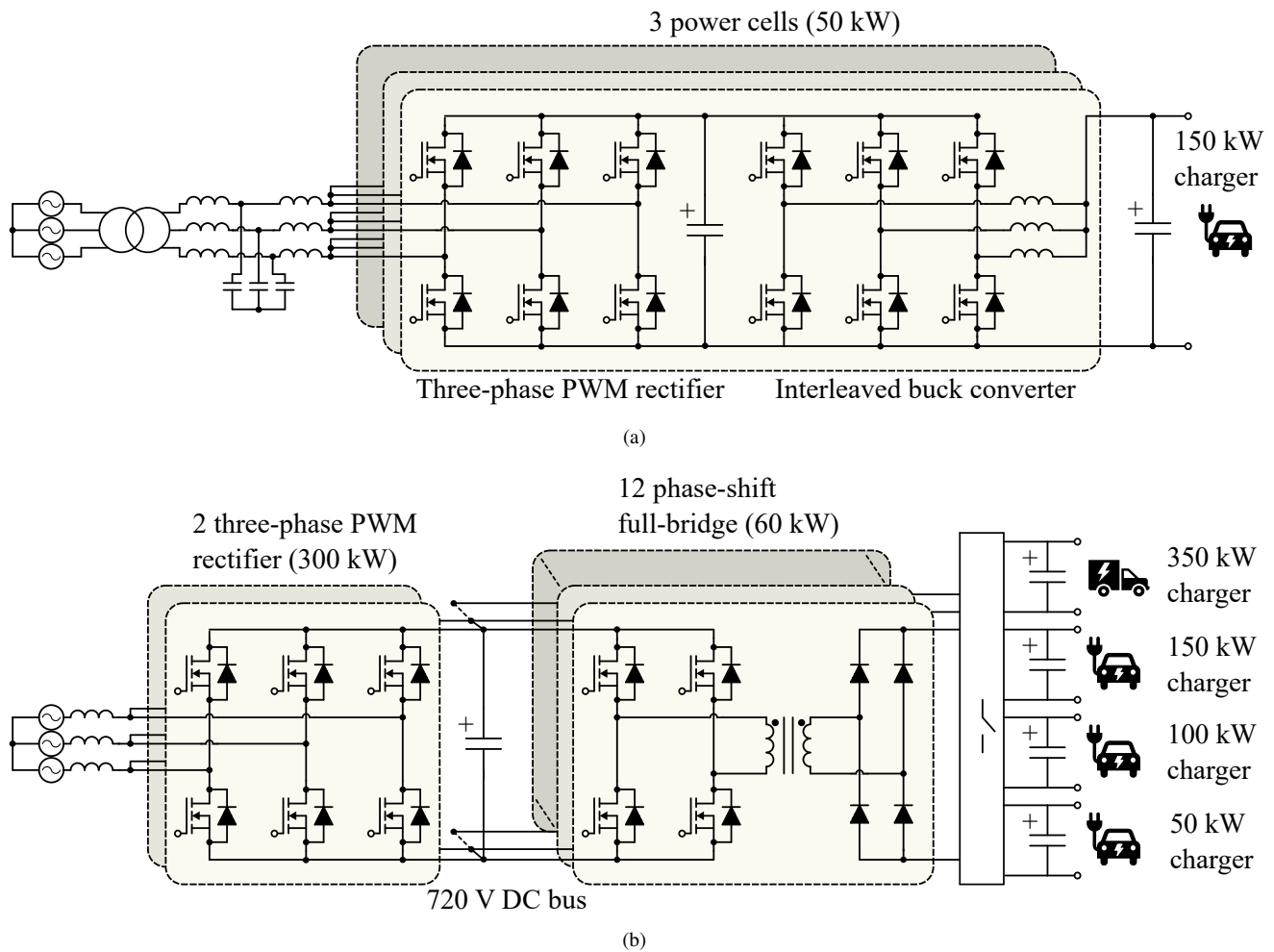

FIGURE 4: Examples of power conversion technologies adopted in real DC fast chargers. (a) ABB Terra HP. (b) Enercon E-charger 600 [13].

AC grid in standalone or SST configuration [102]. This approach allows to decrease the number of power conversion stages and, consequently, reduce the cost and increase the efficiency of the whole system. Other advantages that make MMC appealing as AC-DC stage for DC fast charging stations are its modularity, scalability, fault tolerance capability, low THD, and absence of DC-link capacitor [102]–[106]. MMC is made of three legs, each of them composed of two arms of converter submodules (SMs) connected in series. Arm inductors connect the two arms of each leg, and each submodule has an output capacitor. Different converters can be adopted as MMC submodules, such as half-bridge and full-bridge topologies [103]. However, among the disadvantages of MMC, the design and control complexity can be highlighted.

Cascaded H-bridge (CHB) is another suitable topology for MV solutions. The advantages of this configuration are the small size of passive components and the low current harmonics generated by the DC bus voltage ripple [107].

It can also provide an increased efficiency compared to the MMC for medium voltage applications [108] and better dynamic response [109]. Another similar cascaded topology is the cascaded-high-frequency converter, which has the advantage of being an isolated topology. An example of the application of such a converter in MV charging applications is given in [110].

E. PARTIAL POWER CONVERTERS

Partial power converters are among the emerging power converter topologies that have been proposed for DC (extreme) fast charging stations. The concept behind these topologies is to process only a fraction of the power delivered to the EV battery through the power converter, which keeps the voltage and current regulation, while the rest of the power is transferred through a direct connection to the source. This leads to increased efficiency because the power converter itself has little influence on the efficiency of the overall system. Moreover, this approach allows for a reduction in

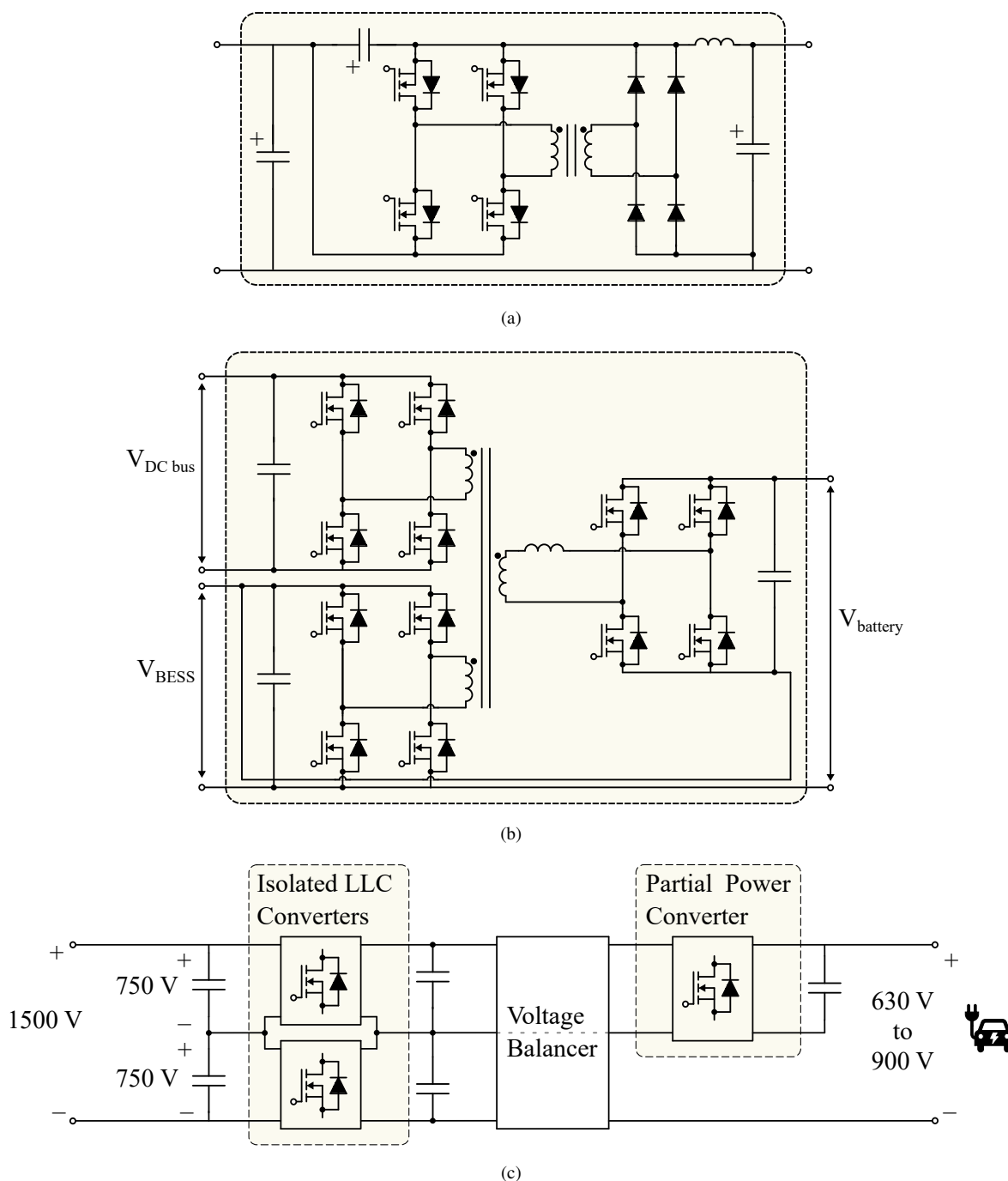

FIGURE 5: Partial power converters. (a) Partial power converter based on the PSFB topology [70]. (b) Multiport power converter based on a triple active bridge with a partial power processing port [111]. (c) Galvanically isolated EV charger architecture with voltage regulation based on partial power processing principles [112].

the power rating of the converter, which in turn means a reduction of the costs [113].

Two partial power converters based on a PSFB were proposed in [70] and [114]. Both of them have a low partiality ratio, i.e., the ratio between processed and delivered power, which in turn reduces the size, power loss, cost, and

stress on the switching devices. However, these works do not take into account the possibility of a V2G operation mode, and they do not consider EV powertrain architectures based on 800 V batteries. The partial power converters topology proposed in [70] is shown in Fig. 5a. It features series input port and parallel output port and performs voltage step-down

during EV battery charging, i.e., the DC link must be higher than the battery voltage.

Two buck-boost partial power converters based on high-frequency transformers were proposed in [115] to interface 400 V and 800 V EV powertrains. Both topologies have a full-bridge cell on the primary side, but the first one uses two-quadrant switches on the secondary side, whereas the other one uses an extra unfolding circuit. Buck-boost voltage functionality can be achieved only if a DC-DC cell inside a partial power converter can operate with different voltage polarities. This could be achieved in two ways:

- Using galvanically isolated current-fed DC-DC topology, where series port utilizes the DC inductor and 2- or 4-quadrant switches for unidirectional or bidirectional power flow, correspondingly.
- Using galvanically isolated voltage-fed DC-DC topology with an unfolded in the series port.

On one side, the second approach could appear as a more desired one due to the dominance of voltage-fed converters in the industry. On the other side, recent research shows that such solutions provide high performance only in a narrow voltage regulation range and suffer from excessive circulating energy, i.e., high RMS currents, while the current-fed solutions demonstrate balanced performance in a wide voltage regulation range and can perform zero voltage crossing (change of voltage polarity) at full current in series port [116], [117]. Similar results were obtained in [115], where the current-fed-based solution has shown better performances, and for this reason, it has been selected for fast-charging applications. Such a converter provides an estimated efficiency of over 99 %. In addition, a transformerless partial power converter was proposed in [118]. The converter topology is similar to the PSFB but with a capacitive network replacing the isolation transformer. This topology has been proven to be a reasonable solution for a wide range of EV batteries, from 400 V to 800 V. However, its scalability in power is limited due to the high current stress of the capacitors in the isolation capacitive network.

The main drawback of the presented partial power topologies is that they do not provide isolation between the DC bus and a charging port. It could be demonstrated that lack of transformer- or semiconductor-based isolation makes multi-port DC fast charging stations unreliable due to high susceptibility to a single fault event at any EV charging outlet [119]. On the other hand, we could expect PPCs to be used in the onboard chargers, where the battery voltage is known and could be matched with the DC link voltage of the front-end converter [120]. On the other hand, several hybrid approaches that provide galvanic isolation between the AC and DC grids and employ partial power processing principles for voltage regulation have appeared in the literature.

A multiport converter topology shown in Fig. 5b. is based on a triple active bridge (TAB) DC-DC converter. It was proposed in [111] to remove the need for an additional

converter in case a BESS is added to the DC fast charging station. The peculiarity of this partial power converter is that it provides isolation from the AC grid ($V_{DC\ bus}$ represents the DC link voltage of a front-end rectifier) but not from the BESS. This means that in case of fault, particular attention must be taken to detecting the faulty current on the BESS side. This topology was also compared to a triple active bridge and showed higher efficiency and reduced cost as the partial power processing port allows for delivering a high portion of the power directly from the BESS to the EV battery, using components rated for a fraction of the total power.

In recent years, two-stage energy conversion using a DC transformer (DCX) for high-efficiency galvanic isolation and voltage matching has demonstrated progress [121]. One example of such approach was presented in [112], where a charging converter was composed of 3 blocks, as shown in Fig. 5c:

- The isolation stage is composed of two series input series output connected LLC converters to provide galvanic isolation while sharing the input voltage stress. This stage operates as a DCX with the highest possible efficiency.
- Voltage balancer that ensures equal voltage sharing between the series capacitors. The efficiency of such a balancer was shown to be over 99.6 % in a wide power range [122].
- Partial power converter that is also connected to a midpoint of the series capacitors in the second DC link. As it operates only at half the voltage of the second DC link, all the regulation of the output voltage can be performed using power devices rated for half the voltage stress, i.e., using partial power processing.

This approach of combining an ultra-efficient voltage balancing converter with a transformerless partial power DC-DC converter has been demonstrated for PV applications, where it achieved remarkably high efficiency of up to 99.75 % [122].

F. EMERGING ISOLATED DC-DC CONVERTERS WITH WIDE CHARGING VOLTAGE RANGE

Other emerging converter topologies based on DAB, PSFB, and resonant converters and suitable for a wide output voltage range are described in this part to match the 400 V and 800 V EV batteries currently available on the market. It is worth mentioning that conventional topologies cannot operate in the required ultra-wide output voltage range, which urges the emergence of single-stage DC-DC converter topologies capable of operating in the required output voltage regulation range. As the overview below will demonstrate, this capability can often be achieved via reconfiguration of the DC-DC converter topology or connection structure.

A DAB-based converter was proposed in [125] to achieve a wide output voltage of 200 – 1000 V in DC fast charging

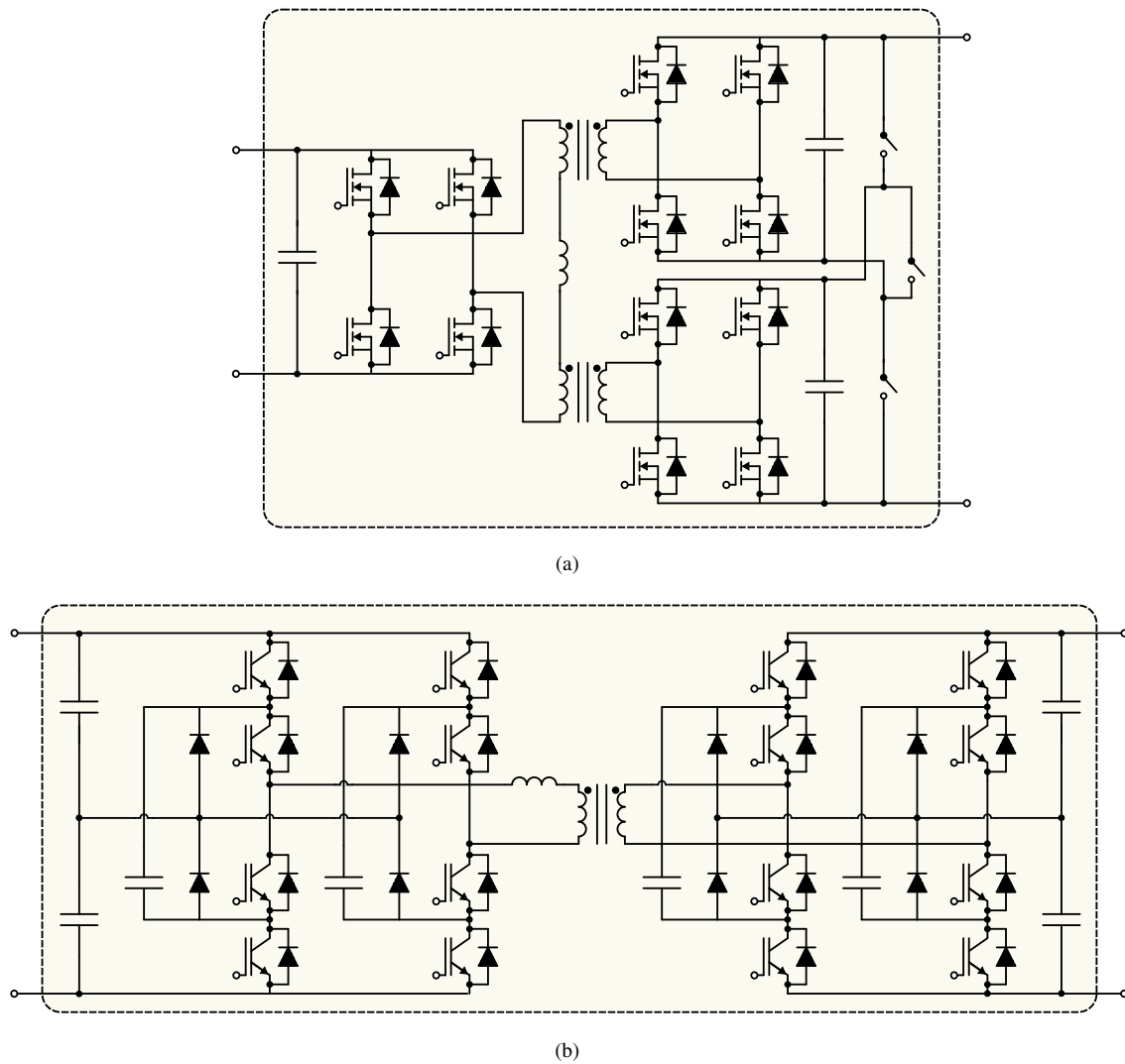

FIGURE 6: Emerging DC-DC converter topologies. (a) Bidirectional series-parallel TAB-based converter [123]. (b) Three-level DAB-based converter [124].

applications. Such a topology has two secondary bridges connected to the primary bridge through a three-winding transformer. Here, the output power is determined by the series inductors in the secondary windings of the transformers. The two secondary bridges can switch from a parallel to a series connection to achieve the high voltage gain. The proposed topology was able to keep an efficiency of more than 90 % over the entire voltage range considering different charging profiles, with a peak efficiency of 98.4 %. A design methodology based on the genetic algorithm was implemented to establish the optimal turn ratios and inductor values of the DAB-based topology. A disadvantage of such a topology is the circulating current in case of unbalances between the secondary sides of the transformer. Furthermore, DC offset and saturation of the transformer at extreme operational conditions, such as a high buck or boost mode,

may oblige the use of DC blocking capacitors, which in turn increases the cost of the topology and reduces its reliability. Also, the authors provided a comparison that reconfigurable topology can outperform multilevel DAB topology.

The same authors have published an alternative unidirectional implementation of the reconfigurable topology demonstrated in [125]. A reconfigurable topology based on the unidirectional LLC converter was proposed in [126] to match an input voltage of 800 V with a wide output voltage range of 200-1000 V for EV fast charging applications. This reconfigurable topology works in parallel mode for low output voltages and in series mode for high output voltage. The converter operates close to the resonant frequency to guarantee soft-switching conditions and limit the circulating currents on the primary side. As Table 7 demonstrates,

authors achieved slightly better efficiency across the wide voltage regulation range.

A similar topology adopting a three-winding transformer and an LLC resonant tank is presented in [127]. Here, the two output bridges are diode half bridges that can be arranged into 6 operation modes by exploiting two extra MOSFETs and diodes. In this way, the converter is able to achieve a very wide output voltage range of 100-1100 V within a relatively low operating frequency range of 50-155 kHz.

Another DAB-based converter with two LV bridges, two transformers, and additional series and parallel switches to reach high voltage gain was proposed in [123] in DC fast charging and BESS applications. Here, only one inductor between the primary sides of the two transformers is used to determine the power transfer. The paper shows that the proposed topology can significantly extend the voltage gain of a traditional DAB converter. However, a complex design is required to avoid common-mode current circulation and electromagnetic interference. This topology is shown in Fig. 6a.

An off-board charger was proposed in [124] using a three-level DAB as the DC-DC power conversion stage. A dual-phase shift (DPS) modulation and the particle swarm algorithm were used in this work to guarantee high voltage and power ranges while reducing current and voltage stresses. In particular, the particle swarm algorithm determines the inner and outer phase shifts of the DPS modulation using the peak inductor current as an optimization function. Such a topology is shown in Fig. 6b.

A new design methodology for a CLLC converter based on the parameter equivalent principle and the time domain model was proposed in [128] to extend the voltage gain range in on-board charging applications. The parameter equivalent principle is about calculating the equivalent parameters of a CLLC converter with different primary and secondary resonance frequencies, called a D-type CLLC converter, into a CLLC converter with the same resonance frequency on the primary and secondary side of the transformer, called S-type CLLC converter. Since CLLC converters can also be adopted as power modules of DC fast charging stations, this new design methodology has the potential to be applied in these applications.

Another design of the CLLC converter based on two NPC full-bridge cells was proposed in [129]. It is based on the possibility of reconfiguring the converter topology using topology morphing control (TMC) principles [130]. The TMC enables the CLLC converter operation in seven different modes, enhancing the battery charging voltage range to 200-700 V with a twofold-constrained switching frequency range. This approach embraces the full potential of the TMC with three-level topologies. On the other hand, it cannot provide the same performance as the three-port topologies with reconfigurable series/parallel connection of

two output ports, while it features a higher number of components.

A bidirectional reconfigurable three-level LLC converter was proposed in [131]. This converter can reach a wide voltage range just by varying the modulation of its two three-level full bridges. In particular, it generates two switching modes (full and half bridge) for the first and the second full bridge cells. Even though the switching modes for the two full bridges generate four different combinations, two of them share the same output voltage range. So, the proposed converter and modulation approach offer three different voltage gain ranges while keeping the switching frequency in a narrow range to keep the soft switching capabilities.

An MV solution based on an MMC converter was proposed in [132] to interface 400 V and 800 V EVs. Here, two second-life batteries and 400 V chargers are connected in parallel with the upper and lower arms, respectively, and they are also connected together in series. The MMC SMs are made of a half-bridge converter and a dual active bridge converter. The SMs are connected in parallel to interface up to six 400 V chargers and in series to interface up to three 800 V chargers. The main advantage of such a configuration is that it guarantees very high power thanks to the MV connection. However, the state of charge (SoC) of the two batteries connected to the upper and lower arms must be equalized with a proper control technique to avoid system instability. Moreover, the complex structure and high number of components do not provide a very high efficiency, which is 87 % for this topology.

A two-stage DC-DC converter based on a unidirectional LLC converter with a three-winding transformer, two diode rectifiers, and two two-phases interleaved buck converters was proposed in [83] for a 150-1000 V output voltage range. The proposed converter also uses three output switches to switch the connection between the two interleaved buck converters from parallel, adopted in an output voltage range of 150-500 V, to series, adopted in an output voltage range of 500-1000 V. The LLC stage is capable of reaching the ZVS condition on the primary side switches, whereas the interleaved buck converters do not keep the ZVS on the top switches for all the peak inductor current values. The converter is able to keep the efficiency higher than 95 % in all the output voltage range, with a peak efficiency of 97.7 %. However, the two-stage design makes this topology more complex, bulky, and potentially expensive compared to single-stage topologies.

A benchmark analysis was conducted in [133] to compare three unidirectional reconfigurable converters with wide output voltage range for EV charging applications based on the PSFB converter. The first converter, called r-PSFB, utilizes a three-winding transformer and two secondary diode bridges. The output of the two secondary diode bridges is connected to an extra circuit made of an inductor, a diode, a capacitor and a resistor. The output of such a converter is connected to three power switches to connect the converter in

TABLE 7: Comparison of emerging DC-DC converter topologies

Power Converter	Switches/ diodes	Capacitors/ Inductors	Isolation	Input/output voltage	Switching frequency	Peak efficiency	Pros	Cons
[70]	4/4	3/1	No	450 V / 320 – 390 V	100 kHz	99.11 %	Partiality of 13.32 %. Very low current ripple. Low stress on the transistors. Low thermal stress on the converter. Low cost	Hard switching observed at the peak efficiency. Unidirectional power flow.
[114]	4/5	3/1	No	300 V / 360 – 400 V	50 kHz	\simeq 98.5 %	Partial power ratio of 27 %. More efficient than a corresponding full-power converter. Low stress on the switches. Very low current ripple. Low cost.	Partiality ratio deteriorates at light-load conditions. Unidirectional power flow.
[115]	8/4	1/1	No	650 V / 350 – 1000 V	10 kHz	\simeq 99 %	Wide output voltage range compatible with both 400 V and 800 V batteries.	The efficiency decreases when the output voltage does not match the input voltage.
[118]	4/4	3/2	No	200 V & 400 V / 400 V & 800 V	20 kHz	98 %	Wide output voltage range. Very high power density.	Unidirectional power flow.
[111]	8/0	3/3	Partial (from grid)	400 V / 260 – 340 V (200 V for the BESS)	20 kHz	98.7 %	Higher efficiency, lower current stress of components, and lower cost than a traditional TAB.	The efficiency decreases when the grid port and the BESS port do not match the charging port. BESS fault current detection is required because of its lack of galvanic isolation. Partiality of 80 %.
[125]	12/0	3/2	Yes	800 V/200 – 1000 V	100 kHz	98.4 %	Minimized rms current stress under a wide voltage range. Reconfigurable series/parallel connection of output active bridges. Optimal converter design achieved by using the genetic algorithm	Circulating current might occur in case on unbalances between the two secondary windings of the transformer. DC offset and transformer saturation can also be an issue at severe operational conditions.
[123]	15/0	3/1	Yes	380 V/48 V	83 kHz	97.5 %	Wide output voltage range. DC-blocking capacitors are avoided. High efficiency is reached even at light load conditions.	Complex design is required to avoid common-mode current circulation and electromagnetic interference.
[128]	8/0	4/2	Yes	400 V/250 – 450 V	50 – 200 kHz	98.91 %	Reconfigurable series/parallel connection of output diode bridges. Extended ZVS compared to the CLLC symmetrical design to meet the wide output voltage requirement.	Poor controllability as in the CLLC symmetrical design.

[126]	4/8	5/1	Yes	800 V/200 – 1000 V	80 – 350 kHz	98.7 %	Output voltage range of 200 – 1000 V. Soft-switching capabilities and high efficiency as in the traditional LLC converter.	More complex control than in a traditional LLC converter due to the increased number of switches.
[127]	6/6	6/3	Yes	380 V/100-1100 V	50 155 kHz	-	Widest output voltage range among all the compared topologies. Soft-switching behaviour over almost all the operating range.	Unidirectional topology. Circulating currents in case of improper design of the magnetic components. Efficiency analysis not carried out yet.
[124]	16/8	8/1	Yes	300 V/108 – 260 V	20 kHz	≈ 95 %	Wide output voltage range. High power applications. Low stress on the switching devices. Low cost. Low EMI.	Complex design and control.
[131]	8/0	6/1	Yes	400/50 – 450 V	65 – 100 kHz	94.3 %	Wide output voltage range reachable within a narrow switching frequency range.	Improper switching mode transition may lead to disturbances.
[132]	120/0	24/18	Yes	15 kV ph-ph / 400 V or 800 V	-	87 %	High power possibilities due to the MV connection. Capability to interface 400 V and 800 V chargers.	Necessity to equalize the SoC of the BESSs to avoid system instability. Complex structure and a high number of components do not allow for achieving high efficiency.
[129]	16/8	10/2	Yes	750 V/200 – 700 V	31 – 70 kHz	96.8 %	Topology morphing control enables wide output voltage range of CLLC converter. V2G performance is proven in a wide range.	High number of components. Need to implement smooth transitions between modes. Uneven power loss distribution in different modes.
[83]	12/8	5/5	Yes	640-840 V/150-1000 V	15 kHz	97.66 %	Very wide output voltage range. ZVS on all the primary side switching devices of the LLC stage.	Unidirectional topology. ZVS does not occur on the top switches of the interleaved buck converters for all the peak inductor current values. The two-stage design makes this topology more complex, bulky, and expensive than single-stage topologies.
[133]	7/10	5/3	Yes	640 – 840 V/250 – 1000 V	45 kHz	97.76 %	Effective solution in terms of cost, power density and efficiency.	Unidirectional topology. The three-winding transformer, two secondary diode bridges, and additional output circuit make the design more complex than a conventional PSFB.

a series/parallel configuration. The second converter, called t-PSFB, uses a center tapped three-winding transformer and only one secondary bridge with the same output circuit as each diode bridge in the r-PSFB. Two extra switches are also placed in the center tap of the transformer and in the bottom connection to the output to achieve reconfigurability. The third converter is called i-PSFB and uses two transformers that have a common center tap. Moreover, the input side employs two active full-bridges, whereas the output side uses a three-leg diode rectifier. Yet, the same output circuitry adopted in the r-PSFB and t-PSFB topology is employed, but without any extra power switches. It can achieve parallel and series operation of the output transformer windings by changing modulation, thus, achieving a wide voltage regulation range. The three converters show more advantages than the conventional PSFB in terms of cost, power density, and efficiency. In particular, the experimental validation of an 11 kW r-PSFB converter with 640-840 V input voltage and 250-1000 V output voltage was carried out as this topology appeared the most promising from the first analysis. Its average and peak efficiency are respectively 97.3 % and 97.8 %, which qualifies such a topology as a promising solution for future DC fast charging stations.

It could be summarized that reconfigurable topologies demonstrate the widest charging voltage range. On one side, the TMC-based approaches appeared first and were applied to relatively complicated three-level CLLC and LLC resonant converters. Later research demonstrated that three-port resonant and phase-shift converters can cover a 200-1000 V battery charging voltage range when their two output ports can be reconfigured between series and parallel connections. The other isolated DC-DC topologies and implementation approaches cannot provide a similar battery charging voltage range. All the emerging topologies are discussed here and in subsection III.E are summarized in Table 7, also providing their input and output voltage, switching frequency, and peak efficiency.

IV. DC-CONNECTED FAST CHARGING STATIONS: ARCHITECTURES

As explained in section II, DC-connected fast charging stations have the potential to become the standard fast charging systems of the future, and for this reason, their main architectural features are discussed in this section. Here, the configuration, voltage polarity, and BESS integration of DC-connected fast charging systems will be addressed. Moreover, the case study of DC fast chargers integration into traction grids will be presented.

A. CONFIGURATIONS

The architecture configurations are used to indicate the type of connection of the DC microgrid with the AC-DC converter interfacing the upper AC grid, with the DC-DC converter interfacing the upper DC grid, and/or with the DC-DC converters interfacing RESs and BESSs. Such configurations

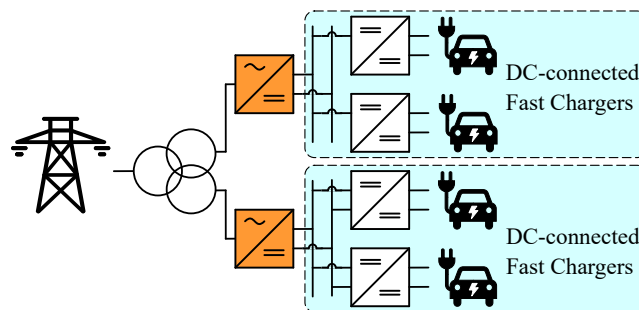

FIGURE 7: Split DC bus configuration for a DC-connected fast charging station as patented in [135].

are important because they determine the fault-tolerant capability of the DC fast charging station. However, the fault-tolerant features are associated with complex configurations [134].

1) Radial configuration

The radial configuration is the simplest architecture that is possible to realize in DC fast charging systems. In this configuration, all the electric vehicles and, eventually, RESs and BESSs are connected to the same DC bus. However, this also means that in case of a fault on the DC bus, all the charging stations will be disconnected, not guaranteeing continuity of service to the customers. A radial configuration has been depicted in Fig. 3b. A simple variation of this concept occurs when two rectifiers are connected to the grid and the charging station is split into two DC buses as shown in Fig. 7. Such a configuration can be useful to improve the stability of the DC buses, making the DC fast charging station more resilient. The invention of a radial configuration for DC-connected fast charging stations, including the case in which the charging station is split into two DC buses, has been patented in [135]. The Enercon E-charger 600 adopts a radial configuration [36], [37], as shown in Fig. 8, whereas the radial configuration with split DC bus is adopted in the Tritium NEVI System [35].

2) Ring configuration

The ring configuration is used to overcome the problem of continuity of service in case of faults. In fact, the DC bus is connected to the grid, BESSs, and RESs through at least two paths. In this way, if a fault occurs, it is possible to detect and isolate the particular faulty sector and guarantee continuity of service. The main problem of this configuration is associated with fault detection and location, which are necessary to isolate the faulty path. A ring configuration has been patented by ABB, including renewables and BESSs, as shown in Fig. 9. It also provides the opportunity to interface an AC or DC network in both LV and MV cases [136].

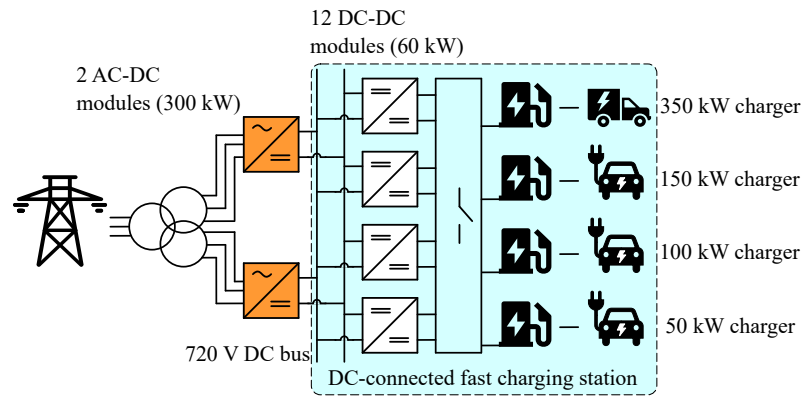

FIGURE 8: Power architecture of Enercon E-charger 600 [36], [37].

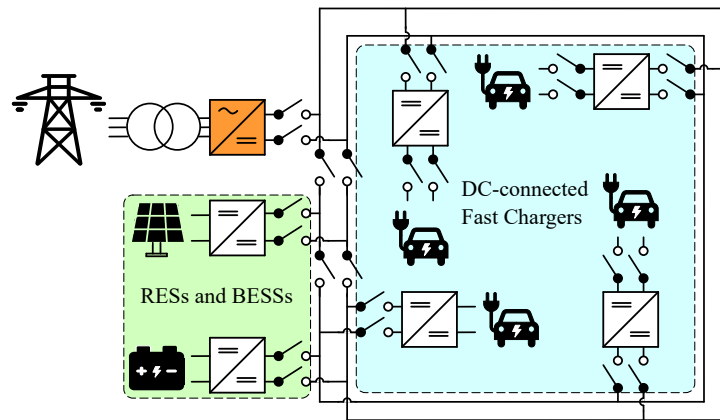

FIGURE 9: Ring configuration for a DC-connected fast charging station as proposed in [136].

The main features of radial and ring architecture are summarized in Table 8.

B. VOLTAGE POLARITY

The voltage polarity is another important point when talking about DC-connected fast charging systems. It must be chosen as a trade-off between ease of installation and resiliency of the architecture.

1) Unipolar architecture

In a unipolar architecture, all the chargers of the DC-connected fast charging system are connected to the same bus. The advantage of this kind of architecture is the ease of installation. However, it does not guarantee continuity of operation if the DC bus is under faulty conditions when all the chargers must be disconnected from the electric vehicles. Another point is the choice of the DC bus voltage, also considering the fact that future DC fast charging installations might be developed for EVs with different battery voltages, 400V and 800V, respectively; electric trucks, with a battery voltage of 1000V or even more in future; BESS and RESs with very variable voltages. The choice of DC bus voltage influences the number of DC-DC conversion stages that are

necessary to cover the required battery charging voltage range. Tritium PKM 150 and Tritium Nevi System use a DC bus voltage of 950 V [34], [35], whereas Enercon E-charger 600 adopts a 720 V DC bus [36], [37]. An interesting comparison between a common unipolar DC bus and a common AC bus for DC fast charging systems has been proposed in [137], where, the common unipolar DC bus was considered the best option because of its augmented efficiency and also because of the lower THD of current and voltage compared to the common AC bus case.

2) Bipolar architecture

A bipolar architecture uses the neutral point of the rectifier to split the bus into three voltage levels (e.g. $-V_{dc}$, 0, and V_{dc}). In this way, it is possible to connect the EV chargers to both polarities and to reconfigure the connection to the DC bus in case of line-to-ground fault. The main advantage of this configuration is that it allows to split the bus into two different voltage levels to charge different kinds of vehicles. For example, it is possible to charge electric vehicles with 400 V and 800 V batteries and electric trucks with a battery voltage of 1000 V, exploiting the different voltage levels of a bipolar architecture, as shown in Fig. 10. Here, as in

TABLE 8: Architecture features of DC-connected fast charging systems

Architecture	Configuration		Voltage polarity	
	Radial	Ring	Unipolar	Bipolar
Installation complexity	Low	High	Low	High
Installation costs	Low	High	Low	High
Operational costs	Low	High	Medium	Low
Resilience	Low	High	Low	High
Control complexity	N.A.*	N.A.	Low	High
Pros	Easy to design. The low complexity and costs are because only one bus is used to interface all the EVs, RESs, and BESSs.	Very resilient architecture. If one bus is faulty, the other buses guarantee continuity of service	Easy to design and control. It consists of only one bus connected to all the EVs, REs, and BESSs.	EVs, electric trucks, and RESs can be connected to two different voltage polarities based on their voltage values.
Cons	Service interruption in case of fault because only one bus is used to connect all the EVs, RESs and BESSs.	More complex installation and higher number of protection devices. Moreover, fault detection and location algorithms are needed to identify the faulty bus	More power conversion stages are needed to satisfy the battery voltages of different electric vehicles.	Design and installation are more difficult for such kinds of networks. Moreover, a complex control strategy for the voltages of the DC-link capacitors is needed.

* N.A.: not applicable.

unipolar architectures, the choice of the voltage levels is important to get the most efficient solution. It was concluded in a webinar organized by the European Union Commission that a ± 750 V DC bus can reduce the cable cross-section area by three times and the cable losses by 9 times in bipolar DC-connected fast charging systems compared to the fast charging stations connected to the three-phase 400 V AC grid [138]. However, no explicit consideration has been taken on the battery voltages associated with different EV powertrains. Yet, the main problem related to this kind of architecture is the voltage balance of the DC-link capacitors. Different solutions have already been proposed for bipolar DC-connected fast charging systems. An NPC converter with an additional voltage balancing circuitry is proposed in [49]. Even though this is a suitable solution, it implies additional cost. In order to overcome this problem, a voltage balance control through an NPC converter and high-power three-level converters was proposed in [48]. Moreover, an additional improvement was proposed in [139], where an active DC power balance control is applied in the bipolar architecture, whereas a passive DC power balance control was proposed to guarantee balanced operations, reduce the neutral point fluctuation currents, and so, decrease the size of the DC-link capacitors.

A summary of the main features of unipolar and bipolar architecture is given in Table 8.

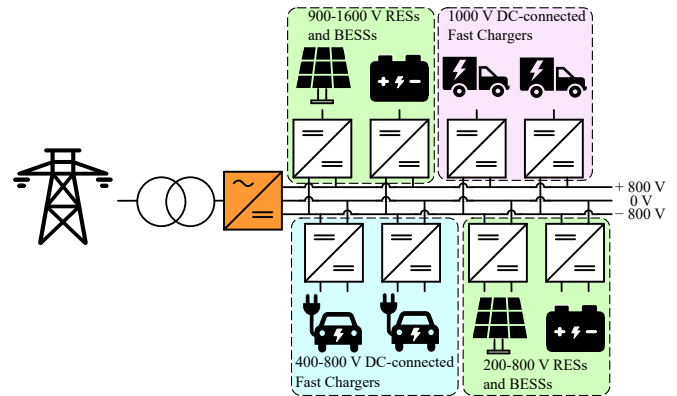

FIGURE 10: Example of DC-connected fast charging system in a bipolar architecture with a ± 800 V DC bus. The idea of a total 1600 V DC bus was inspired by [48].

C. MEGAWATT CHARGING STATIONS

One of the emerging concepts of the last few years is MW charging, usually referred as the future charging approach for MD and HD-EVs. MW charging is supposed to use the same power converter topologies already discussed in section III. However, MW charging is still not a mature technology due to its grid impact. As already discussed in Section II.A, CharIN proposed a standard capable of charging at up to 3.5 MW charging rate [28] and Nxu proposes its own

standard as well but they are both still far from wide scale adoption. Nxu also created the first commercial MW charger in 2023, rated at 4.5 MW charging power [140]. The interest on MW charging stations has also grown in academia, where the number of research papers is increasing. An example of academic project entirely dedicated to multi-port MW charging is explained in [141], which covers load analysis, grid impact, and power electronics design.

One of the main problems related to MD and HD-EVs and directly related to MW charging is the battery sizing of such vehicles. The battery size affects the distance range, the number of charging stops, and the charging duration. The battery capacity required by HD-EVs driving in German highways to reach the same distance of ICEVs is 825 kWh, which is almost 10 times the one of Audi e-tron GT. However, such a huge battery capacity affects the size and payload of HD-EVs, which is reduced to 80 % of the typical payload of HD-ICEVs, as stated in [142]. Moreover, the battery requirements for 42-tonne HD-EVs were addressed in [143] considering the mandatory 45-minutes rest every 4.5-hours required by European laws. This work found that the required battery capacity is 798 kWh in case of 1 stop every 4.5-hours. If the transportation companies are willing to increase the number of stops, it is possible to use smaller batteries and higher charging rates to save on the investment costs of HD-EVs and increase their payload.

Another problem affecting the spread of MW charging is the choice of a proper location where the grid infrastructure is powerful enough to provide the power required by an MW charging station. A feasibility assessment to find the location and proper power rating for a MW charging station was proposed in [144]. It turned out that if 80 % of the HD vehicles were electric, it would take 125 of MW-scale charging stations to recharge the HD-EVs with a range of 300 miles in the USA's West Coast daily. Such power is feasible considering that the peak power demand ever reached in California was about 52 GW on the 6th of September 2022. A method to find the location for a MW charging station based on geographical data and analytical analysis of its grid impact was presented in [145] using a realistic feeder from California.

One of the biggest concerns regarding MW charging is then their impact on the existing grid infrastructure. The grid impact of HD-EVs under different distribution systems and scenarios is analysed in [146]. It considers that the main characteristics of the grid impact generated by MW charging are station location, number of charging ports, charging load pattern, and feeder load patterns (residential or commercial). The main risk is that the voltage drops under the permissible limits causing blackouts and lack of service for sensitive users such as hospitals and emergency services. For this reason, the paper proposes the optimal sizing of PV unit and BESS to reduce the grid impact and the costs. To further mitigate the grid impact of HD-EVs, three voltage control strategies were compared in [147]. The three control

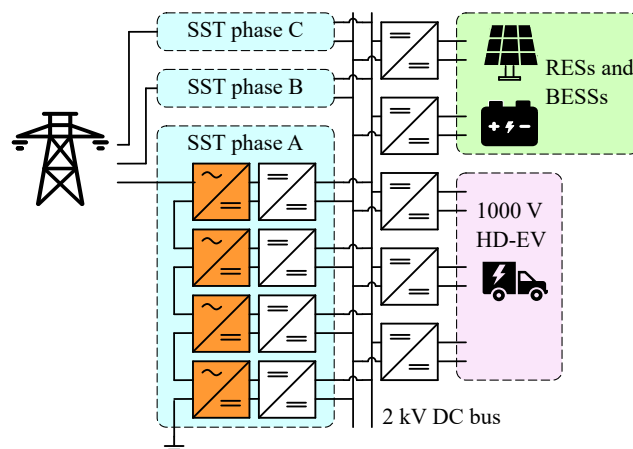

FIGURE 11: MW charger proposed in [149], [151].

strategies are the power factor control, standardized volt-volt ampere reactive control, and a customized volt-VAR curve control. They are compared under different distribution systems and different numbers of charging ports – one, three, or six 1.2 MW rated ports. All the methods show similar performances when the MW charging station has 1 or 3 charging ports, whereas the customized volt-VAR curve control shows the best performances in the scenario with 6 charging ports.

A popular architecture of MW charging stations adopted in literature was firstly proposed in [148]. Here, an SST configuration is adopted, where each phase of a 4.16/4.8 kV grid is connected to an N-cell CHB converter, which is in turn connected to N DAB converters and to the DC bus. The DC bus is then connected to the HD-EV chargers, BESS, and RESs. A similar architecture was then proposed in [149] to charge a 1.2 MW HD-EV with 3 DAB converters rated at 400 kW and separately connected to the HD-EV, because of the cable weight limitations given by the USA's Occupational Safety and Health Administration (OSHA) [150]. The paper proposes a three-level hierarchical control and demonstrates the control hardware in the loop (CHIL) implementation of two of the three levels, whereas the third level related to the energy management was developed in [151]. The MW charging system proposed in [149], [151] is shown in Fig. 11. Even though the research publications are moving towards MW charging architectures with SST, there is no comparative study that clearly states the practical advantages and disadvantages of such an architecture compared to the use of a low-frequency transformer. So, the use of the SST for MW charging systems is still an open point and future research activities must clarify if this design choice is really economically viable.

D. BATTERY ENERGY STORAGE INTEGRATION

This subsection aims to show the benefits provided by the adoption of BESSs in DC fast charging stations, which are, respectively, savings of grid reinforcement costs and opera-

tional cost as well as better on-site utilization of RESs [18], [26]. Moreover, some examples of architecture employing BESSs will be described.

1) Grid reinforcement costs

BESSs are advantageous solutions where the grid infrastructure is weaker, like in highway and countryside settings, where DC fast charging stations are needed for long-distance trips. In such cases, in fact, the improvement of the grid infrastructure would be much more expensive than the installation of BESSs [18], [26]. The installation of BESS for avoiding grid reinforcement costs has been evaluated in [152]. It has been calculated that BESS is an advantageous solution in case of load profiles with short power peaks, such as a motorway rest area, whereas grid reinforcement is more convenient in case of load profiles with long power peaks, such as an electric bus depot.

2) Operational costs

Moreover, BESSs are proven to reduce the operational costs. BESSs can be charged when the electricity price is lower and discharged towards the EV batteries when the electricity price is higher. Yet, BESSs can be charged with a lower power rate than a DC fast charging station, which further decreases the operational costs [18], [26]. An evaluation of the operational costs determined by stationary batteries and intraday trading for DC fast charging stations located in cities and highways was addressed in [153]. Here, it was found that stationary BESSs usually lead to higher profits for DC fast charging stations located in cities compared to intraday trading. Moreover, stationary batteries are also recommended for DC fast charging stations located on highways rather than intraday trading because the higher power rating could fasten the deterioration of the BESS.

3) Interfacing of the renewable energy sources

Finally, BESSs are a valid choice to increase the utilization of RESs. BESSs can be charged by RESs during the peak energy production time, such as the sunny days for photovoltaic (PV) panels, and discharged towards the EV batteries during the low energy production time, such as the night with no PV power generated [18], [26]. A review of BESSs sizing criteria to interface RESs has been given in [154].

4) Examples of battery energy storage integration

As the main advantages of BESSs in DC fast charging stations have been discussed, several examples of architectures employing BESSs are provided below.

A first example of BESS integration has already been described above when referring to [132], where second-life batteries are used as BESSs interfacing the output of an MMC with 400 V and 800 V fast chargers. Such batteries

are connected in series and in parallel with the upper and lower MMC arms. In this way, the SMs of the MMC can be connected in parallel to interface up to six 400 V chargers and in series to interface up to three 800 V chargers. The problem with this architecture is that the SoC of batteries must be kept at the same level to avoid system instabilities.

A study regarding the introduction of a BESS to support the DC-connected fast charging system when the charging demand exceeds the capability of the grid has been conducted in [155]. Here, a grid-tie rectifier and the BESS are used to reduce the impact of the peak hours demand on the grid and to eliminate the DC bus voltage ripple and harmonics in the AC grid.

The integration of BESSs in DC fast charging systems was claimed in the patent [156]. Here, different embodiments demonstrate how the BESSs can be connected to the DC fast charging stations.

The invention of split battery storage for fast charging of EVs was instead claimed in the patent [157], where an LV and HV batteries are combined in series along with power electronics to enhance grid support capabilities of the charger. The main advantage of such a structure is that it can support and balance the grid in a more meaningful way than existing chargers with BESS integration. Moreover, the patent claims that such an architecture can reduce the number of power converters because it does not require two-stage converters, minimizing heat generation and related cooling costs. Moreover, this architecture allows vehicle-to-grid operation even when the EV is not connected, thanks to the presence of the batteries. Furthermore, a paper about split energy storage [66] shows that this kind of architecture reduces the semiconductor losses and, in turn, allows for an increase in the power density of the power converters adopted in the high-power charger.

A novel DC-connected fast charging system based on a multi-BESS was proposed in [158]. The system includes three BESSs, a connection to the grid through a grid-tie inverter, a PV unit, and two EV fast chargers rated at 175 kW. The novelty of this system consists in the absence of DC-DC converters to interface the system components. Moreover, switching matrices are connected to the BESSs so that every BESS is connected to only one of the other four components simultaneously.

E. DC FAST CHARGERS INTEGRATION INTO TRACTION GRIDS

As a result of the increasing number of fast charging stations, the issue of their integration into existing electrical power networks becomes relevant. One of the potential networks for connection is the public traction network, which is associated with its following advantages: substantial coverage in urban and suburban areas; sufficiently high substation capacities capable of supplying high-power for electric vehicle charging stations [159]; traction substations are loaded only during periods of intensive transport movement, which allows their

usage for EV charging at other time when transport movement intensity is moderate or absent [160].

The typical voltage levels of DC traction networks are 750 V DC (600 V DC), 1500 V DC, 3000 V DC, and 15 kV AC at 16.7 Hz, and 25 kV AC at 50/60 Hz. Substation power can vary depending on rolling stock traction network structure and usually ranges from 1 MW to 10 MW [161]. Thus, the great power capability of traction substations allows to connect to them fast charging stations with power up to 400 kW. However, it is essential to note the limitations associated with charging stations integration into traction networks.

The first problem is the voltage instability of the traction networks, which is associated with the acceleration and regenerative braking of traction vehicles. For lines with a nominal voltage of 1500V, the voltage fluctuates between 1000V and 1800V during train acceleration and braking [162], which significantly complicates the design of charging station converters.

The second issue arises during periods of high traction transport movement intensity, which results in a high peak consumption from substation equipment that potentially reaches the maximum power rating of the substation. Charging EVs during such moments is undesirable, as it may lead to equipment overload and failure. Therefore, smart charging algorithms are actively employed to reduce the vehicle charging power when the substation is heavily loaded [163]. For example, intelligent multi-vehicle charging algorithm that take into account various LV DC tram grid and EV charger parameters were investigated in [164]. Also, the simulation-based study given in [165] shows the potential of the integration of PV panels, fast charging stations, and railway network to obtain mutual advantages, such as increased transport and RES utilization, and economic benefits.

However, it should be noted that EV smart charging methods increase the total EV charging time, which is undesirable for EV fast charging. To address this issue, buffer energy storage systems connected to the traction line are used, as shown in Fig. 12 [166]. The buffer batteries are charged from the substation at a lower power rating using smart charging algorithms, preventing overloads of the substation. Then, such buffer batteries are used as a source of energy to fast charge EVs with a much higher power rating. Additionally, connection to the line buffer batteries allow to provide ancillary services to a DC traction grid, such as line voltage stabilization and braking energy recuperation.

In the case of the AC traction grids, due to high voltage levels, a typical scheme with MV to LV low-frequency transformers and consequent AC-DC rectifiers is used [20]. However, due to wide voltage fluctuations on MV AC traction lines, such connection is recommended only in proximity to the substation, where voltage is relatively stable. To overcome this limitation and omit the usage of an AC-DC rectifier, connection to the DC-links of additional substation equipment is discussed in the literature. For example, in

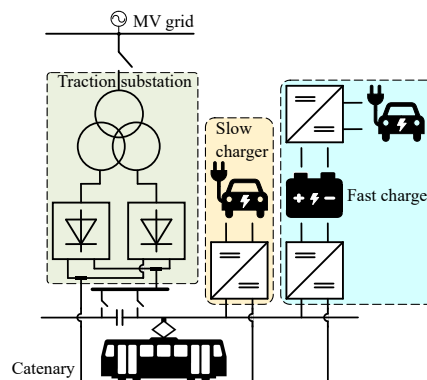

FIGURE 12: EV charger direct connection to the DC traction line.

[167], the connection to different types of rail power conditioners (RPC) in a railway system is discussed. Connection to the stable DC-link of such equipment simplifies DC fast charger connection and reduces requirements for a converter, which positively impacts the converter price. Another option could be the connection of EV chargers into the DC-link of a hybrid feeder substation, discussed in [168]. However, the main drawback of EV chargers integration into RPC and hybrid substations is their low prevalence, which results in a limited application.

F. Safety, protection, and isolation requirements

The adoption of high power rated by DC fast charging stations raises concerns about personal safety and the security of the power grid. For this reason, this section aims to first provide an explanation about the safety issues and a way to quantify them, and then to explain the protection and isolation requirements of the standards currently adopted in DC fast charging stations.

1) Safety

DC fast charging introduces safety concerns due to the high power delivered to the EVs. Thermal runaway of the lithium-ion battery is the biggest safety issue, leading to fire and explosions, and it is more likely to happen during charging at a high power rate. Overcharge and short circuits of battery cells are among the causes of thermal runaway [169]. For this reason, it is important to consider proper safety measures when dealing with DC fast charging stations. Recommendations against fire can be found in [170]. Among the suggestions given in that document, the location of the charging station and the distance between each charging piles are given. Moreover, the use of sprinklers is recommended as a first aid measure before the intervention of the fire emergency service.

Risk assessment metric on injuries and health damages is given in [171] as follows:

$$Rt = \sum_i Po_i \times Se_i \quad (1)$$

where Rt represents the risk of dangerous voltages for EV owners and the risk of arch flash for workers during maintenance. Moreover, Po_i is the probability of injury or health damage, and Se_i represents the severity of such an occurrence.

Another risk metric given in the same work is the energy not supplied factor ENSF, which represents the risk of damage to the power grid. The ENSF is given by:

$$ENSF = \alpha(EENS - EENS') \quad (2)$$

where EENS and EENS' are the total amount of energy not supplied in the grid when considering respectively the presence and the absence of an EV charging station:

$$EENS = \sum_i EENS_i \quad (3)$$

whereas α is the contribution factor of an EV charging station, determined as the ratio between the rated capacity of the charging station and its maximum capacity:

$$\alpha = \frac{C_{rated}}{C_{total}} \quad (4)$$

2) Safety Thresholds and Protection Devices

IEC 61851-1 [172] and IEC 61851-23 [68] states the touch current limits that should be not exceeded between the AC supply and the touchable parts of the DC fast charging station, which is 3.5 mA for Protection class I chargers and 0.25 mA for Protection class II chargers. Protection class I and class II devices are defined in IEC 61140 [173]. In particular, Protection class I defines the devices that have at least basic insulation and connection with the protective conductor, whereas Protection class II defines the devices with basic insulation and additional insulation for fault protection or reinforced insulation [174]. It is worth underlining that the touch current limits that have been described in this part are between the AC supply and the touchable parts of a DC charger, whereas there is no standard that mentions touch current limits between the DC bus and the touchable parts of the charger in case of shared DC bus.

IEC 61851-1 also affirms that the power supply equipment for DC fast charging stations must be equipped with a protective grounding conductor connected either from the input grounding connection point of the upper AC grid to the EV, or from the power supply device to the EV if electrical isolation is given. If the charging station has multiple connection points supplying energy to the EVs and they work simultaneously, all of them need integrated protection. If they do not work simultaneously, a common protection system is sufficient. Moreover, if the EV power supply is not equipped with electrical isolation, its residual current device (RCD) must be rated for a current of 30 mA.

Regarding the other protective measures proposed by the IEC 61851-23 standard, the continuity of the protective conductor must be continuously monitored through an appropriate monitoring device. If it detects a voltage higher than 60 V, it must shut down the system within 10 ms. Moreover, the DC fast charging station must check the insulation resistance between the output and the protective conductor to the chassis before charging, and prevent charging in case the threshold value is not reached. Furthermore, overvoltage protection must be guaranteed by disconnecting the system in case of fault within time limits that depend on the charging station type and are specified in the IEC 61851-23 standard as well.

IEC 6181-23 also defines the maximum allowed voltage in DC fast charging stations with different output voltage ratings. DC fast charging stations with an output voltage of up to 500 V must not provide an output voltage greater than 550 V for more than 5 s. In the same way, DC fast charging stations with an output voltage between 550 V and 1000 V must not provide an output voltage greater than 110 % of their rated output voltage for more than 5 s. DC fast charging stations with voltages above 1000 V are still under discussion. Moreover, the overvoltage between the + and - polarities must never exceed 2500 V. The DC fast charging station must also be provided with a short circuit protection device able to shut down the system within 1 s after the short circuit occurs.

3) Isolation

Galvanic isolation is implemented to avoid the impact of faults and instabilities in DC fast charging stations on the distribution grid. The galvanic isolation can be provided by means of a low-frequency transformer between the AC power supply and the inverter of the DC fast charger, a medium or high-frequency transformer as part of the DC-DC conversion stage, or as a combination of both solutions. The advantage of using high-frequency transformers is that they are smaller, lighter, and more efficient than low-frequency transformers [11], [14], [26]. Moreover, it is possible to decrease the size of the converter by increasing the switching frequency when using a high-frequency transformer under the MHz range [175]. A solid-state transformer (SST) can also be considered a solution providing the galvanic isolation. The SST usually comprises two power conversion stages in AC-DC applications, an AC-DC converter, and an isolated DC-DC converter [15]. A comparison between high-frequency and low-frequency transformers for a DC fast charging application is further provided in [41].

IEC 61851-23 specifically discusses the requirements for the galvanically isolated DC fast charging stations, whereas it does not address non-isolated DC fast chargers. The standard affirms that the insulation between the secondary side of the transformer and the ground must be monitored through an insulation monitoring device. Moreover, the standard

discusses galvanically isolated DC fast charging stations with multiple outputs, in both shared and non-shared DC bus configurations. All the outputs of such a kind of system must be connected to the same protective conductor and each of them must be equipped with an insulation monitoring device. In the same way, every output must be equipped with a short circuit protection device and an overvoltage protection device. If the multiple outputs are meant to operate at the same time, then they must be electrically isolated by means of a low-frequency or high-frequency transformer. Furthermore, if a fault occurs in even only one of the output ports, all the DC fast charger ports must stop the charging process.

On the other side, non-isolated chargers could be a more efficient solution leading to a reduction of the costs due to the isolation requirements. However, the main problem with non-isolated chargers is the common-mode leakage current, which determines electromagnetic interference (EMI) in the EV powertrain and electric shock to EV users. The best way to mitigate the common mode leakage current is to improve the design of the output filters of the DC fast charging stations, whereas solutions based on particular modulation techniques of the power converters do not lead to a significant reduction of the common mode leakage current [176].

V. ENERGY MANAGEMENT FOR DC FAST CHARGING STATIONS

This section reviews the energy management strategies for DC fast charging stations. First, the energy management goals for DC fast charging stations are introduced. Then, the energy management strategies are presented. Finally, the state of the art of each energy management strategy is discussed.

A. GOALS OF ENERGY MANAGEMENT FOR DC FAST CHARGING STATIONS

The main goals of charging stations for electric vehicles in general have been defined in [23], and they are, respectively:

- 1) Minimize the operational costs. This can be achieved, for example, by using RESs and BESSs during the peak demand hours.
- 2) Maximize the quality of service (QoS). The definition of QoS can vary depending on the EV customer needs. However, it is usually defined as the capability of the charger to charge the EV to the SOC desired by the customer in the time desired by the customer.
- 3) Charging schedule. This is important when several customers are waiting to charge their vehicles.
- 4) Ancillary services, like voltage regulation, frequency regulation, and energy reserves. The latter is provisioned using energy stored in EVs as they can be considered BESSs when needed.
- 5) The demand response put together the concepts of load shifting and peak shaving.

- a) Load shifting means that the EVs are charged at full power during low demand periods, whereas they are charged at lower power or even not charged during high demand periods.
- b) Peak shaving means instead that during the time of peak demand an EV can provide energy for the grid or for other EVs in the same charging station.

B. ENERGY MANAGEMENT STRATEGIES

Some of the energy management strategies adopted in all study areas can also be used for DC fast charging stations. They can be divided as follows [22], [194]–[196]:

- 1) Optimization-based approaches, which are related to the low-level control of the DC fast charging station through optimization algorithms. These algorithms are further divided as follows:
 - a) Global optimization, which refers to the use of modern data-based optimization algorithms that do not need knowledge about the dynamic behavior of the system. Examples of these algorithms are the genetic and particle swarm algorithms.
 - b) Real-time optimization, which instead refers to control strategies that require knowledge about the dynamic behavior of the system. Model predictive control and robust control strategies are examples of real-time optimization control.
- 2) Rule-based approaches, which are related to rule-based algorithms, can be divided in turn into:
 - a) Deterministic rule-based methods such as state machine-based strategies.
 - b) Non-deterministic rule-based methods such as fuzzy logic algorithms.

All the optimization strategies described in this section have been classified in Table 9 based on the energy management goals and in Fig. 13 based on the energy management strategies. Examples of such optimization strategies are explained as follows.

1) Global optimization

A charging schedule based on a stochastic algorithm called flexibility envelope [197], [198] was developed in [177] to increase the daily profit of the fast charging station, to decrease the impact on the utility grid by minimizing the power exchanged with it, and to reduce the waiting time of the EVs for charging.

A centralized EMS based on Newton's method and the barrier method was developed in [178] to control the charging schedule of a DC-connected fast charging system without BESS and RESs. The paper defines an optimization function to minimize the overall consumption of all the EVs connected to the fast charging station. The constraints are

TABLE 9: Energy management works on DC fast charging stations

Research work	Operational costs	QoS	Charging schedule	Power imported from the grid	Ancillary services			Demand response		V2X
					Voltage regulaton	Frequency regula-tion	Energy reserve	Load shifting	Peak shaving	
[158]	×	✓	×	✓	×	×	✓	×	×	×
[177]	✓	✓	✓	✓	×	×	×	×	×	×
[178]	✓	×	✓	✓	✓	×	×	×	×	×
[179]	✓	×	×	✓	×	×	×	×	×	×
[180]	✓	×	✓	✓	×	×	✓	×	×	×
[181]	✓	×	×	×	×	×	×	×	×	×
[182]	✓	×	✓	✓	×	×	×	×	×	✓
[183]	✓	×	✓	✓	×	×	✓	×	×	✓
[151]	×	×	×	✓	×	×	✓	×	×	×
[184]	✓	×	×	✓	×	×	✓	×	×	×
[185]	✓	✓	×	✓	✓	×	×	×	×	×
[186]	✓	✓	✓	✓	×	×	×	×	✓	✓
[187]	✓	×	×	✓	×	×	✓	×	×	×
[188]	×	×	×	✓	✓	✓	✓	×	×	×
[189]	✓	×	×	✓	×	×	✓	✓	×	×
[190]	×	×	×	✓	×	×	✓	✓	✓	✓
[191]	×	×	×	✓	×	×	×	×	×	×
[192]	×	✓	×	×	×	×	×	×	×	×
[193]	×	×	×	✓	×	×	✓	×	✓	✓

×: not covered in the research work.

✓: covered in the research work.

on the minimum and maximum charging power of the fast charging station, the intermediate and final value of the SOC of the EV batteries, the lower and upper limits of the SOC, the desired state of charge, and the voltage limits. The algorithm was able to reduce the peak power demand during the charging process of the EVs. However, the centralized algorithm shows worse performances when increasing the number of charging spots, which means that it is necessary to adapt and improve the charging protocols and devices when scaling up the charging station.

A multi-objective optimization was proposed in [179] for the optimal sizing of a PV unit and a BESS in a DC-connected fast charging system. The two optimization functions developed in this paper target the operational costs and the pollution generated from non-renewable energy production. A weighted sum method was used to merge the two optimization functions into one, and then the genetic algorithm (GA) was used to solve such an optimization function. The proposed model was simulated with the study case of DC fast charging stations located along Italian highways.

An EMS and a new charging topology were proposed in [180] to suppress the peak power demand of DC fast charging stations for pure electric buses. Here, the parti-

cle swarm optimization algorithm is used to manage the charging schedule of the electric buses, whereas linear programming is used to design the BESS. This double strategy was simulated through the real data of a DC fast charging station for electric buses in Beijing. The results proved that this approach can reduce the peak demand, the electricity cost, the load fluctuation during charging, and the size of the BESS.

A supervised machine learning algorithm for the optimal sizing of a PV unit, a wind turbine, and a BESS was proposed in [181] to reduce the electricity cost of a grid-connected home with a fast charger. The machine learning algorithm adopted in the paper is called the group method of data handling, which is a feed-forward neural network with supervised learning. The optimization function is the minimum cost of electricity with constraints on the actual power provided by RESs, the rated charging and discharging power of the BESS, its SoC, the EV charging power, the EV battery SoC, and the power imported/exported from/to the grid.

A MILP approach based on three different optimization functions has been proposed in [182] for a DC-connected fast charging station interfaced with the upper AC grid and equipped with a BESS and a PV unit. The peculiarity of such

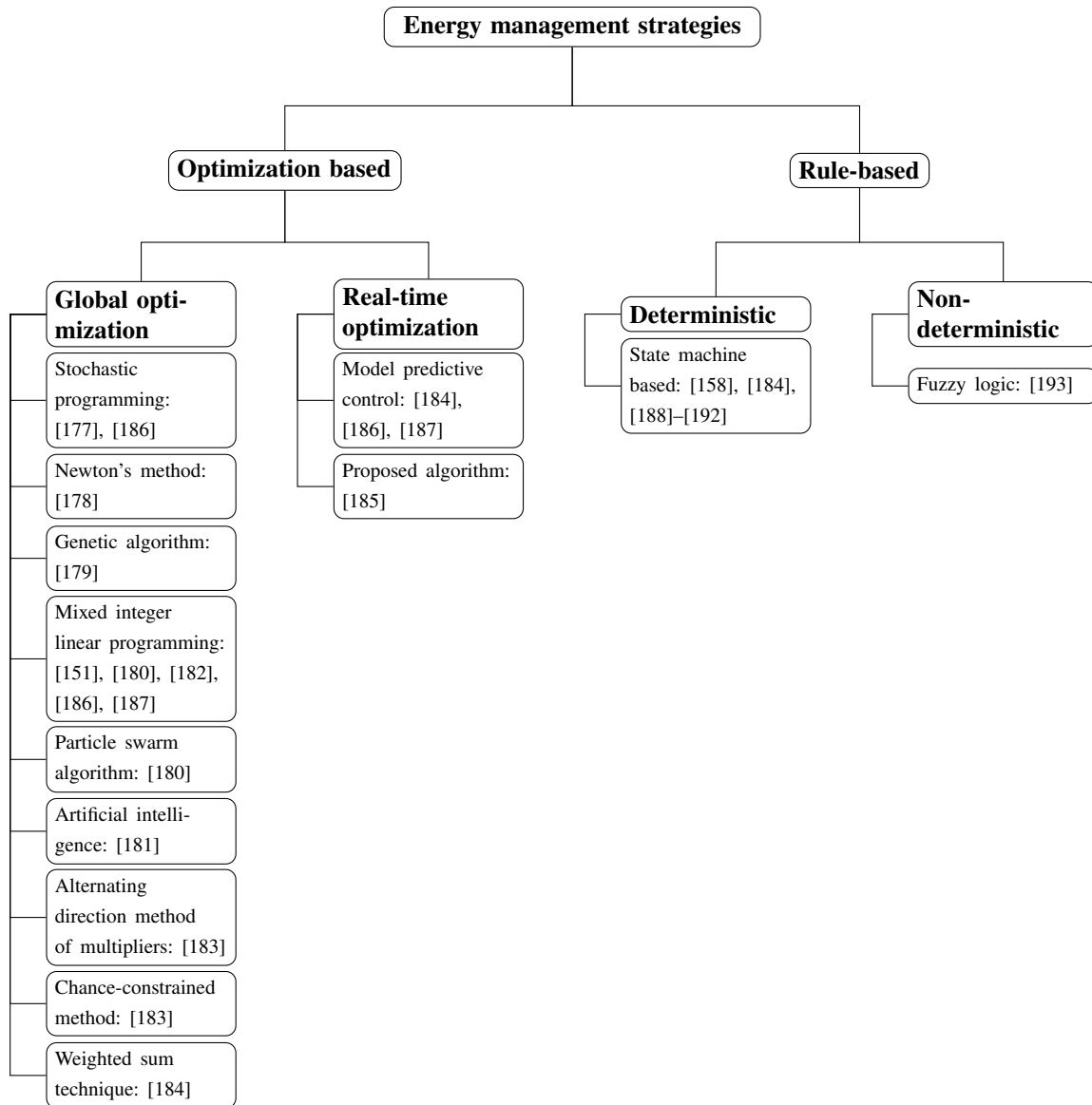

FIGURE 13: Energy management algorithms classified by the related energy management strategy.

a DC-connected fast charging station is that it is designed for the slow charging of EVs at a 10 kW power rate. The three optimization functions aim to respectively minimize the operational costs, the power exchanged with the grid [199], and again the operational costs but with constraints on the power exchanged with the grids and the EVs. The number and length of the routes traveled by the EVs are described by Gaussian, Poisson, and Weibull distributions, and they are evaluated through proper indicators, such as operational costs, battery performances, power exchanged with the grid, and discharged cycles of EV batteries and BESS. The optimization functions have been evaluated under a summer and a winter day weather condition, and under a high number and a low number of EV arrivals, resulting in four different scenarios. The results show that the V2G operation mode is

more frequent when the EV battery wearing costs are not taken into account and that the higher PV generation leads to lower operational costs.

As a continuation of [182] and [200], a two-level algorithm based on alternating direction method of multipliers (ADMM) and chance-constrained optimization was developed in [183] for a local energy community interfaced with a DC-connected DC fast charging station equipped with a BESS and a PV unit. The first level of such an optimization algorithm regulates the power exchanged inside the energy community by the prosumers, utility grid, BESS, and EVs, taking into account the cost of energy bought from or sold to the utility grid. Here, the ADMM optimization technique is adopted. The second level optimization function takes into account EV charging costs, revenue for V2G operations, and

wearing costs of BESS and EVs, by using the quadratic deviation of bought and sold power by the charging station as calculated in the first level. The chance constraints are added here to define the reserve levels required by BESS and EV batteries to compensate for the uncertainty due to the PV energy production. The results show that the use of the BESS as the only energy reserve for the utility grid does not significantly affect the charging schedule of the DC-connected charging station, whereas the use of both BESS and EV batteries as energy reserves decreases the operational costs of the charging station, even though revenues for the energy reserve service were not considered in the study.

The energy management of the MW charging station described in IV.C and shown in Fig. 11 has been implemented in [151]. Here, the goal is to reduce the grid impact due to the power required by the HD-EVs by exploiting a BESS. MILP optimization approach has been used in this case to reach the energy management scope. What is novel in this research work compared to other energy management algorithms is the modeling of the charging station through average models of the power converter and the consequent CHIL implementation.

A similar architecture is adopted in [184], but the SST is substituted by the typical solution with the inverter this time. Here, a three-level energy management strategy is used. The top level uses the weighted sum technique to solve an optimization function that aims to minimize charging time and cost every minute. In case this level is not able to provide a solution, a real-time state-machine-based optimization strategy with a 10 ms time step is used to replace it until a feasible solution is found. Finally, an MPC is used at the battery management level. The validation of this energy management strategy through CHIL shows a 28 % reduction of the total energy consumption from the grid.

2) Real-time optimization

A consecutive horizon-based energy management process was proposed in [185] to achieve the optimal technical and economical operation of DC-connected fast charging systems with integrated BESSs. A distributed control and a central supervisory control achieve the energy management of the fast charging stations. Moreover, active and reactive power control has been performed to comply with the grid codes. A Volt/VAr control is also used to limit the voltage deviations from the horizon-based predictions. Finally, such an energy management strategy achieved good results in terms of energy price reduction at the fast charging stations.

A novel EV charging station consisting of level 1, 2, and 3 EV chargers with vehicle-to-vehicle (V2V) capabilities was proposed in [186] to combine different EV chargers in urban areas. A three-stage scheduling framework based on stochastic mixed-integer linear programming (MILP) and model predictive control (MPC) was developed for such charging stations, which means that both a global and a

real-time optimization approach have been used. Moreover, the fast charging schedule of this hybrid charging station was performed by means of V2V, M/G/ ∞ queuing theory, and the most laxity first strategy. This kind of EMS was able to reduce both the grid aggregator's costs and slow-charging costs. The latter is reduced because the slow-charged vehicles are discharged during the peak demand towards the fast chargers to support the grid. Moreover, it improves the QoS by providing fast charging service to 20 % of the EV fleet.

A multi-layer energy management framework was developed in [187] for a DC-connected fast charging system with a PV unit, BESSs, and three 350 kW chargers. The purpose of such an approach is to minimize the operational costs and maximize the earnings of the charging station, taking into account the energy arbitrage, charging demand, and BESS degradation. The EMS approach shown in the paper is divided into three layers. The first one simulates the power imported from the grid, the electricity price, and the PV power generation of the next month, taking into account the same data over the last month. The second one uses a rolling horizon-based MILP approach to exploit the energy arbitrage, reduce the demand charge, and calculate the BESS life degradation over the long-term forecasts (between 6 and 48 hours) of the fast charging station loads, the electricity price, and the PV generation. The third one implements a convex decreasing horizon MPC to control the SoC of the BESS, to keep the desired power imported from the grid, and to exploit the BESS as a power buffer, with the short-term forecasts (1-15 minutes) of the fast charging station loads and PV power generation. Finally, this paper calculates the quantity of BESS which has to be used as an energy reserve.

3) Deterministic rule-based

The paper [158] was discussed in Section IV.D. It not only provides a novel architecture for a DC-connected fast charging system but also proposes an EMS to control the energy exchange and to allocate the BESSs to one of the other system components through the existing switching matrices. Some constraints are taken in the allocating algorithm. For example, the switching matrices allow direct connection only between the system components and the BESSs. This means that the energy produced by PVs must be first stored in a BESS, and only then can it be delivered to the grid. Moreover, the charging service must be guaranteed to all the incoming EVs, and the EVs must be connected until the end of their scheduled charge. The algorithm proposed in this paper was compared to a base algorithm and showed better results in satisfying the energy demand and enabling the self-sufficiency of the system. Furthermore, fewer cycles were required from the BESSs, which improved the battery lifetime. Moreover, the algorithm also leads to a low SoC of the BESSs during winter, which shall also reduce the calendar fading rate of the battery [201].

A discrete-event control-based supervisory control was developed in [188] for a DC-connected fast charging system with an integrated BESS and a PV unit. Such a control was able to limit the power exchanged with the grid according to the grid requirements. It kept its SoC within desirable limits, eventually supplying power to the upper grid when there is extensive energy production from the PV unit, and provides ancillary services such as reactive power compensation, voltage and frequency regulation, and power factor correction.

An algorithm that aims to reduce the peak demand in a DC-connected fast charging system with RESs and BESS was proposed in [189]. Such an algorithm reduced the instant power demand of a 100 kW DC-connected fast charging system with two EVs by 45 %. Moreover, this study was conducted with real data about the weather conditions and EV charging demand.

The connection of home PV units to DC fast charging stations is proposed in [190] to support the PV units. PV units are, in fact, affected by intermittent power generation, and BESSs are usually adopted to solve this problem. However, the proposed approach takes advantage of EV batteries and DC-connected fast charging systems to solve this problem in a more economical way. An EMS is developed to guarantee the efficient operation of the system. The EVs are charged during the peak power generation of the PV units, and they are discharged towards the home or the grid during the peak time demand and/or low energy production from the PV units.

Another rule-based approach was proposed in [191] for a DC-connected fast charging system including a PV unit, a BESS, and three 50-kW chargers to regulate the power flow between the different system components and to reduce the power imported from the grid. The control hardware in the loop (CHIL) approach was used for the real-time simulation of the system. Moreover, two different scenarios were considered to prove the rule-based approach: a limitless grid and a limited grid.

A study case of a grid-independent fast charging station in Qatar has been studied in [192]. The grid independence for this case of study has been reached by employing a 480 kWp concentrated photovoltaic thermal plant, a 250 kW wind turbine, a 10 kW biofuel generator, 585 kWh BESS, and 880 kWh of hydrogen and ammonia energy storage systems. This kind of fast charging station can provide daily service to 50 EVs all over the year.

4) Non-deterministic rule-based

An EMS based on the fuzzy logic control was proposed in [193] for a DC-connected fast charging system with a 100-kW PV unit, 100-kW wind turbines, and grid connection. The purpose of such an EMS was to manage the V2G and G2V operation of the EVs connected to the fast charging station, taking into account their SoC, battery capacity, and

time during which each EV is parked in the charging slot. The fuzzy logic control is applied to every charger, and an upper centralized controller collects the data about power generation and batteries' SoC and determines the power set point for each EV.

VI. CYBERSECURITY

The main cybersecurity problems that can affect DC fast charging stations are reviewed in this section. Sensible data of customers, EVs, and electric vehicle supply equipment (EVSE) can be damaged by hackers and cyberattacks. Theft of money, damages to the EVs and to the DC fast charging infrastructure, and death of the EV owner are among the possible impacts of such attacks. For this reason, the aim of this section is to first understand what are the sensible data and equipment that a cyberattack can potentially damage. Then, the possible threats common to all kinds of charging stations will be analyzed. Finally, some considerations about cybersecurity issues in DC fast charging stations will be discussed. The cyber architecture of a DC fast charging station is illustrated in Fig. 14.

A. OCPP PROTOCOL

The standard commonly used in charging communication is the open charge point protocol (OCPP). OCPP versions until 1.6 did not provide security functions [202], [205]. However, OCPP 2.0 was developed in 2018 to introduce security features, whereas OCPP 2.0.1 is the latest version created to fix some issues related to OCPP 2.0. OCPP 2.0.1 provides security communication through the transport layer security (TLS), security logging, event notification, security profiles for authentication, and secure firmware updates [206]. OCPP 2.0 also supports ISO 15118 for EVSE-to-EV communication and V2G communication [203], [207].

B. SECURITY ASSETS

Considering the relevant works on cybersecurity [202], [204], [207], [208], this paper divides the security assets into functional assets, financial and privacy assets, and safety assets:

- 1) The functional assets are those assets that would compromise the normal operation of the charging process in case of attack. The main functional assets that hackers can target are EV, EVSE, charging station, and power grid.
- 2) The financial and privacy assets refer to the financial status of customers and charging stations as well as the private information of the customers. The energy can be counted in these assets as well because energy theft leads to financial damage for both charging stations and customers.
- 3) The safety asset concerns the customers, and it is related to attacks that could threaten their lives. For example, if electrical protections are altered via a

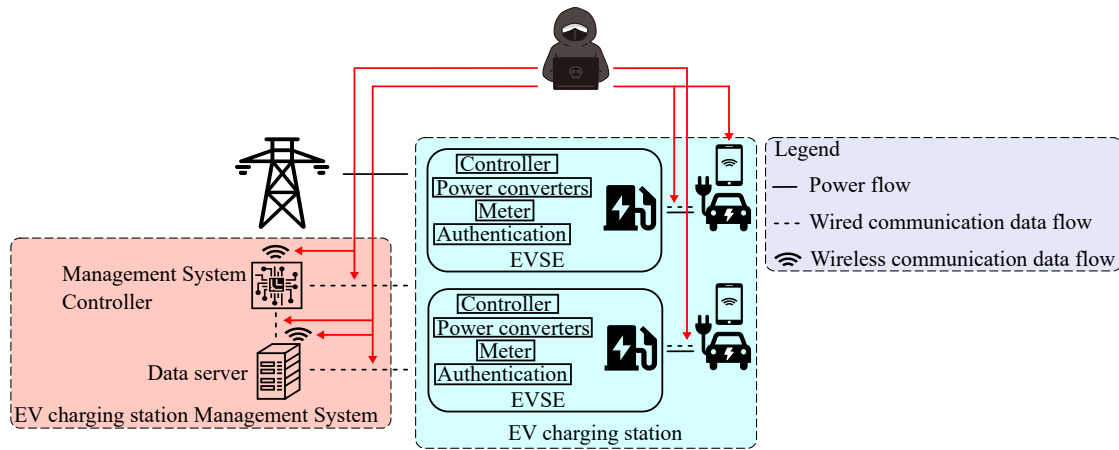

FIGURE 14: Cyber architecture of a DC fast charging station.

TABLE 10: Security assets targeted by the main cyberattacks threatening electric vehicle charging stations [202]–[204]

Attack	Functional assets				Financial and privacy asset			Safety asset
	EV	EVSE	Charging station	Power grid	Energy theft	Payment fraud	Privacy violation	
Tampering	●	●	●	●	●	●	●	●
MitM	●	●	●	○	●	●	●	○
Packet replay	●	●	●	○	○	●	●	○
DoS	●	●	●	●	○	●	●	○
FDIA	●	●	●	●	●	●	●	●
ARP spoofing	●	○	●	○	○	●	●	○
Malware	●	●	●	●	●	●	●	○

- : the asset is a target for that attack.
- : the asset is not a target for that attack.

cyberattack, this could lead to a dangerous situation for the EV owner.

C. THREATS

This subsection reviews the main attacks concerning EV charging based on the main studies in this field [202], [203], [208]–[210]. An understanding of cyberattacks is important when designing security measures in charging protocols like the already discussed OCPP 2.0.1. In the same way, the risk analysis of such attacks gives a better comprehension of their impact. A vulnerability analysis and risk assessment of different cyberattacks was presented in [211]. Hence, the following threats will take into account this distinction. The attacks described in this section and their targeted assets are summarized in Table 10.

1) Tampering attack

A tampering attack is perpetrated by interfering with the communication between the EV and the charging station or physically manipulating the charging infrastructure. In the first case, the hacker may tamper with the charging schedule to charge the EVs at peak hours, overloading the upper grid and changing the payment fee if the charging station offers a smart charging option [212]. In the second type of tampering attack, the hacker physically tampers the charging station, for example, by bypassing the authentication credentials of an EV driver [203] or by manipulating the modem through which the EVSE is connected to the target card reader, creating privacy issues and payment fraud attempts [203], [213]. A security strategy against message tampering attacks was proposed in [214]. Here, the EVs generate authentication parameters together with the charging requests, which are then delivered and elaborated by a central server to verify their authenticity. An advantage of this approach is that it can prevent message tampering attacks at low computational

costs, which is very important in EV charging communication since charging networks are usually not equipped with potent computational systems. An inference approach against tampering was proposed in [215] to establish the trustworthy devices and meters of a charging station by analyzing the changes in the measures of the primary supply point distribution meter and the smart meter connected to each charging pile.

2) Man-in-the-middle attack

In the man-in-the-middle (MitM) attack, the hacker intercepts the communication between the EV and the charging station, which enables the manipulation of the communication data. Over-charging/discharging to cause damages to the EV battery, privacy violation, and falsifying charging data for payment fraud are the main issues deriving from the MitM attack [216]. The MitM attack can also be perpetrated with a physical approach by using a fake cable or fake charger to interface the EV. In this case, the hacker does not interfere with the communication interface between the EV and the charging station [208]. A security strategy to protect the smart meter's data against the violations perpetrated by the MitM attacks was developed in [217] and simulated using the software simulator of the OCPP protocol called *ocppjs*.

3) Packet replay or eavesdropping

A packet replay or eavesdropping attack intercepts the communication between the EV and the charging station to read, replay, and modify the data transmission [203], [211]. For this reason, a packet replay or eavesdropping attack threatens customer privacy and may lead to other active attacks, threatening the security of ID credentials and bank account details [208], [212]. The vulnerability of the physical layer of the CCS standard to wireless eavesdropping attacks was demonstrated in [218] with real-world experiments. In particular, design choices of the power-line communication (PLC) were exploited for such attacks.

4) Denial-of-service attack

The denial-of-service (DoS) attack prevents the customers from charging their EVs at the charging station. This attack can be perpetrated by blocking legitimate requests of charging [216] by physically manipulating the sensors of a charging station [203] or by sending several fake charging requests to the charging station to saturate its charging schedule [212]. Customers might be denied to charge during low demand hours, obliging them to charge their EVs during the peak demand time, causing unstable grid operations and even blackouts [209]. A work on the impact of the DoS attack was presented in [219]. Here, a microgrid comprising a DC fast charging station was simulated, and the DoS attack was perpetrated in the morning, obliging the EV owners to recharge their vehicles in the evening. The study shows

that this change in the charging habits of the customers leads to the overload of the line frequency transformer and to undervoltage of the bus voltage, which in turn reduces the lifetime of the transformer. Moreover, a novel work on the use of tiny machine learning (TinyML) in cybersecurity applications for the electric vehicle charging infrastructure was introduced in [220]. TinyML is used here against DoS and other common cyberattacks included in the CICIDS2017 dataset [221], [222]. This study highlights the reduction in terms of cost, computational time, memory usage, and energy consumption that TinyML is able to achieve when compared to traditional machine learning. The experimental validation through a low-power and low-cost ESP32 microcontroller also proves that TinyML improves security and privacy, and it can be integrated into the EV charging infrastructure not penalizing its cost.

5) False data injection attack

False data injection attacks (FDIAs) aim to send false messages to the charging station to manipulate the information coming from the smart meters. FDIAs may lead to energy theft, privacy issues, overcharging of EVs, and damages to the charging and grid infrastructure [203], [216]. A cybersecurity strategy based on the Kullback-Leibler divergence was implemented in [223] to reject FDIAs on the data market of a charging station. An evaluation of the impact of FDIAs on three different charging algorithms was presented in [224]. An FDIA detection method was proposed in [225] for a charging station using a supercapacitor and a multi-charger cooperative charging method. This detection algorithm includes using a Kalman filter for the current measures, a time-domain detection method, and a frequency-domain detection method.

6) Address resolution protocol spoofing attack

A hacker perpetrates the address resolution protocol (ARP) spoofing attack by sending fake ARP messages over the local area network of a charging station to get the IP address of a computer or server in the charging network and to associate it with its own MAC address. This would result in the theft of confidential information regarding both the charging station and the EV owner [203], [211]. This attack usually leads to a MitM, where the MitM node is the one that the hacker used for the ARP spoofing [203], [210].

7) Malware attack

Malware attacks may lead to the disclosure of sensitive information, payment fraud, and energy theft. Moreover, malware may be passed through the charging station to the EVs and power grid, making security issues more concerning [203], [208], [216].

D. ANALYSIS OF THE IMPACT OF CYBERATTACKS ON THE GRID AND EVSE

The recent literature on cybersecurity attacks has considered their impact on the power grid and on the EVSE using analytical approaches. In particular, it is possible to divide this kind of studies based on the area affected by the cyberattacks. Macroanalysis deals with the effects of cyberattacks on wide areas, like cities or towns, and usually uses power flow approaches and test grids or real grid scenarios to validate the study. On the other hand, microanalysis is related to the effect of cyberattacks on the EVSE and the power electronics dedicated to the charging station. Moreover, studies regarding energy trading in EV charging stations are becoming popular to ensure secure and reliable transactions between service operators and EV owners.

The research works on the macroanalysis of the effects of cyberattacks on the power system gained interest since the cyberattack on the Ukraine power grid on 23 December 2015. An FDIA attack was perpetrated by combining phishing emails, a telephonic DoS attack, and a modified firmware attack on the workstations [226]. It is natural to presume that the spread of EVs and EV charging stations might give the perfect access point to hackers, who can seriously compromise the power system stability by manipulating high power loads such as EV batteries that are also capable of injecting power to the grid. On this regard, a data-driven cyberattack was studied in [227], where the customers' data were acquired from a smartphone application and the grid data from administrative sources, system operator, and local utility. It consists of a state-feedback-based partial eigenvalue relocation, targeting the frequency stability of the power grid. Here the power grid has been modeled with the DC power flow assumption, whereas the quantification of the effects of cyberattacks is given by the maximum relocation error:

$$\varepsilon = \|\hat{e}^p - \hat{e}^a\|_2, \quad (5)$$

where \hat{e}^a represents the target eigenvalues and \hat{e}^p represents the two post-attack eigenvalues that are closest to \hat{e}^a . A very high error denotes that the attack did not have a high impact or that was even unsuccessful, whereas a very small error indicates that the attack was able to destabilize the grid. Even though such a kind of attack is not considered enough to make the grid unstable, the increasing penetration of EVs might lead to a serious threat to the power system stability in the coming years. Another kind of cyberattack with serious consequences for the grid is the so-called switching attack, that occurs when an hacker gets control of switching elements such as circuit breakers or switches and applies a control strategy to them to destabilize the grid [228], [229], for example as the result of a MitM attack. A two-stage protection method was developed in [230] against such a cyberattack. It is made of a back propagation neural network (BPNN) that detects and mitigates the switching attack and a H^∞ control that keeps the grid stable in case of failure of the BPNN. Such a defense strategy was also tested

on a two-area Kundur grid and on a five-area Australian grid. Another study on the grid impact of EV charging station was given in [231]. Here, EV charging stations are proved to be more dangerous than traditional loads in case of cyberattacks because of their higher reactive power demand, which facilitates the destabilization of the grid. Moreover, the research work shows the grid frequency and voltage deviations in case of cyberattacks causing the power injection from EV charging stations and switching attacks. Blackouts and damage to the generators and transformers are the direct consequences of such attacks.

Moving now the discussion on the microanalysis, the focus shifts on the effects of cyberattacks on the EVSE and power conversion devices of the EV charging stations. Apart from the lack of service for the EV owners, the power converters and EVSE might be seriously damaged or permanently compromised by this kind of attacks. A first example of research work in this regard is a deep-learning-based intrusion detection system based on long short-term memory [232]. The paper modeled an isolated EV charging station with a PV unit, a BESS, and a boost converter as charging unit. The paper also provides an analytical model of an FDI attack and a DoS attack. The results show that the PV unit output voltage is affected by oscillations, and there are no visible effects on the BESS for both the cyberattacks, whereas the output voltage of the EV charging unit demonstrates irreversible DC shift after the FDI attack and it is not affected by the DoS attack.

Another study involving the power converter modeling, but related to a 100 kW wireless power transfer (WPT) charging station, was addressed in [233]. The WPT charging station is made of a three-phase PWM rectifier, a buck converter, and a resonant converter with a secondary side located inside the car and directly connected to the EV battery. Possible attacks that have physical consequences for the power converters of such a system are hacking the grid side controllers, introducing a fake communication between the vehicle and the WPT charging station, and manipulating the BMS of the EV being charged. The consequence can be either a short-circuit in one of the converters or a fault due to the manipulation of the BMS. In particular, if the battery contactor opens before the charging is over, the resonant converter could be damaged by overvoltage. These problems were mitigated by introducing a desaturation protection circuitry to prevent damages due to short circuits and an LLC-series compensation topology to reduce the overvoltage in the case the battery contactor prematurely opens.

Shifting the focus on the consequences of cyberattacks on the energy management of an EV charging station, [234] studied the impact of hijacking (equivalent to the MitM attack) and an FDIA attack. Respectively, the first one modifies the charging time communicated to the charging system operator, which can cause overcharging of the EV battery of delayed service for other customers, whereas the second one modifies the power limits communicated by the

distribution system operator (DSO) to the charging system operators, exceeding in this way the actual power limits and destabilizing the upper grid.

Now that the macroanalysis and microanalysis of the effects of cyberattacks on the grid and EVSE have been discussed, some mitigation methods and energy trading approaches can be addressed. A hidden Markov model (HMM) that can predict and mitigate the effect of cyberattacks on DC fast charging stations was proposed in [235]. The HMM is defined by two stochastic processes. A hidden process uses a random variable to represent the transitions between states, and an observation process uses another random variable to represent the output of each state. A more popular energy trading approach to ensure secure transactions is represented by blockchain-based frameworks. An example of this kind of framework is given in [236]. Here, a contract-based incentive approach is used to reward customers based on the energy provided to the grid. Moreover, edge computing is adopted to improve the computational power of the system and the probability of success of the energy trades. Other examples of blockchain-based energy trading are provided in [237], [238] to enable V2G operations. A double auction mechanism is used in these works to allow the EV owners and the service provider to exchange information regarding the energy provided or required and the related price. Since this mechanism uses public ID to identify the users inside the blockchain, the privacy of the EV owner is preserved. The framework proposed in [238] is also secure against DoS attacks because each node is pre-authenticated and verified. Therefore, the intrusion of another node blocking the entire network is unlikely to occur.

This subsection has discussed the analysis of the effects of cyberattacks from a macro and micro-perspective. From the macro-level point of view, power flow analysis and eigenvalue relocation of the power system model shown in [227] is the most promising way to study the effects of cyberattacks on wide areas such as cities or towns. Since it has been pointed out that the starting point for such attacks is given by publicly available customers' and grid data, serious efforts are demanded from both cybersecurity algorithms and control strategies to keep the grid stable. On the other hand, cyberattacks on the EVSE are less likely to occur because they require knowledge about hardware and firmware and an access point to them. However, such attacks can also lead to more dangerous impacts by disabling the protections of the EVSE or causing short-circuits in the power converters. Fire and explosions can be considered as extreme consequences of such a kind of attack.

It is also important to mention that the research works focusing on the micro-level effects of cyberattacks do not provide a clear quantification of their impact, and major efforts are required to define an accurate methodology to analyze the problem. Furthermore, blockchain-based energy trading frameworks have shown their potential to ensure secure transactions between customers and energy providers

without any external entity. However, blockchains also require to solve mathematical problems to create a transaction, which requires a certain computational effort. Even though blockchains can generate transactions with less energy consumption than the one required by cryptocurrencies and can also be used in low power consumption fields such as the secure communication between internet of things (IoTs) devices [239], a feasibility assessment is necessary to understand their sustainability in the energy trading field.

E. CYBERSECURITY CONSIDERATIONS IN DC FAST CHARGING STATIONS

There are not many works dealing with cybersecurity issues specifically in DC fast charging stations because cyberattacks and security strategies are usually common to AC and DC charging. However, it is important to notice that the different technology of DC fast charging stations, particularly DC-connected ones, might lead to new kinds of attacks in the future. For example, protection devices and sensors are different in DC-connected fast charging stations, and manipulating them could be extremely dangerous considering that the fault current can reach hundreds of amps in less than two milliseconds in DC systems [240].

A report about the cybersecurity of extremely fast charging stations by Idaho National Laboratory, APS Global, and XOS Trucks was done in [241] for ABB Inc. Here, three possible attack scenarios are analyzed. The first one is the manipulation of the output current metering of the fast charger and/or the SoC of the EV battery, which may lead to its over- or under-charging. The second one is to fabricate low current measurements when all the charging spots are occupied, and the real current value is high. Because of this attack, the charging station might decide to charge the BESS, triggering the overloading protection. Finally, the last attack scenario is in making it appear that more chargers are occupied than the actually used ones. In this case, the charging station might decide to discharge the BESS without a real need, causing a money loss for the charging operator. Moreover, the report presents a novel resilient control architecture to increase the cybersecurity of DC fast charging stations. Another work dealing specifically with cybersecurity of DC fast charging stations was shown in [242], where an emulation environment for cyberattacks was described.

Even though the cybersecurity issues related to DC fast charging stations have not been widely covered yet, their high power technology raises concerns about possible micro-level cyberattacks. As discussed in the previous subsection, micro-level attacks are the least likely to occur because the hacker needs knowledge and access to hardware and firmware to start the attack. However, such attacks are also the ones with the most severe consequences, because manipulation of the protection circuitry and short-circuit in power converters can lead to fire and explosions, impacting the personal safety of the customers.

VII. DISCUSSION AND FUTURE TRENDS

The growing number of EVs will have a huge impact on everyday life, and it is important to implement the related charging infrastructure in the most sustainable and future-proof way. DC fast charging stations are a key point in this scenario. The way to implement DC fast charging stations in the most efficient and sustainable way is to think about their design and implementation from different points of view, including the different features that have been addressed in this paper: standards, power conversion technologies, architectures, energy management, and cybersecurity. Regarding the standards, CCS and NACS are the ones becoming more popular and are expected to be dominant in the near future. Moreover, the introduction of MCS opens the prospect of MW charging stations for HD-EVs. However, it is still unclear how to deal with the grid impact raised by this kind of system. Another important point is the introduction of 800 V EVs, which creates the need for future-proof power converters that are able to interface a wide output voltage range. HD-EVs must also be considered in this discussion because of their high-voltage batteries. Their trend is expected to move towards 1000 V batteries as for Tesla Semi. For these reasons, traditional topologies like the DAB converter could soon be replaced by emerging topologies such as the ones discussed in subsections III.E and III.F.

Furthermore, DC-connected fast charging stations are expected to be dominant due to their increased efficiency and lower number of power converters. Looking at the solutions proposed by Tritium and Enercon, the future DC-connected fast charging stations are expected to be radial and unipolar, which implies simple and cheap, but also less resilient, architectures. Architectures based on SST are instead not expected to be used in the next years because their economic advantage only comes with high penetration of renewable resources and wide adoption of V2X technologies. Yet, as explained in subsection IV.F, IEC 61851-23 [68] clearly states that isolation must be provided for each output in DC fast charging stations with multiple outputs if such outputs operate at the same time. Since implementing isolation from the grid via a low-frequency transformer for every charging port would be quite expensive, it is expected that the future DC-connected fast charging stations will be equipped with isolated DC-DC converters connected to a shared high-power AC-DC converter. Moreover, a switching matrix could be implemented between a group of converters and output ports to provide different levels of charging speeds, i.e., different levels of service in a corresponding business model. However, this paper also addressed non-isolated solutions because the standards might change in the future, as it happened in the PV world, where once the DC-DC converters were usually isolated, and now they are typically transformerless. Keeping this discussion going is important to minimize the cost of EV charging infrastructure, while safety concerns must be fully addressed first. Nonetheless, we expect that isolation topologies will be the only viable solution for the

industry in the foreseeable future due to their compliance with the existing standards.

Besides, RESSs, BESSs, and energy management strategies are expected to further improve the sustainability of DC fast charging stations, reduce the grid impact, and provide ancillary services, specifically voltage and frequency regulation, and energy reserves. Among the energy management approaches, global optimization and deterministic rule-based strategies are the most used in literature. In particular, MILP and state-machine-based strategies are the most common ones, and they are feasible enough to be demonstrated using HIL and CHIL implementations. Real-time simulations are getting popular in high power systems such as DC fast charging stations because they allow to reduce time to market and implementation costs. In this specific case, real-time simulations can be used to simulate low-level power converter control and high-level energy management strategies. One important issue in common with most of the energy management works is that they do not usually refer to the power electronics adopted by DC fast charging stations. In particular, none of the reviewed papers has realized an optimization function taking into account the converter efficiency for different EV powertrains, respectively 400 V or 800 V. Yet, no paper has verified the behavior of a particular energy management system in power hardware in the loop (PHIL) environment with a specific power converter as hardware under test. Lack of standardized testing in this field makes difficult to benchmark power converters and energy management strategies as for PV inverters and MPPT algorithms [243]. Therefore, some efforts are needed to unify the various aspects of DC fast charging stations, and the energy management strategies shown in this review might still be several years away from practical realization.

Last, but not least, DC fast charging stations include a cyber layer that cannot be neglected due to security issues. Regarding macro-areas such as cities and towns, future research activities on power flow analysis like in [227] are expected to predict and quantify the effects of cyberattacks perpetrated on DC fast charging stations on the entire power grid. Moreover, this kind of attack is expected to be more likely to happen since the only information needed is publicly available customers' and grid data. From a micro-level point of view, no research work has proposed a proper quantification for the effects of cyberattacks on DC fast charging stations and EVSE. However, it is possible to say that these kinds of attacks are less likely to occur because they require knowledge about the hardware and firmware of the charging station. On the other side, they are more severe because they can cause short-circuits of the power electronic converters and disable the protection devices. Finally, recent research works showed that blockchain-based frameworks are the future trend for secure transactions in EV charging stations. However, their sustainability should be proven before a real implementation because the creation of a transaction in the blockchain requires the solution of a

mathematical problem, which in turn requires computational effort.

VIII. CONCLUSION

The fast adoption of EVs opens new challenges that the government, companies, and researchers must address. For this reason, this paper reviewed some of the main research points in the field. First of all, an overview of DC fast charging standards, EV powertrains, and current development of EV fast chargers has been discussed. Here, it has been highlighted that DC networks and microgrids are promising architectures for fast charging stations because they allow for increased efficiency, decreased number of power converters, and reduced running costs. However, the lack of standards for protection and metering has limited the employment of DC-connected fast charging stations, which are actually a minority in the market.

Then, the main converter topologies adopted in DC fast charging stations and the emerging solutions to interface both 400 V and 800 V batteries have been described. The market presence of several EV powertrains complicates the design of fast chargers due to the need for a very wide battery charging voltage range. Among the emerging topologies, PPCs have been highlighted because of their increased efficiency and reduced implementation costs, which, however, require the DC bus to match the EV battery voltage as closely as possible to exploit all the benefits of these converters. Among the galvanically isolated DC-DC converters, there is a recent trend of implementing 3-port converters capable of connecting two output ports in series and parallel to achieve the 200-1000 V battery charging voltage range.

Moreover, the main architectural features of DC-connected fast charging stations have been analyzed because of their potential to become the backbone infrastructure of future fast charging systems. In particular, radial and ring configurations, and unipolar and bipolar architectures have been explained, considering their advantages and disadvantages in the design of a DC-connected fast charging station. It could be concluded that radial unipolar DC-connected fast charging systems provide the simplest and cheapest implementation. The new concept of MW charging stations for HD-EVs has also been discussed. Current issues of such systems are their grid impact and their architectural features. Even though SST is a promising solution to offer ancillary services in MW charging stations, its economic viability must be investigated during the design stage. In addition, the use of BESS in DC-connected fast charging stations and the case study of DC-connected fast charging stations into traction grids have also been discussed. BESSs provide numerous additional services to the customers and ancillary services to the grid, enabling emerging business models for fast charging station operators. Safety, protection, and isolation requirements have also been studied. Here, one of the main points to underline is that DC fast charging stations equipped with multiple ports operating at the same time require isolation per each port

according to IEC 61851-23 [68]. This means that isolated DC-DC converters will likely be the dominant choice in the future unless there is a change in the current standards.

Furthermore, energy management approaches for DC fast charging stations have been classified, taking into account their main goals and their optimization algorithms. Optimization-based strategies dominate the research literature. On the other hand, rule-based strategies were demonstrated for realistic case studies of fast EV charging stations.

Finally, the main cybersecurity issues common to all charging systems have been addressed, and some specific cases regarding DC fast charging stations have been considered to give a complete perspective of the research points in the field of DC fast charging of EVs. Generally speaking, forthcoming versions of EV charging protocols target much-improved cybersecurity provisions, like integrating ISO 15118-20 standard in CCS 2.0 to replace the unsecured DIN 70121 powerline communication protocol. The newest version of the Open Charge Point Protocol (OCPP 2.0.1) also supports ISO 15118-20. Yet, the effects of cyberattacks on grid and charging stations have been considered from a macro and micro-level point of view. Cybersecure architectures have been reviewed as well, highlighting that blockchain-based frameworks are the future trend in this field. Hence, cybersecurity issues would be one of the main obstacles to the widescale deployment of fast charging stations and, thus, require more attention from developers of equipment.

REFERENCES

- [1] "Electric car registrations and sales share in china, united states, europe and other regions, 2016-2021." International Energy Agency (iea). [Online]. Available: <https://www.iea.org/data-and-statistics/charts/electric-car-registrations-and-sales-share-in-china-united-states-europe-and-other-regions-2016-2021>.
- [2] H. Zhang and J. Zhang, "An overview of modification strategies to improve $\text{LiNi}_{0.8}\text{Co}_{0.1}\text{Mn}_{0.1}\text{O}_2$ (ncm811) cathode performance for automotive lithium-ion batteries," *eTransportation*, vol. 7, p. 100105, 2021.
- [3] A. Tomaszewska, Z. Chu, X. Feng, S. O'kane, X. Liu, J. Chen, C. Ji, E. Endler, R. Li, L. Liu, *et al.*, "Lithium-ion battery fast charging: A review," *eTransportation*, vol. 1, p. 100011, 2019.
- [4] P. Qin, J. Sun, X. Yang, and Q. Wang, "Battery thermal management system based on the forced-air convection: A review," *eTransportation*, vol. 7, p. 100097, 2021.
- [5] X. Lai, Q. Chen, X. Tang, Y. Zhou, F. Gao, Y. Guo, R. Bhagat, and Y. Zheng, "Critical review of life cycle assessment of lithium-ion batteries for electric vehicles: A lifespan perspective," *eTransportation*, vol. 12, p. 100169, 2022.
- [6] W. Yu, Y. Guo, Z. Shang, Y. Zhang, and S. Xu, "A review on comprehensive recycling of spent power lithium-ion battery in china," *eTransportation*, vol. 11, p. 100155, 2022.
- [7] "Charging — tesla support." Tesla. [Online]. Available: <https://www.tesla.com/support/charging>.
- [8] "Fast publicly available chargers, 2015-2021." International Energy Agency (iea). [Online]. Available: <https://www.iea.org/data-and-statistics/charts/fast-publicly-available-chargers-2015-2021>.
- [9] T. Unterluggauer, J. Rich, P. B. Andersen, and S. Hashemi, "Electric vehicle charging infrastructure planning for integrated transportation and power distribution networks: A review," *eTransportation*, vol. 12, p. 100163, 2022.
- [10] M. Yilmaz and P. T. Krein, "Review of battery charger topologies, charging power levels, and infrastructure for plug-in electric and

- hybrid vehicles," *IEEE transactions on Power Electronics*, vol. 28, no. 5, pp. 2151–2169, 2012.
- [11] G. Rajendran, C. A. Vaithilingam, N. Misron, K. Naidu, and M. R. Ahmed, "A comprehensive review on system architecture and international standards for electric vehicle charging stations," *Journal of Energy Storage*, vol. 42, p. 103099, 2021.
- [12] M. Safayatullah, M. T. Elrais, S. Ghosh, R. Rezaei, and I. Batarseh, "A comprehensive review of power converter topologies and control methods for electric vehicle fast charging applications," *IEEE Access*, vol. 10, pp. 40753–40793, 2022.
- [13] S. Rivera, S. Kouro, S. Vazquez, S. M. Goetz, R. Lizana, and E. Romero-Cadaval, "Electric vehicle charging infrastructure: From grid to battery," *IEEE Industrial Electronics Magazine*, vol. 15, no. 2, pp. 37–51, 2021.
- [14] H. Tu, H. Feng, S. Srdic, and S. Lukic, "Extreme fast charging of electric vehicles: A technology overview," *IEEE Transactions on Transportation Electrification*, vol. 5, no. 4, pp. 861–878, 2019.
- [15] S. Srdic and S. Lukic, "Toward extreme fast charging: Challenges and opportunities in directly connecting to medium-voltage line," *IEEE Electrification Magazine*, vol. 7, no. 1, pp. 22–31, 2019.
- [16] S. Valedsaravi, A. El Aroudi, and L. Martínez-Salamero, "Review of solid-state transformer applications on electric vehicle dc ultra-fast charging station," *Energies*, vol. 15, no. 15, p. 5602, 2022.
- [17] L. Wang, Z. Qin, T. Slangen, P. Bauer, and T. Van Wijk, "Grid impact of electric vehicle fast charging stations: Trends, standards, issues and mitigation measures-an overview," *IEEE Open Journal of Power Electronics*, vol. 2, pp. 56–74, 2021.
- [18] M. A. H. Rafi and J. Bauman, "A comprehensive review of dc fast-charging stations with energy storage: Architectures, power converters, and analysis," *IEEE Transactions on Transportation Electrification*, vol. 7, no. 2, pp. 345–368, 2020.
- [19] H. Muhedinovic, "Preparing the way ahead for a compatible ev infrastructure." Vicor Corporation. 2021. [Online]. Available: <https://www.vicorpower.com/resource-library/articles/automotive/prepari-ng-compatible-ev-infrastructure>.
- [20] A. Ahmad, Z. Qin, T. Wijekoon, and P. Bauer, "An overview on medium voltage grid integration of ultra-fast charging stations: Current status and future trends," *IEEE Open Journal of the Industrial Electronics Society*, vol. 3, pp. 420–447, 2022.
- [21] N. S. Pearre and H. Ribberink, "Review of research on v2x technologies, strategies, and operations," *Renewable and Sustainable Energy Reviews*, vol. 105, pp. 61–70, 2019.
- [22] A. Alsharif, C. W. Tan, R. Ayop, A. Dobi, and K. Y. Lau, "A comprehensive review of energy management strategy in vehicle-to-grid technology integrated with renewable energy sources," *Sustainable Energy Technologies and Assessments*, vol. 47, p. 101439, 2021.
- [23] A. Golder and S. S. Williamson, "Energy management systems for electric vehicle charging stations: A review," in *IECON 2022–48th Annual Conference of the IEEE Industrial Electronics Society*, pp. 1–6, IEEE, 2022.
- [24] "High power (chaoji)." CHAdEMO. [Online]. Available: <https://www.chademo.com/technology/high-power>.
- [25] "Opening the north american charging standard." Tesla. 2022. [Online]. Available: https://www.tesla.com/en_eu/blog/opening-north-american-charging-standard.
- [26] G. Arena, P. Emiliani, A. Chub, D. Vinnikov, and G. De Carne, "Dc fast charging of electric vehicles: a review on architecture and power conversion technology," in *2023 IEEE 17th International Conference on Compatibility, Power Electronics and Power Engineering (CPE-POWERENG)*, pp. 1–6, IEEE, 2023.
- [27] "Wall connector, 80a single phase installation manual." Tesla. [Online]. Available: <https://www.tesla.com/sites/default/files/pdfs/wall-connector-eu/tesla-80a-wall-connector-installation-manua-en-v1.pdf>.
- [28] "Charin whitepaper megawatt charging system (mcs)." CharIN. [Online]. Available: https://www.charin.global/media/pages/technology/knowledge-base/c708ba3361-1670238823/whitepaper_megawatt_charging_system_1.0.pdf.
- [29] L. Schriewer and D. Reichert, "Vehicle-to-grid: Quo vadis? readiness check of the technology landscape for integrating electric vehicles into the smart grid," in *Der Antrieb von morgen 2021* (J. Liebl, ed.), (Berlin, Heidelberg), pp. 251–262, Springer Berlin Heidelberg, 2021.
- [30] I. Aghabali, J. Bauman, P. J. Kollmeyer, Y. Wang, B. Bilgin, and A. Emadi, "800-v electric vehicle powertrains: Review and analysis of benefits, challenges, and future trends," *IEEE Transactions on Transportation Electrification*, vol. 7, no. 3, pp. 927–948, 2020.
- [31] C. Jung, "Power up with 800-v systems: The benefits of upgrading voltage power for battery-electric passenger vehicles," *IEEE Electrification Magazine*, vol. 5, no. 1, pp. 53–58, 2017.
- [32] "Terra 94 to 184 ul product guide." ABB. [Online]. Available: https://library.e.abb.com/public/729adbdc0074b119230d954220aa907/Terra-94-124-184_UL_Product-Guide_B.pdf?x-sign=Zmhcu+REdiEuD5cbrCj2fmKfCzYvPfoYS4XZGpO0oyhigegO1GiRyVJruZIEhtP.
- [33] "Phihong ev chargers - 2020-2021 ev charging solution." https://www.hn-electronic.de/pdf/ev/2020-21_EV_Chargers_EN.pdf, accessed 2023-01-23.
- [34] "Tritium pk150 - product specifications." Tritium. 2022. [Online]. Available: <https://tritiumcharging.com/wp-content/uploads/2022/01/PKM150-Data-Sheet.pdf>.
- [35] "Tritium nevi system - webpage." Tritium. [Online]. Available: <https://tritiumcharging.com/product/nevi-150/>.
- [36] "Enercon e-charger 600." Enercon 2018. [Online]. Available: https://www.enercon.de/fileadmin/Redakteur/Service/EC_E-Charger_600_en_web.pdf.
- [37] "Enercon smart solution - bausteine der sektorenkopplung für ein dezentrales ee-system -." Enercon 2018. [Online]. Available: https://www.unendlich-viel-energie.de/media/file/2281.Enercon_Rueppel.pdf.
- [38] Z. Zhang, H. Xu, L. Shi, D. Li, and Y. Han, "A unit power factor dc fast charger for electric vehicle charging station," in *Proceedings of The 7th International Power Electronics and Motion Control Conference*, vol. 1, pp. 411–415, IEEE, 2012.
- [39] B. Wu, H. Chen, G. Guan, T. Ding, and L. Yin, "Simulation model of three-phase pwm rectifier charging station and harmonic analysis on grid," in *2017 IEEE Innovative Smart Grid Technologies-Asia (ISGT-Asia)*, pp. 1–6, IEEE, 2017.
- [40] Z. Yingchao, L. Jiangtao, G. Wei, L. Yang, and Z. Bo, "Implementation of high efficiency batteries charger for ev based on pwm rectifier," in *2012 IEEE Vehicle Power and Propulsion Conference*, pp. 1525–1528, IEEE, 2012.
- [41] D. Aggeler, F. Canales, H. Zelaya-De La Parra, A. Coccia, N. Butcher, and O. Apeldoorn, "Ultra-fast dc-charge infrastructures for ev-mobility and future smart grids," in *2010 IEEE PES Innovative Smart Grid Technologies Conference Europe (ISGT Europe)*, pp. 1–8, IEEE, 2010.
- [42] A. Arancibia and K. Strunz, "Modeling of an electric vehicle charging station for fast dc charging," in *2012 IEEE International Electric Vehicle Conference*, pp. 1–6, IEEE, 2012.
- [43] G. Zhemerov, O. Plakhtii, and A. Mashura, "Efficiency analysis of charging station for electric vehicles using the active rectifier in microgrid system," in *2020 IEEE 4th International Conference on Intelligent Energy and Power Systems (IEPS)*, pp. 37–42, IEEE, 2020.
- [44] R. Evode, "Modeling of electric grid behaviors having electric vehicle charging stations with g2v and v2g possibilities," in *2021 International Conference on Electrical, Computer, Communications and Mechatronics Engineering (ICECCME)*, pp. 1–5, IEEE, 2021.
- [45] G. B. Sahinler and G. Poyrazoglu, "V2g applicable electric vehicle chargers, power converters & their controllers: A review," in *2020 2nd Global Power, Energy and Communication Conference (GPECOM)*, pp. 59–64, IEEE, 2020.
- [46] A. Nabae, I. Takahashi, and H. Akagi, "A new neutral-point-clamped pwm inverter," *IEEE Transactions on industry applications*, no. 5, pp. 518–523, 1981.
- [47] N. Celanovic and D. Boroyevich, "A comprehensive study of neutral-point voltage balancing problem in three-level neutral-point-clamped voltage source pwm inverters," *IEEE Transactions on power electronics*, vol. 15, no. 2, pp. 242–249, 2000.
- [48] L. Tan, B. Wu, V. Yaramasu, S. Rivera, and X. Guo, "Effective voltage balance control for bipolar-dc-bus-fed ev charging station with three-level dc-dc fast charger," *IEEE Transactions on Industrial Electronics*, vol. 63, no. 7, pp. 4031–4041, 2016.
- [49] S. Rivera, B. Wu, S. Kouro, V. Yaramasu, and J. Wang, "Electric vehicle charging station using a neutral point clamped converter with bipolar dc bus," *IEEE transactions on Industrial Electronics*, vol. 62, no. 4, pp. 1999–2009, 2014.
- [50] Y. Zhang, L. Jin, Y. Jing, Z. Zhao, and T. Lu, "Three-level pwm rectifier based high efficiency batteries charger for ev," in *2013 IEEE*

- Vehicle Power and Propulsion Conference (VPPC)*, pp. 1–4, IEEE, 2013.
- [51] N. Soualhi, A. Makouf, N. Nait-Said, and S. Hamada, “Comparison between a two-level and three-level inverter fed induction motor including losses and efficiency,” in *2020 4th International Conference on Advanced Systems and Emergent Technologies (IC_ASET)*, pp. 89–94, IEEE, 2020.
- [52] A. Kersten, E. Grunditz, and T. Thiringer, “Efficiency of active three-level and five-level npc inverters compared to a two-level inverter in a vehicle,” in *2018 20th European Conference on Power Electronics and Applications (EPE'18 ECCE Europe)*, pp. P–1, IEEE, 2018.
- [53] A. Choudhury, P. Pillay, M. Amar, and S. S. Williamson, “Performance comparison study of two and three-level inverter for electric vehicle application,” in *2014 IEEE Transportation Electrification Conference and Expo (ITEC)*, pp. 1–6, IEEE, 2014.
- [54] A. Madan and E. Bostanci, “Comparison of two-level and three-level npc inverter topologies for a pmsm drive for electric vehicle applications,” in *2019 International Aegean Conference on Electrical Machines and Power Electronics (ACEMP) & 2019 International Conference on Optimization of Electrical and Electronic Equipment (OPTIM)*, pp. 147–154, IEEE, 2019.
- [55] J. W. Kolar and F. C. Zach, “A novel three-phase utility interface minimizing line current harmonics of high-power telecommunications rectifier modules,” *IEEE Transactions on Industrial Electronics*, vol. 44, no. 4, pp. 456–467, 1997.
- [56] J.-S. Lee and K.-B. Lee, “A novel carrier-based pwm method for vienna rectifier with a variable power factor,” *IEEE Transactions on Industrial Electronics*, vol. 63, no. 1, pp. 3–12, 2015.
- [57] W. Ding, C. Zhang, F. Gao, B. Duan, and H. Qiu, “A zero-sequence component injection modulation method with compensation for current harmonic mitigation of a vienna rectifier,” *IEEE Transactions on Power Electronics*, vol. 34, no. 1, pp. 801–814, 2018.
- [58] J.-M. Kim, J. Lee, T.-H. Eom, K.-H. Bae, M.-H. Shin, and C.-Y. Won, “Design and control method of 25kw high efficient ev fast charger,” in *2018 21st international conference on electrical machines and systems (ICEMS)*, pp. 2603–2607, IEEE, 2018.
- [59] S. Chen, W. Yu, and D. Meyer, “Design and implementation of forced air-cooled, 140khz, 20kw sic mosfet based vienna pfc,” in *2019 IEEE Applied Power Electronics Conference and Exposition (APEC)*, pp. 1196–1203, IEEE, 2019.
- [60] J. A. Anderson, M. Haider, D. Bortis, J. W. Kolar, M. Kasper, and G. Deboy, “New synergetic control of a 20kw isolated vienna rectifier front-end ev battery charger,” in *2019 20th Workshop on Control and Modeling for Power Electronics (COMPEL)*, pp. 1–8, IEEE, 2019.
- [61] F. Palomba, F. Gennaro, M. Pavone, N. Aiello, G. Aiello, and M. Cacciato, “Analysis of pcb parasitic effects in a vienna rectifier for an ev battery charger by means of electromagnetic simulations,” in *2019 21st European Conference on Power Electronics and Applications (EPE'19 ECCE Europe)*, pp. 1–10, IEEE, 2019.
- [62] R. Pandey and B. Singh, “An electric vehicle charger based on vienna rectifier and resonant llc converter,” in *2020 IEEE International Conference on Power Electronics, Drives and Energy Systems (PEDES)*, pp. 1–6, IEEE, 2020.
- [63] A. Saadaoui, M. Ouassaid, and M. Maaroufi, “Backstepping-based control of vienna rectifier for electric vehicle dc ultra-fast charger,” in *2022 IEEE 21st Mediterranean Electrotechnical Conference (MELECON)*, pp. 360–365, IEEE, 2022.
- [64] D. Cittanti, E. Vico, M. Gregorio, and R. Bojoi, “Design and experimental assessment of a 60 kw all-si three-phase six-leg t-type rectifier for electric vehicle ultra-fast charging,” in *2021 International Conference on Electrical, Computer, Communications and Mechatronics Engineering (ICECCME)*, pp. 01–08, IEEE, 2021.
- [65] S. Bayhan and H. Komurcugil, “A t-type converter-based electric vehicle charger with active power filter functionality,” in *IECON 2022–48th Annual Conference of the IEEE Industrial Electronics Society*, pp. 1–6, IEEE, 2022.
- [66] D. Christen, F. Jauch, and J. Biela, “Ultra-fast charging station for electric vehicles with integrated split grid storage,” in *2015 17th European Conference on Power Electronics and Applications (EPE'15 ECCE-Europe)*, pp. 1–11, IEEE, 2015.
- [67] M. Schweizer and J. W. Kolar, “Design and implementation of a highly efficient three-level t-type converter for low-voltage applications,” *IEEE Transactions on Power Electronics*, vol. 28, no. 2, pp. 899–907, 2012.
- [68] I. E. Commission, “Iec 61851-23: Electric vehicle conductive charging system - part 23: Dc electric vehicle charging station,” 2014.
- [69] N. Hassanzadeh, F. Yazdani, S. Haghbin, and T. Thiringer, “Design of a 50 kw phase-shifted full-bridge converter used for fast charging applications,” in *2017 IEEE Vehicle Power and Propulsion Conference (VPPC)*, pp. 1–5, IEEE, 2017.
- [70] S. Rivera, J. Rojas, S. Kouro, P. W. Lehn, R. Lizana, H. Renaudineau, and T. Dragičević, “Partial-power converter topology of type ii for efficient electric vehicle fast charging,” *IEEE Journal of Emerging and Selected Topics in Power Electronics*, vol. 10, no. 6, pp. 7839–7848, 2021.
- [71] J. Sabate, V. Vlatkovic, R. Ridley, F. Lee, and B. Cho, “Design considerations for high-voltage high-power full-bridge zero-voltage-switched pwm converter,” in *Fifth Annual Proceedings on Applied Power Electronics Conference and Exposition*, pp. 275–284, 1990.
- [72] F. Krismer and J. W. Kolar, “Accurate small-signal model for the digital control of an automotive bidirectional dual active bridge,” *IEEE transactions on power electronics*, vol. 24, no. 12, pp. 2756–2768, 2009.
- [73] B. Zhao, Q. Song, W. Liu, and Y. Sun, “Overview of dual-active-bridge isolated bidirectional dc–dc converter for high-frequency-link power-conversion system,” *IEEE Transactions on power electronics*, vol. 29, no. 8, pp. 4091–4106, 2013.
- [74] G. Arena, G. Aiello, G. Scelba, M. Cacciato, and F. Gennaro, “A cost-effective hardware in the loop implementation of dual active bridge for fast prototyping of electric vehicles charging controls,” in *2021 23rd European Conference on Power Electronics and Applications (EPE'21 ECCE Europe)*, pp. P–1, IEEE, 2021.
- [75] R. W. De Doncker, D. M. Divan, and M. H. Kheraluwala, “A three-phase soft-switched high-power-density dc/dc converter for high-power applications,” *IEEE transactions on industry applications*, vol. 27, no. 1, pp. 63–73, 1991.
- [76] N. H. Baars, J. Everts, H. Huisman, J. L. Duarte, and E. A. Lomonova, “A 80-kw isolated dc–dc converter for railway applications,” *IEEE Transactions on Power Electronics*, vol. 30, no. 12, pp. 6639–6647, 2015.
- [77] L. Costa, G. Buticchi, and M. Liserre, “Bidirectional series-resonant dc-dc converter with fault-tolerance capability for smart transformer,” in *2016 IEEE Energy Conversion Congress and Exposition (ECCE)*, pp. 1–7, IEEE, 2016.
- [78] L. Costa, G. Buticchi, and M. Liserre, “A fault-tolerant series-resonant dc–dc converter,” *IEEE transactions on power electronics*, vol. 32, no. 2, pp. 900–905, 2016.
- [79] N. Shafiei, M. Ordonez, M. Craciun, C. Botting, and M. Edington, “Burst mode elimination in high-power llc resonant battery charger for electric vehicles,” *IEEE Transactions on Power Electronics*, vol. 31, no. 2, pp. 1173–1188, 2015.
- [80] N. H. Kutkut, D. M. Divan, D. W. Novotny, and R. H. Marion, “Design considerations and topology selection for a 120-kw igbt converter for ev fast charging,” *IEEE Transactions on Power Electronics*, vol. 13, no. 1, pp. 169–178, 1998.
- [81] D. Cittanti, M. Gregorio, E. Armando, and R. Bojoi, “Digital multi-loop control of an llc resonant converter for electric vehicle dc fast charging,” in *2020 IEEE Energy Conversion Congress and Exposition (ECCE)*, pp. 4423–4430, IEEE, 2020.
- [82] G. Rizzoli, M. Mengoni, L. Vancini, G. Sala, A. Tani, and L. Zari, “Integrated boost-converter for 400 v-800 v fast-charging compatibility,” in *2022 Second International Conference on Sustainable Mobility Applications, Renewables and Technology (SMART)*, pp. 1–8, IEEE, 2022.
- [83] B. O. Aarninkhof, D. Lyu, T. B. Soeiro, and P. Bauer, “A reconfigurable two-stage 11kw dc-dc resonant converter for ev charging with a 150-1000v output voltage range,” *IEEE Transactions on Transportation Electrification*, 2023.
- [84] T. Kang, C. Kim, Y. Suh, H. Park, B. Kang, and D. Kim, “A design and control of bi-directional non-isolated dc-dc converter for rapid electric vehicle charging system,” in *2012 Twenty-Seventh Annual IEEE Applied Power Electronics Conference and Exposition (APEC)*, pp. 14–21, IEEE, 2012.
- [85] S. Liu, J. Liu, Y. Yang, and J. Zhong, “Design of intrinsically safe buck dc/dc converters,” in *2005 International Conference on Electrical Machines and Systems*, vol. 2, pp. 1327–1331, IEEE, 2005.
- [86] M. R. H. Bipu, D. Dadzie, S. Lukic, and I. Husain, “Open circuit switch fault management method of a multi-phase synchronous buck

- converter for ev charging application,” in *2023 IEEE Applied Power Electronics Conference and Exposition (APEC)*, pp. 2218–2222, IEEE, 2023.
- [87] W.-M. Eull, L. Zhou, W. Wang, G. Cen, and M. Preindl, “Non-isolated dc fast charger for electrified vehicles,” Aug. 26 2021. US Patent App. 17/173,524.
- [88] Y. Du, X. Zhou, S. Bai, S. Lukic, and A. Huang, “Review of non-isolated bi-directional dc-dc converters for plug-in hybrid electric vehicle charge station application at municipal parking decks,” in *2010 Twenty-Fifth Annual IEEE Applied Power Electronics Conference and Exposition (APEC)*, pp. 1145–1151, IEEE, 2010.
- [89] K. Nisha and D. N. Gaonkar, “Predictive control of three level bidirectional converter in bipolar dc microgrid for ev charging stations,” in *2020 IEEE International Conference on Power Electronics, Smart Grid and Renewable Energy (PESGRE2020)*, pp. 1–6, IEEE, 2020.
- [90] P. Putera, C. Klumpner, and P. Wheeler, “A bidirectional three-level interleaved dc-dc converter for an electric vehicle charging station operating in a wide range of battery currents and voltages,” in *11th International Conference on Power Electronics, Machines and Drives (PEMD 2022)*, vol. 2022, pp. 439–445, IET, 2022.
- [91] X. She, A. Q. Huang, and R. Burgos, “Review of solid-state transformer technologies and their application in power distribution systems,” *IEEE journal of emerging and selected topics in power electronics*, vol. 1, no. 3, pp. 186–198, 2013.
- [92] J. E. Huber and J. W. Kolar, “Volume/weight/cost comparison of a 1mva 10 kv/400 v solid-state against a conventional low-frequency distribution transformer,” in *2014 IEEE Energy Conversion Congress and Exposition (ECCE)*, pp. 4545–4552, IEEE, 2014.
- [93] L. Zheng, A. Marellapudi, V. R. Chowdhury, N. Bilakanti, R. P. Kandula, M. Saeeedifard, S. Grijalva, and D. Divan, “Solid-state transformer and hybrid transformer with integrated energy storage in active distribution grids: Technical and economic comparison, dispatch, and control,” *IEEE Journal of Emerging and Selected Topics in Power Electronics*, vol. 10, no. 4, pp. 3771–3787, 2022.
- [94] P. H. Kobos, T. E. Drennen, A. V. Outkin, E. K. Webb, S. M. Paap, and S. Wiryadinata, “Techno-economic analysis: Best practices and assessment tools,” tech. rep., Sandia National Lab.(SNL-CA), Livermore, CA (United States); Sandia National . . . , 2020.
- [95] J. E. Huber and J. W. Kolar, “Applicability of solid-state transformers in today’s and future distribution grids,” *IEEE Transactions on Smart Grid*, vol. 10, no. 1, pp. 317–326, 2017.
- [96] F. Wang, G. Wang, A. Huang, W. Yu, and X. Ni, “Design and operation of a 3.6 kv high performance solid state transformer based on 13kv sic mosfet and jbs diode,” in *2014 IEEE Energy Conversion Congress and Exposition (ECCE)*, pp. 4553–4560, IEEE, 2014.
- [97] D. Rothmund, T. Guillod, D. Bortis, and J. W. Kolar, “99% efficient 10 kv sic-based 7 kv/400 v dc transformer for future data centers,” *IEEE Journal of Emerging and Selected Topics in Power Electronics*, vol. 7, no. 2, pp. 753–767, 2018.
- [98] A. Maitra, S. Rajagopalan, J.-S. Lai, M. DuVall, and M. Mc-Granaghan, “Medium voltage stand alone dc fast charger,” May 30 2013. US Patent App. 13/479,389.
- [99] J.-S. Lai, W.-H. Lai, S.-R. Moon, L. Zhang, and A. Maitra, “A 15-kv class intelligent universal transformer for utility applications,” in *2016 IEEE Applied Power Electronics Conference and Exposition (APEC)*, pp. 1974–1981, IEEE, 2016.
- [100] S. Srdic, C. Zhang, X. Liang, W. Yu, and S. Lukic, “A sic-based power converter module for medium-voltage fast charger for plug-in electric vehicles,” in *2016 IEEE Applied Power Electronics Conference and Exposition (APEC)*, pp. 2714–2719, IEEE, 2016.
- [101] M. Vasiladiotis, B. Bahrani, N. Burger, and A. Rufer, “Modular converter architecture for medium voltage ultra fast ev charging stations: Dual half-bridge-based isolation stage,” in *2014 International Power Electronics Conference (IPEC-Hiroshima 2014-ECCE ASIA)*, pp. 1386–1393, IEEE, 2014.
- [102] L. Camurca, T. Pereira, F. Hoffmann, and M. Liserre, “Analysis, limitations, and opportunities of modular multilevel converter-based architectures in fast charging stations infrastructures,” *IEEE Transactions on Power Electronics*, vol. 37, no. 9, pp. 10747–10760, 2022.
- [103] S. Debnath, J. Qin, B. Bahrani, M. Saeeedifard, and P. Barbosa, “Operation, control, and applications of the modular multilevel converter: A review,” *IEEE transactions on power electronics*, vol. 30, no. 1, pp. 37–53, 2014.
- [104] L. Camurca, X. Gao, L. F. Costa, and M. Liserre, “Design of a medium voltage dc fast charging station with grid voltage regulation and central modular multilevel converter,” in *2018 IEEE Energy Conversion Congress and Exposition (ECCE)*, pp. 2798–2804, IEEE, 2018.
- [105] M. Mao, Y. Ding, L. Chang, N. D. Hatzigiorgiou, Q. Chen, T. Tao, and Y. Li, “Multi-objective power management for ev fleet with mmc-based integration into smart grid,” *IEEE Transactions on Smart Grid*, vol. 10, no. 2, pp. 1428–1439, 2017.
- [106] M. Hassanifar, V. Hrshikesan, J.-H. Jung, S. Bazyar, H. Beiranvand, T. Pereira, M. Langwasser, and M. Liserre, “Modular multilevel converters enabling multibus dc distribution,” in *2023 IEEE 17th International Conference on Compatibility, Power Electronics and Power Engineering (CPE-POWERENG)*, pp. 1–7, IEEE, 2023.
- [107] Y. Liang and C. Nwankpa, “A new type of statcom based on cascading voltage-source inverters with phase-shifted unipolar spwm,” *IEEE transactions on industry applications*, vol. 35, no. 5, pp. 1118–1123, 1999.
- [108] A. Marzoughi, R. Burgos, D. Boroyevich, and Y. Xue, “Design and comparison of cascaded h-bridge, modular multilevel converter, and 5-l active neutral point clamped topologies for motor drive applications,” *IEEE Transactions on Industry Applications*, vol. 54, no. 2, pp. 1404–1413, 2017.
- [109] J. Vivas, G. Bergna, and M. Boyra, “Comparison of multilevel converter-based statcoms,” in *Proceedings of the 2011 14th European Conference on Power Electronics and Applications*, pp. 1–10, IEEE, 2011.
- [110] N. Elsayad and O. A. Mohammed, “A cascaded high frequency ac link system for large-scale pv-assisted ev fast charging stations,” in *2017 IEEE Transportation Electrification Conference and Expo (ITEC)*, pp. 90–94, IEEE, 2017.
- [111] F. Hoffmann, J. Person, M. Andresen, M. Liserre, F. D. Freijedo, and T. Wijekoon, “A multiport partial power processing converter with energy storage integration for ev stationary charging,” *IEEE Journal of Emerging and Selected Topics in Power Electronics*, vol. 10, no. 6, pp. 7950–7962, 2021.
- [112] A. Stanojević, Y. E. Bouvier, and P. J. Grbović, “Comparison of 2-stage isolated converters for fast ev charger, using partial power,” in *IECON 2022 – 48th Annual Conference of the IEEE Industrial Electronics Society*, pp. 1–6, 2022.
- [113] N. G. F. dos Santos, J. R. R. Zientarski, and M. L. da Silva Martins, “A review of series-connected partial power converters for dc-dc applications,” *IEEE Journal of Emerging and Selected Topics in Power Electronics*, vol. 10, no. 6, pp. 7825–7838, 2021.
- [114] V. M. Iyer, S. Guler, G. Gohil, and S. Bhattacharya, “An approach towards extreme fast charging station power delivery for electric vehicles with partial power processing,” *IEEE Transactions on Industrial Electronics*, vol. 67, no. 10, pp. 8076–8087, 2019.
- [115] R. V. Muñoz, H. Renaudineau, S. Rivera, and S. Kouro, “Evaluation of dc-dc buck-boost partial power converters for ev fast charging application,” in *IECON 2021–47th Annual Conference of the IEEE Industrial Electronics Society*, pp. 1–6, IEEE, 2021.
- [116] M. C. Mira, Z. Zhang, K. L. Jørgensen, and M. A. E. Andersen, “Fractional charging converter with high efficiency and low cost for electrochemical energy storage devices,” *IEEE Transactions on Industry Applications*, vol. 55, no. 6, pp. 7461–7470, 2019.
- [117] N. Hassanpour, A. Chub, A. Blinov, and D. Vinnikov, “Soft-switching bidirectional step-up/down partial power converter with reduced components stress,” *IEEE Transactions on Power Electronics*, vol. 38, no. 11, pp. 14166–14177, 2023.
- [118] D. Pesantez, H. Renaudineau, S. Rivera, and S. Kouro, “Transformerless partial power converter for electric vehicle fast charging stations,” in *2022 IEEE Energy Conversion Congress and Exposition (ECCE)*, pp. 1–6, IEEE, 2022.
- [119] K. Drexler, J. Gehring, B. Wunder, Y. Zhou, M. März, and V. Lorentz, “Evaluation of semiconductor-based isolation for electric vehicle chargers in dc microgrids,” in *Proceedings of 6th IEEE International Conference on DC Microgrids (ICDCM 2024)*, pp. 1–6, 2024.
- [120] N. G. F. d. Santos, A. Toebe, P. H. B. Löbler, L. Schuch, M. L. d. S. Martins, and C. Rech, “A high-efficient single-switch switched-capacitor partial power converter for on-board chargers,” *IEEE Transactions on Power Electronics*, vol. early access, pp. 1–11, 2024.
- [121] F. Flores-Bahamonde, H. Renaudineau, A. M. Llor, A. Chub, and S. Kouro, “The dc transformer power electronic building block: Pow-

- ering next-generation converter design,” *IEEE Industrial Electronics Magazine*, vol. 17, no. 1, pp. 21–35, 2023.
- [122] B. Stevanović, D. Serrano, M. Vasić, P. Alou, J. A. Oliver, and J. A. Cobos, “Highly efficient, full zvs, hybrid, multilevel dc/dc topology for two-stage grid-connected 1500-v pv system with employed 900-v sic devices,” *IEEE Journal of Emerging and Selected Topics in Power Electronics*, vol. 7, no. 2, pp. 811–832, 2019.
- [123] E. Serban, C. Pondiche, and M. Ordóñez, “Analysis and design of bidirectional parallel-series dab-based converter,” *IEEE Transactions on Power Electronics*, 2023.
- [124] S. Chaurasiya and B. Singh, “A bidirectional fast ev charger for wide voltage range using three-level dab based on current and voltage stress optimization,” *IEEE Transactions on Transportation Electrification*, vol. 9, no. 1, pp. 1330–1340, 2022.
- [125] O. Zayed, A. Elezab, A. Abuelnaga, and M. Narimani, “A dual-active bridge converter with a wide output voltage range (200–1000 v) for ultra-fast dc-connected ev charging stations,” *IEEE Transactions on Transportation Electrification*, 2022.
- [126] A. Elezab, O. Zayed, A. Abuelnaga, and M. Narimani, “High efficiency llc resonant converter with wide output range of 200–1000 v for dc-connected evs ultra-fast charging stations,” *IEEE Access*, vol. 11, pp. 33037–33048, 2023.
- [127] S. B. Althurthi, K. Rajashekara, and T. Debnath, “A novel ultra-wide output range dc-dc converter for ev fast charging,” *IEEE Journal of Emerging and Selected Topics in Industrial Electronics*, 2024.
- [128] L. Zhao, Y. Pei, L. Wang, L. Pei, W. Cao, and Y. Gan, “Design methodology of bidirectional resonant clc charger for wide voltage range based on parameter equivalent and time domain model,” *IEEE Transactions on Power Electronics*, vol. 37, no. 10, pp. 12041–12064, 2022.
- [129] Y. Xuan, X. Yang, W. Chen, T. Liu, and X. Hao, “A novel three-level clc resonant dc-dc converter for bidirectional ev charger in dc microgrids,” *IEEE Transactions on Industrial Electronics*, vol. 68, no. 3, pp. 2334–2344, 2021.
- [130] V. Sidorov, A. Chub, D. Vinnikov, and F. Z. Peng, “Survey of topology morphing control techniques for performance enhancement of galvanically isolated dc-dc converters,” *IEEE Open Journal of the Industrial Electronics Society*, vol. 3, pp. 751–777, 2022.
- [131] Y. Zuo, X. Pan, and C. Wang, “A reconfigurable bidirectional isolated llc resonant converter for ultra-wide voltage-gain range applications,” *IEEE Transactions on Industrial Electronics*, vol. 69, no. 6, pp. 5713–5723, 2021.
- [132] M. Barresi, E. Ferri, and L. Piegari, “A fast charging station for electric vehicles with 400-v/800-v charging ports and second-life batteries,” in *2023 IEEE 17th International Conference on Compatibility, Power Electronics and Power Engineering (CPE-POWERENG)*, pp. 1–8, IEEE, 2023.
- [133] D. Lyu, T. B. Soeiro, and P. Bauer, “Multiobjective design and benchmark of wide voltage range phase shift full-bridge dc/dc converters for ev charging application,” *IEEE Transactions on Transportation Electrification*, vol. 10, no. 1, pp. 288–304, 2023.
- [134] D. Kumar, F. Zare, and A. Ghosh, “Dc microgrid technology: system architectures, ac grid interfaces, grounding schemes, power quality, communication networks, applications, and standardizations aspects,” *Ieee Access*, vol. 5, pp. 12230–12256, 2017.
- [135] F. Xu, A. Elasser, S. Colombi, and K. K. Huh, “Dc fast charging station for electric vehicles,” Dec. 5 2019. US Patent App. 16/475,464.
- [136] L. Qi, “Multiple vehicle charging system,” Jan. 25 2022. US Patent 11,230,202.
- [137] G. Sharma, V. K. Sood, M. S. Alam, and S. M. Shariff, “Comparison of common dc and ac bus architectures for ev fast charging stations and impact on power quality,” *eTransportation*, vol. 5, p. 100066, 2020.
- [138] “Report on webinar: “low voltage direct current (lvdc) and dc technologies: Potential applications for a clean energy transition,”” November 2021. Accessed 2023-03-29.
- [139] L. Tan, B. Wu, S. Rivera, and V. Yaramasu, “Comprehensive dc power balance management in high-power three-level dc-dc converter for electric vehicle fast charging,” *IEEE Transactions on Power Electronics*, vol. 31, no. 1, pp. 89–100, 2015.
- [140] Nxu. [Online]. Available: <https://nxuenergy.com/>.
- [141] A. Meintz, M. Starke, and T. Bohn, “Charging infrastructure technologies: Development of a multiport, 1 mw charging system for medium-and heavy-duty electric vehicles,” tech. rep., National Renewable Energy Lab.(NREL), Golden, CO (United States), 2022.
- [142] I. Mareev, J. Becker, and D. U. Sauer, “Battery dimensioning and life cycle costs analysis for a heavy-duty truck considering the requirements of long-haul transportation,” *Energies*, vol. 11, no. 1, p. 55, 2017.
- [143] J. Schneider, O. Teichert, M. Zähringer, G. Balke, and M. Lienkamp, “The novel megawatt charging system standard: Impact on battery size and cell requirements for battery-electric long-haul trucks,” *eTransportation*, vol. 17, p. 100253, 2023.
- [144] P. Mishra, E. Miller, S. Santhanagopalan, K. Bennion, and A. Meintz, “A framework to analyze the requirements of a multiport megawatt-level charging station for heavy-duty electric vehicles,” *Energies*, vol. 15, no. 10, p. 3788, 2022.
- [145] M. Zhang, X. Zhu, B. Mather, P. Kulkani, and A. Meintz, “Location selection of fast-charging station for heavy-duty evs using gis and grid analysis,” in *2021 IEEE Power & Energy Society Innovative Smart Grid Technologies Conference (ISGT)*, pp. 1–5, IEEE, 2021.
- [146] X. Zhu, P. Mishra, B. Mather, M. Zhang, and A. Meintz, “Grid impact analysis and mitigation of en-route charging stations for heavy-duty electric vehicles,” *IEEE Open Access Journal of Power and Energy*, vol. 10, pp. 141–150, 2023.
- [147] X. Zhu, R. Mahmud, B. Mather, P. Mishra, and A. Meintz, “Grid voltage control analysis for heavy-duty electric vehicle charging stations,” in *2021 IEEE Power & Energy Society Innovative Smart Grid Technologies Conference (ISGT)*, pp. 1–5, IEEE, 2021.
- [148] S. Wang, R. Crosier, and Y. Chu, “Investigating the power architectures and circuit topologies for megawatt superfast electric vehicle charging stations with enhanced grid support functionality,” in *2012 IEEE international electric vehicle conference*, pp. 1–8, IEEE, 2012.
- [149] M. Starke, R. S. K. Moorthy, A. Adib, B. Dean, M. Chinthavali, B. Xiao, and S. Campbell, “A mw scale charging architecture for supporting extreme fast charging of heavy-duty electric vehicles,” in *2022 IEEE Transportation Electrification Conference & Expo (ITEC)*, pp. 485–490, IEEE, 2022.
- [150] A. Burnham, E. J. Dufek, T. Stephens, J. Francfort, C. Michelbacher, R. B. Carlson, J. Zhang, R. Vijayagopal, F. Dias, M. Mohanpurkar, et al., “Enabling fast charging—infrastructure and economic considerations,” *Journal of Power Sources*, vol. 367, pp. 237–249, 2017.
- [151] R. Moorthy, M. Starke, B. Dean, A. Adib, S. Campbell, and M. Chinthavali, “Megawatt scale charging system architecture,” in *2022 IEEE Energy Conversion Congress and Exposition (ECCE)*, pp. 1–8, IEEE, 2022.
- [152] D. Kucevic, C. N. Truong, A. Jossen, and H. C. Hesse, “Lithium-ion battery storage design for buffering fast charging stations for battery electric vehicles and electric buses,” in *NEIS 2018: Conference on Sustainable Energy Supply and Energy Storage Systems*, pp. 1–6, VDE, 2018.
- [153] S. Funke, P. Jochem, S. Ried, and T. Gnann, “Fast charging stations with stationary batteries: A techno-economic comparison of fast charging along highways and in cities,” *Transportation Research Procedia*, vol. 48, pp. 3832–3849, 2020.
- [154] Y. Yang, S. Bremner, C. Menictas, and M. Kay, “Battery energy storage system size determination in renewable energy systems: A review,” *Renewable and Sustainable Energy Reviews*, vol. 91, pp. 109–125, 2018.
- [155] S. Bai and S. Lukic, “Design considerations for dc charging station for plug-in vehicles,” in *2011 IEEE Vehicle Power and Propulsion Conference*, pp. 1–6, IEEE, 2011.
- [156] R. Zhou, M. Kechmir, and P. Pant, “Direct current fast charging systems with grid tied energy storage systems,” Jan. 12 2023. US Patent App. 17/370,228.
- [157] C. Van De Water, “High power bidirectional grid connected charger with split battery architecture,” Nov. 15 2022. US Patent 11,498,448.
- [158] J. Engelhardt, J. M. Zepter, T. Gabderakhmanova, and M. Marinelli, “Energy management of a multi-battery system for renewable-based high power ev charging,” *eTransportation*, vol. 14, p. 100198, 2022.
- [159] K. van der Horst, I. Diab, G. R. Chandra Mouli, and P. Bauer, “Methods for increasing the potential of integration of ev chargers into the dc catenary of electric transport grids: A trolleygrid case study,” *eTransportation*, vol. 18, p. 100271, 2023.
- [160] I. Diab, G. R. C. Mouli, and P. Bauer, “Increasing the integration potential of ev chargers in dc trolleygrids: A bilateral substation-voltage tuning approach,” in *2022 International Symposium on Power*

- Electronics, Electrical Drives, Automation and Motion (SPEEDAM)*, pp. 264–269, 2022.
- [161] D. Dujic, F. Kieferndorf, F. Canales, and U. Drogenik, “Power electronic traction transformer technology,” in *Proceedings of The 7th International Power Electronics and Motion Control Conference*, vol. 1, pp. 636–642, 2012.
- [162] H. Hayashiya and K. Kondo, “Recent trends in power electronics applications as solutions in electric railways,” *IEEJ Transactions on Electrical and Electronic Engineering*, vol. 15, no. 5, pp. 632–645, 2020.
- [163] K. Smith, L. Hunter, S. Galloway, C. Booth, C. Kerr, and M. Kellett, “Integrated charging of evs using existing lvdc light rail infrastructure: A case study,” in *2019 IEEE Third International Conference on DC Microgrids (ICDCM)*, pp. 1–7, 2019.
- [164] M. Weisbach, T. Schneider, D. Maune, H. Fechtner, U. Spaeth, R. Wegener, S. Soter, and B. Schmuelling, “Intelligent multi-vehicle dc/dc charging station powered by a trolley bus catenary grid,” *Energies*, vol. 14, p. 8399, Dec 2021.
- [165] J. Pouget, B. Guo, L. Bossoney, J. Coppex, D. Roggo, and C. Ellert, “Energetic simulation of dc railway micro-grid interconnecting with pv solar panels, ev charger infrastructures and electrical railway network,” in *2020 IEEE Vehicle Power and Propulsion Conference (VPPC)*, pp. 1–7, 2020.
- [166] M. Bartłomiejczyk, L. Jarzbowicz, and R. Hrbáč, “Application of traction supply system for charging electric cars,” vol. 15, p. 1448, MDPI AG, 2022.
- [167] P. Cheng, H. Kong, J. Ma, and L. Jia, “Overview of resilient traction power supply systems in railways with interconnected microgrid,” *CSEE Journal of Power and Energy Systems*, vol. 7, no. 5, pp. 1122–1132, 2021.
- [168] S. D’Arco, L. Piegari, and P. Tricoli, “Comparative analysis of topologies to integrate photovoltaic sources in the feeder stations of ac railways,” *IEEE Transactions on Transportation Electrification*, vol. 4, no. 4, pp. 951–960, 2018.
- [169] L. Jiang, X. Diao, Y. Zhang, J. Zhang, and T. Li, “Review of the charging safety and charging safety protection of electric vehicles,” *World Electric Vehicle Journal*, vol. 12, no. 4, p. 184, 2021.
- [170] “RC59: Recommendations for fire safety when charging electric vehicles.” U.K. Fire Protection Assoc., Gloucestershire, U.K., Rep. no. RC59, 2023. [Online]. Available: <https://www.thefpa.co.uk/adv-ice-and-guidance/free-documents?=%20Medium-sized%20Businesses.%20MAINTENANCE%20CHECKLISTS%20-%20APPENDIX%20TEMPLATE%20FORMS,%20CONTROL%20OF%20DUST%20EXPLOSIONS&q=RC59%20FIRE%20SAFETY%20WHEN%20CHARGING%20ELECTRIC%20VEHICLES>.
- [171] B. Wang, P. Dehghanian, S. Wang, and M. Mitolo, “Electrical safety considerations in large-scale electric vehicle charging stations,” *IEEE Transactions on Industry Applications*, vol. 55, no. 6, pp. 6603–6612, 2019.
- [172] I. E. Commission, “Iec 61851-1: Electric vehicle conductive charging system - part 1: General requirements,” 2017.
- [173] I. E. Commission, “Iec 61140: Protection against electric shock - common aspects for installation and equipment,” 2016.
- [174] M. Valente, T. Wijekoon, F. Freijedo, P. Pescetto, G. Pellegrino, and R. Bojoi, “Integrated on-board ev battery chargers: New perspectives and challenges for safety improvement,” in *2021 IEEE Workshop on Electrical Machines Design, Control and Diagnosis (WEMDCD)*, pp. 349–356, IEEE, 2021.
- [175] D. J. Perreault, J. Hu, J. M. Rivas, Y. Han, O. Leitermann, R. C. Pilawa-Podgurski, A. Sagneri, and C. R. Sullivan, “Opportunities and challenges in very high frequency power conversion,” in *2009 Twenty-Fourth Annual IEEE Applied Power Electronics Conference and Exposition*, pp. 1–14, IEEE, 2009.
- [176] J. Wang, Y. Zhang, M. Elshaer, W. Perdikakis, C. Yao, K. Zou, Z. Xu, and C. Chen, “Nonisolated electric vehicle chargers: Their current status and future challenges,” *IEEE Electrification Magazine*, vol. 9, no. 2, pp. 23–33, 2021.
- [177] Y. Huo, F. Bouffard, and G. Joós, “An energy management approach for electric vehicle fast charging station,” in *2017 IEEE Electrical Power and Energy Conference (EPEC)*, pp. 1–6, IEEE, 2017.
- [178] S. S. Varghese, G. Joos, and S. Q. Ali, “Load management strategy for dc fast charging stations,” in *2021 IEEE Energy Conversion Congress and Exposition (ECCE)*, pp. 1620–1626, IEEE, 2021.
- [179] C. Leone, M. Longo, L. M. Fernández-Ramírez, and P. García-Triviño, “Multi-objective optimization of ultra-fast charging stations with pv and energy storage systems,” *IEEE Access*, pp. 1–1, 2022.
- [180] Y. Yan, J. Jiang, W. Zhang, M. Huang, Q. Chen, and H. Wang, “Research on power demand suppression based on charging optimization and bess configuration for fast-charging stations in beijing,” *Applied Sciences*, vol. 8, no. 8, p. 1212, 2018.
- [181] R. Khezri, P. Razmi, A. Mahmoudi, A. Bidram, and M. H. Khooban, “Machine learning-based sizing of a renewable-battery system for grid-connected homes with fast-charging electric vehicle,” *IEEE Transactions on Sustainable Energy*, vol. 14, no. 2, pp. 837–848, 2022.
- [182] F. Marasciuolo, M. Dicorato, G. Tricarico, P. Montegiglio, G. Forte, and M. Trovato, “The influence of ev usage scenarios on dc microgrid techno-economic operation,” *IEEE Transactions on Industry Applications*, vol. 58, no. 3, pp. 3957–3966, 2022.
- [183] F. Marasciuolo, C. Orozco, M. Dicorato, A. Borghetti, and G. Forte, “Chance-constrained calculation of the reserve service provided by ev charging station clusters in energy communities,” *IEEE Transactions on Industry Applications*, 2023.
- [184] A. A. Mohamed, M. Jun, R. Mahmud, P. Mishra, S. N. Patel, I. Tolbert, S. Santhanagopalan, and A. Meintz, “Hierarchical control of megawatt-scale charging stations for electric trucks with distributed energy resources,” *IEEE Transactions on Transportation Electrification*, 2022.
- [185] A. Zahedmanesh, K. M. Muttaqi, and D. Sutanto, “Active and reactive power control of pev fast charging stations using a consecutive horizon-based energy management process,” *IEEE Transactions on Industrial Informatics*, vol. 17, no. 10, pp. 6742–6753, 2020.
- [186] H. Khalkhali and S. H. Hosseini, “Multi-stage stochastic framework for simultaneous energy management of slow and fast charge electric vehicles in a restructured smart parking lot,” *International Journal of Electrical Power & Energy Systems*, vol. 116, p. 105540, 2020.
- [187] W. ur Rehman, J. W. Kimball, and R. Bo, “Multi-layered energy management framework for extreme fast charging stations considering demand charges, battery degradation, and forecast uncertainties,” *IEEE Transactions on Transportation Electrification*, 2023.
- [188] M. M. Mahfouz and R. Iravani, “A supervisory control for resilient operation of the battery-enabled dc fast charging station and the grid,” *IEEE Transactions on Power Delivery*, vol. 36, no. 4, pp. 2532–2541, 2020.
- [189] O. Elma, “A dynamic charging strategy with hybrid fast charging station for electric vehicles,” *Energy*, vol. 202, p. 117680, 2020.
- [190] V. T. Tran, M. R. Islam, K. M. Muttaqi, and D. Sutanto, “An efficient energy management approach for a solar-powered ev battery charging facility to support distribution grids,” *IEEE Transactions on Industry Applications*, vol. 55, no. 6, pp. 6517–6526, 2019.
- [191] D. Kler, A. Z. Hosseini, S. Varghese, C. Sun, and G. Joos, “A rule based ems for fast charging station with chil implementation,” in *2020 IEEE Energy Conversion Congress and Exposition (ECCE)*, pp. 1319–1324, IEEE, 2020.
- [192] A. Al Wahedi and Y. Bicer, “A case study in qatar for optimal energy management of an autonomous electric vehicle fast charging station with multiple renewable energy and storage systems,” *Energies*, vol. 13, no. 19, p. 5095, 2020.
- [193] F. M. Shakeel and O. P. Malik, “Fuzzy based energy management system for a micro-grid with a v2g parking lot,” in *2020 IEEE Electric Power and Energy Conference (EPEC)*, pp. 1–5, IEEE, 2020.
- [194] S. F. Tie and C. W. Tan, “A review of energy sources and energy management system in electric vehicles,” *Renewable and sustainable energy reviews*, vol. 20, pp. 82–102, 2013.
- [195] F. R. Salmasi, “Control strategies for hybrid electric vehicles: Evolution, classification, comparison, and future trends,” *IEEE Transactions on vehicular technology*, vol. 56, no. 5, pp. 2393–2404, 2007.
- [196] E. Taherzadeh, H. Radmanesh, and A. Mehrizi-Sani, “A comprehensive study of the parameters impacting the fuel economy of plug-in hybrid electric vehicles,” *IEEE Transactions on Intelligent Vehicles*, vol. 5, no. 4, pp. 596–615, 2020.
- [197] H. Nossair and F. Bouffard, “Flexibility envelopes for power system operational planning,” *IEEE Transactions on Sustainable Energy*, vol. 6, no. 3, pp. 800–809, 2015.

- [198] H. Nosair and F. Bouffard, "Energy-centric flexibility management in power systems," *IEEE Transactions on Power Systems*, vol. 31, no. 6, pp. 5071–5081, 2016.
- [199] M. Dicatoro, G. Tricarico, F. Marasciuolo, G. Forte, and M. Trovato, "Performance analysis of ev stations optimal operation in dc microgrid configurations," in *2020 IEEE International Conference on Environment and Electrical Engineering and 2020 IEEE Industrial and Commercial Power Systems Europe (EEEIC/I&CPS Europe)*, pp. 1–6, IEEE, 2020.
- [200] F. Marasciuolo, C. Orozco, M. Dicatoro, A. Borghetti, and G. Forte, "Two-stage scheduling of electrical vehicle charging station clusters in a community of dc microgrids," in *2021 IEEE International Conference on Environment and Electrical Engineering and 2021 IEEE Industrial and Commercial Power Systems Europe (EEEIC/I&CPS Europe)*, pp. 1–6, IEEE, 2021.
- [201] A. Bakeer, A. Chub, Y. Shen, and A. Sangwongwanich, "Reliability analysis of battery energy storage system for various stationary applications," *Journal of Energy Storage*, vol. 50, p. 104217, 2022.
- [202] C. Alcaraz, J. Lopez, and S. Wolthusen, "Ocpp protocol: Security threats and challenges," *IEEE Transactions on Smart Grid*, vol. 8, no. 5, pp. 2452–2459, 2017.
- [203] Z. Garofalaki, D. Kosmanos, S. Moschoyiannis, D. Kallergis, and C. Douligeris, "Electric vehicle charging: A survey on the security issues and challenges of the open charge point protocol (ocpp)," *IEEE Communications Surveys & Tutorials*, 2022.
- [204] J. Johnson, T. Berg, B. Anderson, and B. Wright, "Review of electric vehicle charger cybersecurity vulnerabilities, potential impacts, and defenses," *Energies*, vol. 15, no. 11, p. 3931, 2022.
- [205] "Open charge point protocol 1.6." Open Charge Alliance. 2015. [Online]. Available: <https://www.openchargealliance.org/protocols/ocpp-16/>.
- [206] "Open charge point protocol 2.0.1." Open Charge Alliance. 2018. [Online]. Available: <https://www.openchargealliance.org/protocols/ocpp-201/>.
- [207] K. Bao, H. Valev, M. Wagner, and H. Schmeck, "A threat analysis of the vehicle-to-grid charging protocol iso 15118," *Computer Science-Research and Development*, vol. 33, no. 1-2, pp. 3–12, 2018.
- [208] R. Falk and S. Fries, "Electric vehicle charging infrastructure security considerations and approaches," *Proc. of INTERNET*, pp. 58–64, 2012.
- [209] M. A. Mustafa, N. Zhang, G. Kalogridis, and Z. Fan, "Smart electric vehicle charging: Security analysis," in *2013 IEEE PES Innovative Smart Grid Technologies Conference (ISGT)*, pp. 1–6, IEEE, 2013.
- [210] Z. El-Rewini, K. Sadatsharan, D. F. Selvaraj, S. J. Plathottam, and P. Ranganathan, "Cybersecurity challenges in vehicular communications," *Vehicular Communications*, vol. 23, p. 100214, 2020.
- [211] D. Reeh, F. C. Tapia, Y.-W. Chung, B. Khaki, C. Chu, and R. Gadh, "Vulnerability analysis and risk assessment of ev charging system under cyber-physical threats," in *2019 IEEE Transportation Electrification Conference and Expo (ITEC)*, pp. 1–6, IEEE, 2019.
- [212] J. Antoun, M. E. Kabir, B. Moussa, R. Atallah, and C. Assi, "A detailed security assessment of the ev charging ecosystem," *IEEE Network*, vol. 34, no. 3, pp. 200–207, 2020.
- [213] S. Lightman, S. Lightman, and T. Brewer, *Symposium on federally funded research on cybersecurity of electric vehicle supply equipment (EVSE)*. US Department of Commerce, National Institute of Standards and Technology, 2020.
- [214] R. P. Parameswarath, N. V. Abhishek, and B. Sikdar, "Prevent: A mechanism for preventing message tampering attacks in electric vehicle networks," in *2023 IEEE 97th Vehicular Technology Conference (VTC2023-Spring)*, pp. 1–5, IEEE, 2023.
- [215] J. Chen, Y. Tang, Y. Zhou, G. Liu, J. Luan, and Y. Li, "Inference of tampering based on measurement discrepancy in ev charging station," in *2023 IEEE 6th International Electrical and Energy Conference (CIEEC)*, pp. 3398–3403, IEEE, 2023.
- [216] N. Bhusal, M. Gautam, and M. Benidris, "Cybersecurity of electric vehicle smart charging management systems," in *2020 52nd North American Power Symposium (NAPS)*, pp. 1–6, IEEE, 2021.
- [217] J. E. Rubio, C. Alcaraz, and J. Lopez, "Addressing security in ocpp: Protection against man-in-the-middle attacks," in *2018 9th IFIP International Conference on New Technologies, Mobility and Security (NTMS)*, pp. 1–5, IEEE, 2018.
- [218] R. Baker and I. Martinovic, "Losing the car keys: Wireless {PHY-Layer} insecurity in {EV} charging," in *28th USENIX Security Symposium (USENIX Security 19)*, pp. 407–424, 2019.
- [219] K. Gandhi and W. G. Morsi, "Impact of the open charge point protocol between the electric vehicle and the fast charging station on the cybersecurity of the smart grid," in *2022 IEEE Canadian Conference on Electrical and Computer Engineering (CCECE)*, pp. 235–240, IEEE, 2022.
- [220] F. Dehrouyeh, L. Yang, F. B. Ajaei, and A. Shami, "On tinyml and cybersecurity: Electric vehicle charging infrastructure use case," *arXiv preprint arXiv:2404.16894*, 2024.
- [221] I. Sharafaldin, A. H. Lashkari, A. A. Ghorbani, *et al.*, "Toward generating a new intrusion detection dataset and intrusion traffic characterization," *ICISSp*, vol. 1, pp. 108–116, 2018.
- [222] "(2017). cicids2017 dataset." [Online]. Available: <https://www.unb.ca/cic/datasets/ids-2017.html>.
- [223] S. Acharya, R. Mieth, R. Karri, and Y. Dvorkin, "False data injection attacks on data markets for electric vehicle charging stations," *Advances in Applied Energy*, vol. 7, p. 100098, 2022.
- [224] N. Piperigkos and A. S. Lalos, "Impact of false data injection attacks on decentralized electric vehicle charging protocols," *Transportation Research Procedia*, vol. 52, pp. 331–338, 2021.
- [225] F. Jiang, B. Liu, H. Li, H. Liao, H. Zhang, X. Lu, J. Peng, and Z. Huang, "A false data injection attack detection method for cooperative charging systems," *IEEE Transactions on Industry Applications*, vol. 58, no. 3, pp. 3946–3956, 2022.
- [226] G. Liang, S. R. Weller, J. Zhao, F. Luo, and Z. Y. Dong, "The 2015 ukraine blackout: Implications for false data injection attacks," *IEEE transactions on power systems*, vol. 32, no. 4, pp. 3317–3318, 2016.
- [227] S. Acharya, Y. Dvorkin, and R. Karri, "Public plug-in electric vehicles+ grid data: Is a new cyberattack vector viable?," *IEEE Transactions on Smart Grid*, vol. 11, no. 6, pp. 5099–5113, 2020.
- [228] A. Farraj, E. Hammad, A. Al Daoud, and D. Kundur, "A game-theoretic analysis of cyber switching attacks and mitigation in smart grid systems," *IEEE Transactions on Smart Grid*, vol. 7, no. 4, pp. 1846–1855, 2015.
- [229] S. Liu, D. Kundur, T. Zourntos, and K. Butler-Purry, "Coordinated variable structure switching in smart power systems: Attacks and mitigation," in *Proceedings of the 1st international conference on High Confidence Networked Systems*, pp. 21–30, 2012.
- [230] M. E. Kabir, M. Ghafouri, B. Moussa, and C. Assi, "A two-stage protection method for detection and mitigation of coordinated evse switching attacks," *IEEE Transactions on Smart Grid*, vol. 12, no. 5, pp. 4377–4388, 2021.
- [231] M. A. Sayed, R. Atallah, C. Assi, and M. Debbabi, "Electric vehicle attack impact on power grid operation," *International Journal of Electrical Power & Energy Systems*, vol. 137, p. 107784, 2022.
- [232] M. Basnet and M. H. Ali, "Exploring cybersecurity issues in 5g enabled electric vehicle charging station with deep learning," *IET Generation, Transmission & Distribution*, vol. 15, no. 24, pp. 3435–3449, 2021.
- [233] Y. Park, O. C. Onar, and B. Ozpineci, "Potential cybersecurity issues of fast charging stations with quantitative severity analysis," in *2019 IEEE CyberPELS (CyberPELS)*, pp. 1–7, IEEE, 2019.
- [234] E. Gumrukcu, A. Arsalan, G. Muriithi, C. Joglekar, A. Aboulebdah, M. A. Zehir, B. Papari, and A. Monti, "Impact of cyber-attacks on ev charging coordination: The case of single point of failure," in *2022 4th Global Power, Energy and Communication Conference (GPECOM)*, pp. 506–511, IEEE, 2022.
- [235] M. Girdhar, J. Hong, H. Lee, and T.-J. Song, "Hidden markov models-based anomaly correlations for the cyber-physical security of ev charging stations," *IEEE Transactions on Smart Grid*, vol. 13, no. 5, pp. 3903–3914, 2021.
- [236] Z. Zhou, B. Wang, M. Dong, and K. Ota, "Secure and efficient vehicle-to-grid energy trading in cyber physical systems: Integration of blockchain and edge computing," *IEEE Transactions on Systems, Man, and Cybernetics: Systems*, vol. 50, no. 1, pp. 43–57, 2019.
- [237] J. Kang, R. Yu, X. Huang, S. Maharjan, Y. Zhang, and E. Hossain, "Enabling localized peer-to-peer electricity trading among plug-in hybrid electric vehicles using consortium blockchains," *IEEE transactions on industrial informatics*, vol. 13, no. 6, pp. 3154–3164, 2017.
- [238] S. Aggarwal and N. Kumar, "A consortium blockchain-based energy trading for demand response management in vehicle-to-grid," *IEEE*

Transactions on Vehicular Technology, vol. 70, no. 9, pp. 9480–9494, 2021.

- [239] A. Reyna, C. Martín, J. Chen, E. Soler, and M. Díaz, "On blockchain and its integration with iot. challenges and opportunities," *Future generation computer systems*, vol. 88, pp. 173–190, 2018.
- [240] S. Beheshtaein, R. M. Cuzner, M. Forouzesh, M. Savaghebi, and J. M. Guerrero, "Dc microgrid protection: A comprehensive review," *IEEE Journal of Emerging and Selected Topics in Power Electronics*, 2019.
- [241] D. Coats, H. Suryanarayana, Z. Wang, A. Brissette, Y. Zhang, V. Ramanan, D. Scofield, D. Woodbury, N. Haltmeyer, and A. Benzinger, "Cybersecurity for grid connected extreme fast charging (xhc) station (cyberx)(final scientific/technical report)," tech. rep., ABB Inc., Zurich (Switzerland), 2021.
- [242] A. Sanghvi and T. Markel, "Cybersecurity for electric vehicle fast-charging infrastructure," in *2021 IEEE Transportation Electrification Conference & Expo (ITEC)*, pp. 573–576, IEEE, 2021.
- [243] D. Vinnikov, A. Chub, R. Kosenko, V. Sidorov, and A. Lindvest, "Implementation of global maximum power point tracking in photovoltaic microconverters: A survey of challenges and opportunities," *IEEE Journal of Emerging and Selected Topics in Power Electronics*, vol. 11, no. 2, pp. 2259–2280, 2021.



Gabriele Arena received his B.Sc. in Computer Engineering and M.Sc. degree in Automation Engineering and Control of Complex Systems from University of Catania, respectively in 2018 and 2020. He is currently an early stage researcher at the Karlsruhe Institute of Technology in Germany. He is also part of the project SMARTGYSUM "Research and Training Network for Smart and Green Energy Systems and Business Models" under a Marie Skłodowska-Curie Grant Agreement. His research interests include DC fast charging

technologies, isolated DC-DC converters for electric vehicle charging, and energy management of DC fast charging stations.



Andrii Chub (Senior Member, IEEE) received the B.Sc. and M.Sc. degrees in electronic systems from Chernihiv State Technological University, Ukraine, in 2008 and 2009, respectively, and the Ph.D. degree in electrical engineering from the Tallinn University of Technology, Tallinn, Estonia, in 2016. He was a Visiting Research Fellow at Kiel University in 2017 and a Postdoctoral Researcher at Federico Santa Maria Technical University from 2018 to 2019. He is currently a Senior Researcher with the Power Electronics Group, Department

of Electrical Power Engineering and Mechatronics, Tallinn University of Technology. He has co-authored over 200 articles and several book chapters on power electronics and applications and holds several patents and utility models. His research interests include advanced dc-dc converter topologies, renewable energy conversion systems, energy-efficient buildings, reliability, and fault-tolerance of power electronic converters. He is the Chair of the Joint IES/PELS/IAS/PES Chapter and the Secretary of the IEEE Estonia Section and an Associate Editor of the IEEE Journal of Emerging and Selected Topics in Industrial Electronics.



Mykola Lukianov received his B.Sc. and M.Sc. degrees in Electronics from the National Technical University of Ukraine "Igor Sikorsky Kyiv Polytechnic Institute" in 2018 and 2020 respectively. He is currently a PhD student at Gdansk University of Technology, Poland and a member of the research group involved in the SMARTGYSUM project "Research and Training Network for Smart and Green Energy Systems and Business Models". His research interests include PV converters, bidirectional EV chargers and their control algorithms.



Ryszard Strzelecki (Senior Member, IEEE) received the Graduate degree in industrial electronics from the Kyiv University of Technology, Kiev, Ukraine, in 1981, and the Ph.D. degree, in 1984, and a Habilitation (D.Sc.) degree in the theme "Prediction control of the forced commutation power electronics converters" from the Institute of Electrodynamics, Academy of Sciences of the UkrSSR, Kiev, Ukraine, in 1991. In 1999, he received the title of professor of technical sciences from the President of Poland. He is currently a Full

Professor with the Gdansk University of Technology and Gdynia Maritime University, and a Scientific Consultant of the AREX Ltd (WB Group), Gdynia, Poland. As of 2019, an elected member of the Committee on Electrical Engineering Polish Academy of Sciences. He is the author of scientific papers, monographs and patents. His research interests include topologies, control methods and unconventional applications of power electronic systems.



Dmitri Vinnikov (Fellow, IEEE) earned his Dipl.Eng., M.Sc., and Dr.Sc.techn. degrees in electrical engineering from Tallinn University of Technology, Tallinn, Estonia, in 1999, 2001, and 2005, respectively. He is currently the Head of the Power Electronics Group, Department of Electrical Power Engineering and Mechatronics, Tallinn University of Technology, Estonia. Since 2021 he has been a member of the Estonian Academy of Sciences. He was one of the founders of ZEBE—Estonian Centre of Excellence for zero energy and resource

efficient smart buildings and districts. He has authored or coauthored three books, five monographs and several book chapter as well as more than 400 published papers on power converter design and development, and is the holder of numerous patents and utility models in this field. His research interests include applied design of power electronic systems, implementation of wide bandgap power semiconductor, renewable energy conversion systems, energy-efficient buildings, reliability and fault-tolerance of power electronic converters. He is an associate editor of several IEEE journals (IEEE Transactions on Industrial Informatics, IEEE Open Journal of the Industrial Electronics Society, and IEEE Transactions on Power Electronics). He is the Chair of the IEEE Estonia Section.



Giovanni De Carne (S'14, M'17, SM'21) received the B.Sc. and M.Sc. degrees in electrical Engineering from the Polytechnic University of Bari, Italy, in 2011 and 2013, respectively, and the Ph.D. degree from the Chair of Power Electronics, Kiel University, Germany, in 2018. Prof. De Carne is currently W3 (full) professor at the Institute for Technical Physics at the Karlsruhe Institute of Technology, Karlsruhe, Germany, where he leads the "Real Time Systems for Energy Technologies" Group and the "Power Hardware In the Loop Lab".

He is currently supervising PhD students, managing academic and industrial projects, and developing multi-MW Power Hardware In the Loop testing

infrastructures for energy storage Systems and hydrogen-based drives. He has authored/coauthored more than 100 peer-reviewed scientific papers. His research interests include power electronics integration in power systems, solid state transformers, real time modelling, and power hardware in the loop. Prof. De Carne successfully hosted the IEEE eGrid2023 Workshop in Karlsruhe in October 2023 with high participation from industry. He has been technical program committee chair for several IEEE conferences, associate editor of the IEEE Open Journal of Power Electronics and several other IEEE and IET journals.