

HOW INTERACTION OF INTERNAL FORCES AND MOMENTS INFLUENCE THE LOAD-BEARING CAPACITY OF DOWELS

Elisabet Kuck¹, Carmen Sandhaas², Hans Joachim Blaß³

ABSTRACT: In connections with laterally loaded dowel-type fasteners, high density of the timber members leads to increased load-bearing capacities and influences the load-bearing behaviour. Material properties and system parameters like embedment strength and withdrawal capacity affect the connection performance and possible failure modes. In hardwood connections, failure mechanisms may include fastener failure due to higher stresses acting on fasteners during lateral loading. Multi-axial stress occurs as fasteners are subjected to bending moments, shear forces and normal forces, which vary with fastener type and geometry, potentially leading to shear or tensile failure of the fastener itself. The executed test programme aims at investigating fastener failure in connections with laterally loaded dowels. The interaction of bending moment and shear force occurring in the fastener has minor impact on the load-bearing capacity of connections. However, within inclined fastener sections, normal forces are present and lead to a reduced load-bearing capacity.

KEYWORDS: hardwood, connection, fastener failure, dowel

1 – INTRODUCTION

High density correlates with high material properties. This fundamental knowledge impacts many aspects of timber engineering and design. Engineered wood products like beech laminated veneer lumber (beech LVL) present new possibilities and competition for other building materials. This generated much interest in their use. However, using these relatively new materials often lacks experience and needs to be investigated further. For connections with laterally loaded dowel-type fasteners, higher density increases load-bearing capacities and influences the load-bearing behaviour. Material properties and system parameters like embedment strength, withdrawal and head pull-through capacities affect connection behaviour and failure modes. In hardwood connections, failure mechanisms include more than just embedment failure and plastic hinge formation. Current design considers the fastener's yield moment M_y and axial resistances (withdrawal, head pull-through, tension). Laterally loaded fasteners experience multi-axial stress, combining bending moments M , shear force V and normal force N , which vary by fastener type in dependence of their resistance in axial direction. In particular, threaded fasteners like screws generate higher normal forces than smooth dowels. Normal forces increase with load, relative displacement and fastener inclination, potentially leading to a fastener failure [1 - 5]. Different combinations of internal forces and moments are possible along the fastener axis. As presented by Blaß et al. [3] and Meyer [5], the load-bearing capacity can be reduced by a combination of internal forces and moments in the fastener. In general, brittle failure of the fastener cross-section represents a major uncertainty with regard to the reliable design of structures and connections. A

connection should not fail at loads lower than those calculated in accordance with the current design codes. The phenomenon is therefore of fundamental importance. In times of increased use of hardwood products, a basic knowledge of fastener failure is essential. Hence, two types of interaction, MV and MNV , are specifically analysed in tests and the configurations are designed accordingly.

2 – BACKGROUND

2.1. FORMER INTERACTION TESTS AND FINDINGS

Interaction of internal forces and moments is a phenomenon well known and investigated in steel design. First findings on cantilevers and beams exposed to pure bending or bending and axial loading were made until the middle of the 20th century. Roderick [6], for example, dealt with problems of highly redundant steel structures, which do not fail immediately at the yield point but redistribute bending moments, allowing less stressed areas to absorb energy. This requires considering the plastic properties of the material and knowledge about the transition between elastic and plastic material behaviour, which is part of the simple plastic theory. The simple plastic theory, commonly applied to mild steels, suggests that once yielding happens in tension or compression, the strain can continue indefinitely while the stress remains constant. The interaction of shear force and bending moments was rather neglected until then since, at that time, it was assumed that the magnitude of typical shear forces occurring in structural members are too low to impact the collapse load of a structure. However, these beginnings of the simple plasticity theory generally produced minor errors for transverse loading. It was assumed that additional shear forces led to an earlier onset

¹ Elisabet Kuck, Karlsruhe Institute of Technology, Reinhard-Baumeister-Platz 1, 76131 Karlsruhe, Germany, elisabet.kuck@kit.edu

² Carmen Sandhaas, Karlsruhe Institute of Technology, Karlsruhe, Germany, sandhaas@kit.edu

³ Hans Joachim Blaß, Karlsruhe Institute of Technology, Karlsruhe, Germany, blass@kit.edu

of yielding compared to pure bending loading, whilst the ultimate load remained the same [6]. According to Horne [7], the simple plastic theory, as described above, provides accurate stress distributions, with the exception of regions exhibiting full plastic behaviour in beams subjected to combined bending moments and shear forces. The influence of shear forces on the full plastic moment is, in general, negligible, with the exception of beams of a very short length. A reduction in the capacity of a cantilever due to shear stress is given in [7] for exemplary cross-sections, namely rectangular or I-beams, depending on the length-to-depth ratio ld . For example, a strongly increasing reduction has been observed starting from an ld ratio of a rectangular cross-section of about 3 and smaller. For very low length-to-depth ratios, the results are not valid as the entire cross-section experiences plastic deformation, and there is no separation of the plastic regions due to bending and shear stresses. It is noteworthy that the reduction in load-bearing capacity is typically higher for I-beams compared to rectangular beams. Initial approaches by Drucker [8] dealt with ideal-plastic materials and the definition of stress states when reaching failure loads. This resulted in the formulation of the „lower-bound theorem“ according to Drucker [9]. This theorem deals with stress states that fulfil the equilibrium conditions but do not violate the yield condition. Such equilibrium states correspond to loads that can be regarded as safe or correspond to loads not exceeding the ultimate load.

The above investigations eventually led to the formulation of interaction equations which are now commonly used in the design of steel cross-sections. Applying these earlier findings on steel components to fasteners in timber construction could provide additional knowledge on the failure loads and possible load-bearing capacities of connections with dowel-type fasteners. A possible interaction criterion acc. to [10] is:

$$\frac{M}{M_y} + \left(\frac{V}{F_{\text{shear}}} + \frac{N}{F_{\text{tens}}} \right)^2 \leq 1.0 \quad (1)$$

By applying the criterion to circular fasteners, resistances as yield moment M_y , shear capacity F_{shear} and tensile capacity F_{tens} of the fasteners are used.

2.2 TRANSFER TO DOWEL-TYPE FASTENERS

Basic assumptions for internal forces in dowel-type fasteners, i.e. distribution of shear force and bending moment along the fastener, are described by Johansen [11] and Meyer [12] in the middle of the 20th century. However, these models are only used to define the positions of plastic hinges and to identify the regions along the fastener where the embedment strength is reached. The question of the magnitude of interacting internal forces and moments within fasteners as well as their influence on the load-bearing capacity of connections is not addressed. However, using hardwoods is gaining momentum. Higher density leads to higher timber strengths and consequently causes higher stresses in fasteners. Exposing fasteners to higher stress in hardwood connections, can lead to this interaction being decisive in terms of the load-bearing capacity. Indeed, fastener failures are observed, see [1-5]. Hence, detailed information about occurring interactions of internal forces

and moments is necessary. This paper deals with specific tests investigating these interactions. Connection tests designed to enforce a fastener failure are carried out. These tests include two different interactions. On the one hand an MV interaction caused by bending moments and shear forces is investigated. On the other hand, failure mechanisms that cause an MNV interaction in the dowel-type fastener, i.e. failure mechanisms with inclined fasteners, are also investigated later on.

3 – EXPERIMENTAL PROGRAMME

Tailor-made tests investigating the effect of an interaction of internal forces and moments on the load-bearing capacity of connections with laterally loaded fasteners are carried out. By varying two high density timber products, the fastener material as well as the timber thickness, a cross-sectional failure of the dowels is specifically enforced and analysed. The main test programme includes double-shear steel-to-timber connections with thick outer steel plates as shown in Fig. 1. The thickness of the timber varies between 20 – 60 mm. Spacers that generate a gap of 0.5 mm in the shear planes are used to avoid friction between timber and the outer steel plates.

3.1 MATERIAL

Copper, aluminium, C15 steel and silversteel dowels with a nominal diameter of $d = 6$ mm are used. The middle timber of the connections is made of beech LVL or densified veneer wood (DVW) with different timber thicknesses to achieve the intended failure modes as explained in the next section.

3.2 FAILURE MODES

For the failure modes studied, Fig. 2 provides assumptions and force diagrams with corresponding forces and moments acting in the shear plane.

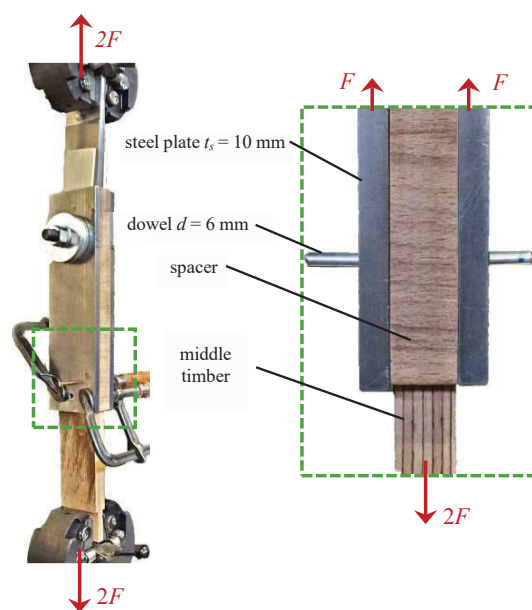

Figure 1: Test setup for connection tests.

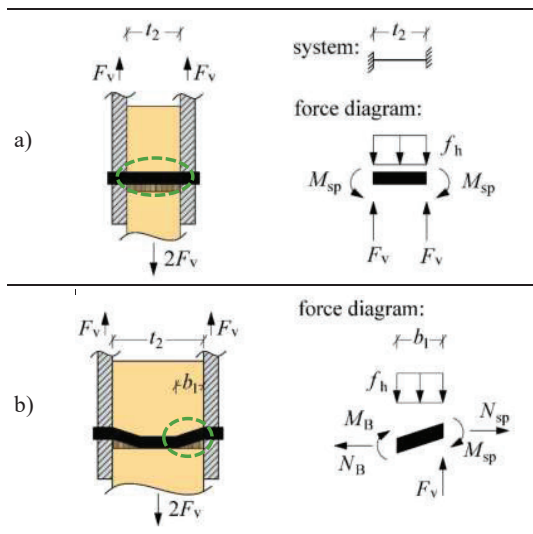

Figure 2: Force diagrams for two possible failure modes:

- a) Straight fastener axis
- b) Inclined fastener axis

The different possible connection failure modes are:

- a) Straight fastener: timber failure due to embedment or splitting or a fastener shear failure
- b) Inclined fastener: formation of two plastic hinges per shear plane (with simultaneous embedment failure in inclined areas) and a secondary fastener failure in the shear plane.

As long as the fastener axis is straight, no normal force develops and an MV interaction prevails in the shear plane. When increasing the middle timber thickness, a transition to the failure mechanism with plastic hinges can be observed. Due to the inclined fastener axis, normal forces occur that lead to an MNV interaction in the shear plane. Hence, the influence of different interactions needs to be investigated. For failure mode a) in Fig. 2, the embedment strength f_h is assumed to be achieved across the middle timber, and the moment in the shear plane M_{sp} is smaller than the fastener's yield moment M_y . Here, shear force V (= load-bearing capacity per shear plane F_v) and moment M_{sp} interact, assuming the fastener is clamped in the outer steel plates. The second mode b) in Fig. 2 shows two plastic hinges per shear plane, where the yield moment M_y is reached and the timber in the fastener's inclined section is deformed due to achieving the embedment strength f_h . The force diagram shows the inclined section of length b_1 between the plastic hinges. Due to the fastener's inclination, additional normal forces

Table 1: Test programme.

Number of tests	beech LVL			DVW		
	20	30	60	15	30	60
Timber thickness [mm]	20	30	60	15	30	60
Copper	3	2	1	2	1	
Aluminium	2	1	1	1	1	
Steel C15			2	1	3	1
Silversteel			3	1	2	2

arise, differing at the inner plastic hinge in the middle timber (N_B) and in the shear plane (N_{sp}). In accordance with basic mechanical principles, the shear force in the inner plastic hinge is assumed to be zero. The two bending moments occurring in the middle timber M_B and in the shear plane M_{sp} are assumed not to be equal, as different interactions of internal forces occur. Tested configurations are listed in Table 1. Necessary input parameters of the fasteners such as shear capacity F_{shear} , tensile capacity F_{tens} and yield moment M_y are determined experimentally with 10 samples each.

4 – RESULTS

4.1 MATERIAL PROPERTIES OF DOWELS

Table 2 provides the results for material properties determined experimentally. The ratio of F_{shear}/F_{tens} varies from 58% -76% for tested metals, whereas a ratio for steel is 58%, i.e. $1/\sqrt{3}$, see Eurocode 3 [13]. No metals tested showed a distinct yield zone during tensile tests.

4.2 CONNECTION TESTS

Failure modes and maximum loads reached in the tests are given in Table 3 for each specimen.

Fig. 3 shows exemplary deformed fasteners in opened specimens. All fasteners failed finally in the shear plane. The recorded load-machine deformation (deformation is machine displacement) curves are given in the diagrams, where the initial slip of the machine is eliminated and the curves start at 0.25 kN on the ordinate. Relative displacements between the members are not recorded. To compare the loads achieved in the double-shear connection tests with the shear capacity of the dowels, the results of the shear tests on the dowels are included with grey dots. In DVW, all dowels failed due to shear and for some connections, the maximum loads reach the shear capacity of the dowels. Even higher loads than the pure shear capacity are observed for dowels made of steel C15. However, loads exceeding the shear capacity can only be reached if additional friction develops in the shear planes, which suggests that some level of contact must have occurred within the shear plane due to embedment deformation taking place "out-of-plane" of the timber. A representative example of this phenomenon is a DVW connection with C15 dowels, see Fig. 3, where deformed timber fibres close the gap and thereby generate contact between steel plate and timber surface. This additional contact likely enhances the connection's overall load-bearing capacity. However, these specific tests will not be addressed any further in this study.

Table 2: Material properties of tested dowels.

	F_{shear}	F_{tens}	f_u	M_y (45°)	F_{shear}/F_{tens}
	kN	kN	MPa	Nm	%
Copper	5.62	9.70	342	13.0	58.0
Aluminium	7.40	12.0	424	16.5	61.6
Steel C15	12.6	20.1	711	27.5	62.5
Silversteel	15.5	20.3	719	29.5	76.1

Table 3: Load-bearing capacities in kN with corresponding failure modes, timber thickness in mm.

	Thickness					Failure mode
		Copper	Aluminium	Steel C15	Silversteel	
beech LVL	20	5.22				Splitting timber, shear failure fastener
		5.57				Slight formation of plastic hinges, shear failure fastener
		5.34				Splitting timber
	30		4.93			
			4.94			
	60	5.07				Plastic hinges
5.25					Plastic hinges	
6.00					Plastic hinges, Pull-in of fastener at large deformations	
5.42		5.78	11.3	11.3		
DVW	15	5.42				Shear failure fastener
		5.46				Slight formation of plastic hinges, shear failure fastener
		7.11		13.2	15.8	Plastic hinges, Pull-in of fastener at large deformations
	30	5.77				Shear failure fastener
		7.40				Plastic hinges, shear failure fastener
			13.8	13.5	12.7	
	60			15.9	15.2	
			14.3			
				14.7	15.3	

In general, lower load-bearing capacities are reached for connections with beech LVL compared to DVW. A peculiarity of some connections with copper and aluminium dowels is the splitting of the test specimens in grain direction, even with increased end grain distances. This only occurred for a timber thickness of 20 mm and is marked with green dashed lines in Fig. 3. In case of fastener inclination, the first failure is embedment failure occurring simultaneously with the formation of plastic hinges. Depending on the displacement of the connection and the ratio of embedment strength to fastener strength, fastener failure in the shear plane follows at a later stage (e.g. beech LVL connections in Fig. 3). A straight fastener axis, as seen in the DVW connection with copper or aluminium, only allows for embedment failure and/or fastener failure in the shear plane without additional deformation effects. In that case, the load-bearing capacity per shear plane more or less corresponds directly to the fasteners' shear capacity F_{shear} . The results show a lower load-bearing capacity for connections with inclined fasteners when compared to those with straight fasteners. Copper dowels in beech LVL, for example, exhibit distinct plastic behaviour with a transition from elastic to plastic connection behaviour at lower loads compared to the shear tests. The behaviour of copper in DVW connections, instead, is quite similar to that observed in a shear test comparable to a conventional steel-to-steel connection, where pure shear failure of the fasteners is typically observed. The ultimate load of these connections then corresponds directly to the shear capacity of the dowels, as indicated with grey dots in Fig. 3. However, a lower embedment strength of beech LVL results in an inclined axis of the copper fasteners. Hence, a rope effect develops and consequently results in the yield limit being reached prematurely. For the other metals tested, this effect is amplified.

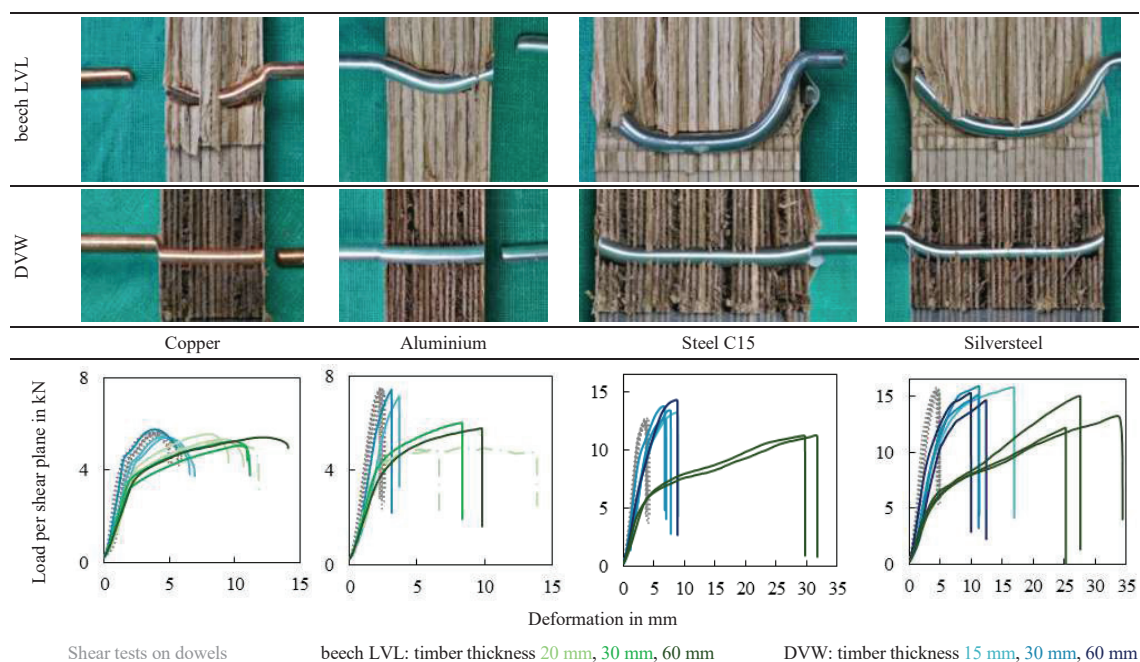

Figure 3: Deformed fasteners and failures for different dowels in beech LVL (1st line) and DVW (2nd line) with test results per shear plane below.

5 – DISCUSSION

Different fastener deformations observed lead to different internal forces and moments occurring in the fastener. To apply the interaction criterion presented in (1), an analytical approach for failure mode a) acc. to Fig. 2 is explained in the following. For calculations, mean values are used. As a first step, the load-bearing capacity is calculated acc. to Eurocode 5 [14] for all tested connections for the failure modes shown in Fig. 2, i.e. embedment failure of the middle timber or failure with two plastic hinges per shear plane. Here, mean values are used, see also Table 2. Exemplary calculations for aluminium (timber thickness 30 mm) are shown in Fig. 4. Ellipses included in the diagrams mark the test results. The minor axis of the ellipse marks the min/max load reached, whereas the major axis marks the range of possible embedment strength with a certain scattering. Aluminium in beech LVL develops two plastic hinges per shear plane and fails due to shear afterwards, see Fig. 4a. The test results in a load of 6 kN per shear plane, which is similar to the calculated load-bearing capacity acc. to Eurocode 5 [14]. Because of the inclined fastener sections between the plastic hinges in beech LVL, an additional line with an included rope effect is given in the diagrams, see dashed green line. In contrast to this, the axis of the fastener in DVW stays almost straight and a clear shear failure occurs, see Fig. 4b. The load reached in the test is exactly the same as the shear capacity of the aluminium dowel, see blue line in Fig. 4. If the load-bearing capacity is calculated acc. to Eurocode 5 [14], the load per shear plane exceeds the shear capacity as soon as the embedment strength is higher than 140 N/mm² (failure mode with two plastic hinges per shear plane). Thus, the shear capacity F_{shear} can be taken as an upper limit of the load-bearing capacity of the investigated connections. For a straight fastener axis, i.e. failure mode a) acc. to Fig. 2 and Fig. 4b, an interaction of bending moment and shear force can be formulated. Assuming the dowel to be clamped in the outer steel plates, the moment in the shear plane can be calculated with

$$M_{\text{sp}} = \frac{f_h \cdot d \cdot t_2^2}{12} \quad (2)$$

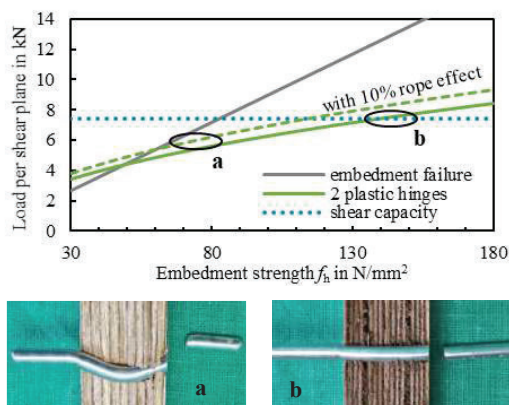

Figure 4: Visualised dependency of different failure modes for aluminium dowels with 30 mm timber thickness.

When inserted into the reduced interaction criterion, the remaining shear force V_{remain} can be calculated as follows:

$$\frac{M_{\text{sp}}}{M_{y,R}} + \left(\frac{V_{\text{remain}}}{F_{\text{shear}}} \right)^2 \leq 1.0 \quad (3)$$

$$\leftrightarrow V_{\text{remain}} \leq F_{\text{shear}} \cdot \sqrt{1 - \frac{f_h d t_2^2}{12 M_{y,R}}} \quad (4)$$

With (4), a reduced shear capacity V_{remain} can be calculated, see Fig. 5. As soon as the embedment stress exceeds 39 N/mm², the shear capacity would be reduced to 0 kN. This reduction is significant and leads to comparably low remaining shear capacities V_{remain} . Hence, for that case, (4) is not useful to calculate the remaining shear capacity because a load approximately equal to the shear capacity is reached in the test. At the same time, the question can be raised of whether the assumptions made are suitable. The occurring moment in the shear plane could be overestimated with the assumption of a fully clamped dowel in the outer steel plates. As a more appropriate assumption, something in between a rigid and an elastic restraint in the steel plates could be discussed. In addition, the assumption of a uniformly distributed embedment stress along the fastener axis is to be questioned. To verify that hypothesis, an exemplary calculation, again exemplarily on the aluminium connection, follows. The shear capacity and load per shear plane reached in the test are equal and amount to 7.4 kN. In order to calculate the load-bearing capacity with an embedment failure, the load per shear plane F_{sp} is calculated with

$$F_{\text{sp}} = \frac{f_h \cdot d \cdot t_2}{2} \stackrel{!}{=} 7.40 \text{ kN} \quad (5)$$

With a dowel diameter of 6 mm and a timber thickness of 30 mm, an embedment stress of 82.2 N/mm² needs to be reached to fulfil the condition. The magnitude of the embedment stress in DVW initially appears realistic. However, when calculating the bending moment in the shear plane with (2), it results in $M_{\text{sp}} = 37.0$ Nm. It becomes obvious that it exceeds the yield moment of the aluminium dowel by far ($M_{y,45^\circ} = 16.5$ Nm, see test results in Tab. 2). Even if a lower clamping effect of the dowel in the steel plates is taken into account, the bending moments along the fastener axis are too high.

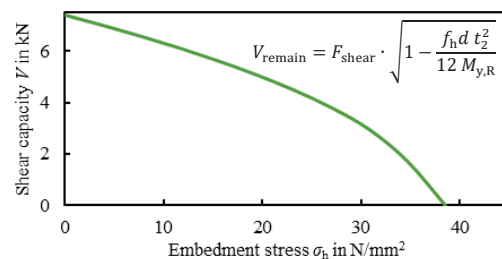

Figure 5: Decrease of remaining shear capacity V_{remain} with higher embedment stress for a connection with aluminium dowel and 30 mm timber thickness. Uniform embedment stress distribution assumed.

Considering the deformed fastener in Fig. 4b, only a slight bending of the fastener can be detected. Thus, the embedment stress must be distributed similarly to a failure mechanism with two plastic hinges per shear plane. The difference is that the bending moment does not reach the amount of the yield moment at any point along the fastener axis. This leads to the assumption that the full plastic bending is not yet reached.

Generally speaking, the higher the strength of the timber material, the higher the embedment stresses in the area of the shear plane. And, the areas with high embedment stress become progressively smaller and have a decisive effect on the magnitude of the shear force acting in the fastener in the shear plane. This becomes clearer when comparing the distributions in Fig. 6. The embedment stresses $\sigma_{h,1}$ and $\sigma_{h,2}$ shown are defined to be $\sigma_{h,1} > \sigma_{h,2}$ for each case to show how they differ from one another. For the case shown on the left, it is assumed that the embedment strength is achieved in certain areas near the shear plane, see partially constant stresses $\sigma_{h,1}$, and, in centre part the stress $\sigma_{h,2}$ is below the embedment strength. For the case shown on the right, by contrast, the embedment stresses are assumed to remain below the embedment strength.

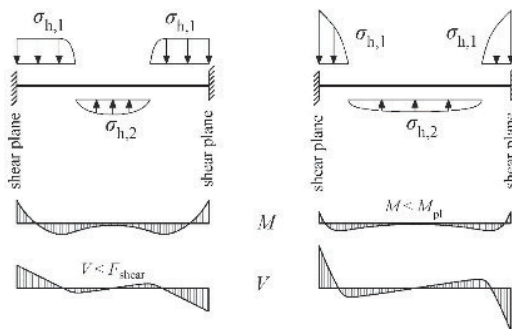

Figure 6: Qualitative distributions for shear force V and bending moment M for high density timber on the left and very high density timber on the right.

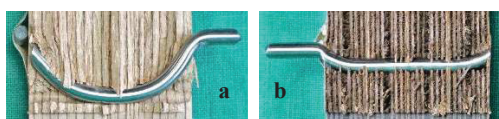
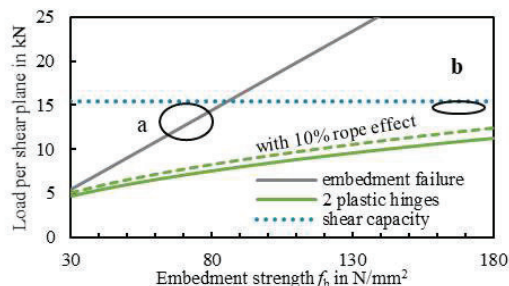

Figure 7: Visualised dependency of different failure modes for silversteel dowels with 60 mm timber thickness.

The left case stands for a typical steel-to-timber connection, where the bending moments reach the yield moment and plastic hinges develop. Increasing the embedment strength leads to higher stresses in a smaller area close to the shear plane, eventually causing higher shear forces and lower bending moments acting in the shear planes, see Fig. 6 on the right. As no clear plastic hinge is visible in the exemplary connection, see Fig. 4b, the bending moment does not reach the yield moment. Considering the test results no reduction in shear capacity due to the bending moment can be observed as the connection capacity is equal to the dowel's shear capacity F_{shear} . Consequently, this means that in Fig. 6 on the right, the occurring bending moment M is so small that there is no influence of the interaction of shear and bending [6]. If other failure modes, as shown in Fig. 4a and 7, are also considered, it becomes clear that the distributions shown in Fig. 6 are nevertheless only partially appropriate. There is a smooth transition between the two shown distributions and corresponding failures. When plastic hinges are visible, and bending in the fastener dominates, the moments increase from the elastic to the plastic range. Only the left case can be used then. In contrast, the inclined orientation of the fasteners between the plastic hinges generates a normal force, which has not yet been taken into account, cf. e.g. [11] and [12]. The normal force causes an increase in the connection load-bearing capacity due to the rope effect, whereas the effects on the fastener itself have not been investigated further. However, the results shown here indicate which effects are possible. The normal force creates additional normal stress components in the fastener. These, together with the components from the bending moment and the shear stresses caused by the shear force, can lead to failure in the shear plane before the shear capacity is reached, see Fig. 3. A comparison of the reached load-bearing capacities shows the magnitude of the reduction. For aluminium in beech LVL, a load-bearing capacity of approx. 80% of F_{shear} is reached. The results for silversteel dowels scatter rather more and result in a load-bearing capacity in the range of 79 - 97% of the shear capacity. It could be assumed that a more inclined position of the fastener would result in higher normal forces and thus, leading to a greater reduction in load-bearing capacity. Therefore, the impact of normal forces on the interaction between internal forces and moments in fasteners subjected to lateral loads is a crucial aspect to consider. Normal forces are particularly important because, in the case of pure normal stress, the cross-section does not have any plastic reserve. This means that all fibres in the cross-section will reach the yield strength simultaneously, assuming a uniform strength distribution across the cross-section. As a result, the behaviour of a laterally-loaded fastener becomes more complex, and understanding how these normal forces interact is essential for an accurate calculation of the load-bearing capacity of a connection. Simultaneously, increased inclination of fasteners and normal forces enhance the rope effect and lead to an increased load-bearing-capacity of a connection. However, the tests carried out could not rule out the possibility of frictional effects. Higher loads than the shear capacity can only be achieved with additional friction in the shear planes. Thus, there must have been

contact in the shear plane due to embedment deformation “out-of-plane” of the timber. This effect occurred with steel C15 and silversteel in beech LVL. The magnitudes of the normal forces acting in laterally loaded fasteners remain uncertain at this stage, and this uncertainty highlights the need for further investigation. Understanding their exact magnitudes is essential for accurately predicting the load-bearing capacity of connections.

6 – CONCLUSION

Tailor-made tests investigating the effect of an interaction between internal forces and moments in fasteners on the load-bearing capacity of connections with laterally loaded fasteners are carried out. These tests led to different conclusions for two possible types of interaction, namely *MV* interaction and *MNV* interaction highlighting their distinct influence on connection performance. A constant distribution of embedment stress across the fastener would only be applicable in case of a particularly stiff fastener embedded in a comparatively soft timber. However, this condition is not fulfilled for any of the cases investigated in this study. For an extreme case, such as copper dowels in DVW, the opposite scenario is observed: a very soft fastener embedded in a high-strength timber material behaves similarly to a typical steel-to-steel connection, where the fastener ultimately fails due to pure shear without significant embedment effects. Higher connection capacities than the shear capacity of the fasteners are occasionally observed in tests and are attributed to an additional frictional component developing between the timber and the steel plate. The magnitude of this frictional contribution remains uncertain and cannot be precisely quantified based on the experiments. Based on the test results, the interaction between bending moment and shear force appears to have only a minor influence on the overall load-bearing capacity. In contrast, normal forces must be present when fasteners are inclined and ultimately, the *MNV* interaction leads to a reduced load-bearing capacity. The question arises how normal forces influence the interaction between internal forces and moments in laterally loaded fasteners. Normal forces are particularly critical since, under pure normal stress conditions, no plastic cross-sectional reserve exists, meaning that all fibres in the fastener reach the yield point simultaneously, assuming a uniform strength distribution across the cross-section. The exact magnitudes of the normal forces acting in laterally loaded fasteners remain unknown. Given their crucial role in influencing the load-bearing behaviour, these forces should be investigated further in future research to improve the understanding of their contribution to load-bearing capacities of connections and their failure mechanisms.

7 – ACKNOWLEDGEMENT

This work has been carried out within the project *hardwood_joint* that is supported under the umbrella of ERA-NET Cofund ForestValue by BMLFUW (AT), ADEME (FR), FNR (DE) and Vinnova, Swedish Energy Agency and Formas (SE). ForestValue has received funding from the European Union’s Horizon 2020 research and innovation programme under grant agreement N° 773324.

8 – REFERENCES

- [1] C. Sandhaas. “Mechanical Behaviour of Timber Joints with Slotted-in Steel Plates.” PhD thesis, TU Delft, 2012.
- [2] P. Kobel. “Dowel-Type Connections in Beech LVL.” PhD thesis, ETH Zurich, 2019.
- [3] H. J. Blaß, C. Sandhaas und N. Meyer. “Steel-to-timber connections: Failure of laterally loaded dowel-type fasteners.” Proceedings of INTER, Meeting 50, Kyoto, Japan, 2017.
- [4] E. Kuck, C. Sandhaas. “Load-bearing behaviour of partially threaded screws in hardwood.” Wood Material Science & Engineering, pages 283–298, 2022. DOI: 10.1080/17480272.2022.2084453.
- [5] N. Meyer. “Tragfähigkeit mechanischer und geklebter Verbindungsmittel in Buchenfurnierschichtholz.” PhD thesis, Karlsruhe Institute of Technology, 2021.
- [6] J.W. Roderick. “LXV. Theory of plasticity - elements of simple theory.” The London, Edinburgh, and Dublin Philosophical Magazine and Journal of Science, 7 (39:294):529–539, 1948. DOI: 10.1080/14786444808521666.
- [7] M. R. Horne. “The Plastic Theory of Bending of Mild Steel Beams with Particular Reference to the Effect of Shear Forces.” In Proceedings of the Royal Society of London, volume 1089, p. 216–228, 1951.
- [8] D. C. Drucker, W. Prager and H. J. Greenberg. “Extended limit design theorems for continuous media.” Quarterly of Applied Mathematics, 9(4):381–389, January 1952.
- [9] D. C. Drucker. “The Effect of Shear on the Plastic Bending of Beams.” Journal of Applied Mechanics, p. 509–514, 1956.
- [10] H. J. Blaß. Moment-Normalkraft-Querkraft Interaktion in stiftförmigen Verbindungsmitteln von Stahlblech-Holz-Verbindungen. In Proceeding of Karlsruher Tage HOLZBAU Forschung für die Praxis, pages 17–26. KIT Scientific Publishing, October 2018.
- [11] K. W. Johansen. “Theory of Timber Connections.” IABSE: International Association of Bridge and Structural Engineering, 9, Basel, Switzerland, 1949.
- [12] A. Meyer. “Die Tragfähigkeit von Nagelverbindungen bei statischer Belastung.” In: Holz als Roh- und Werkstoff: European Journal of Wood and Wood Industries 15 (2), 1957. DOI: 10.1007/BF02609174.
- [13] EN 1993-1-1:2010 Eurocode 3: Design of Steel Structures - Part 1-1: General Rules and Rules for Buildings. European Committee for Standardization (CEN).
- [14] EN 1995-1-1:2010 Eurocode 5: Design of Timber Structures – Part 1-1: General – Common Rules and Rules for Buildings. European Committee for Standardization (CEN).