

Nuno Vilhena, Anabela Pronto, João Murta-Pina, Roberto Oliveira, Pedro Arsénio

Centre for Technologies and Systems (CTS) – UNINOVA, Dept. of Electrical Engineering (DEE),  
Faculdade de Ciências e Tecnologia, Universidade Nova de Lisboa (FCT NOVA), Portugal  
amg1@fct.unl.pt

## Abstract

Asymmetric faults, namely phase to ground, are the most common in distribution grids. To adopt superconducting based technologies, namely superconducting fault current limiters (SFCL), utilities must be aware of the performance of these devices under such events, where a fault in e.g. a single phase may impact healthy ones. This performance is evaluated in this work in low voltage prototypes, namely three-phase inductive FCLs of transformer type where distinct magnetic circuits are applied, i.e. shell- vs. core-type laminations. In the latter, a conventional three-legged transformer core is used in the limiter, while in the former a five-legged core is employed, providing a low reluctance path for magnetic flux due to asymmetric faults, thus preventing it from affecting healthy phase(s). The performance of the devices is analysed under distinct asymmetric (and symmetric) faults, in order to provide guidelines for choosing the optimum configuration regarding also cost, weight and volume.

## Problem and Solution

A single-phase short-circuit may affect “healthy” phases.

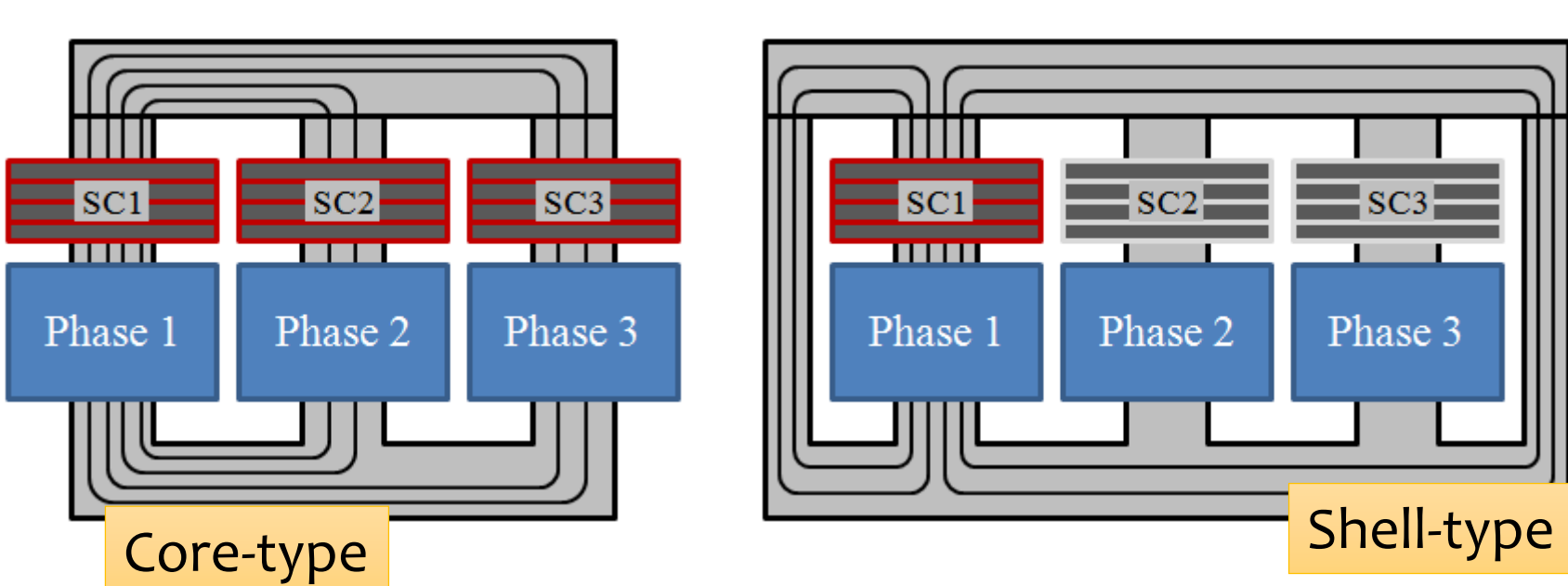

A shell-type core provides an alternative path for magnetic flux, protecting “healthy” phases.

## Developed prototype

A reconfigurable ferromagnetic core (two movable upper yokes) is used to implement core and shell-type laminations.

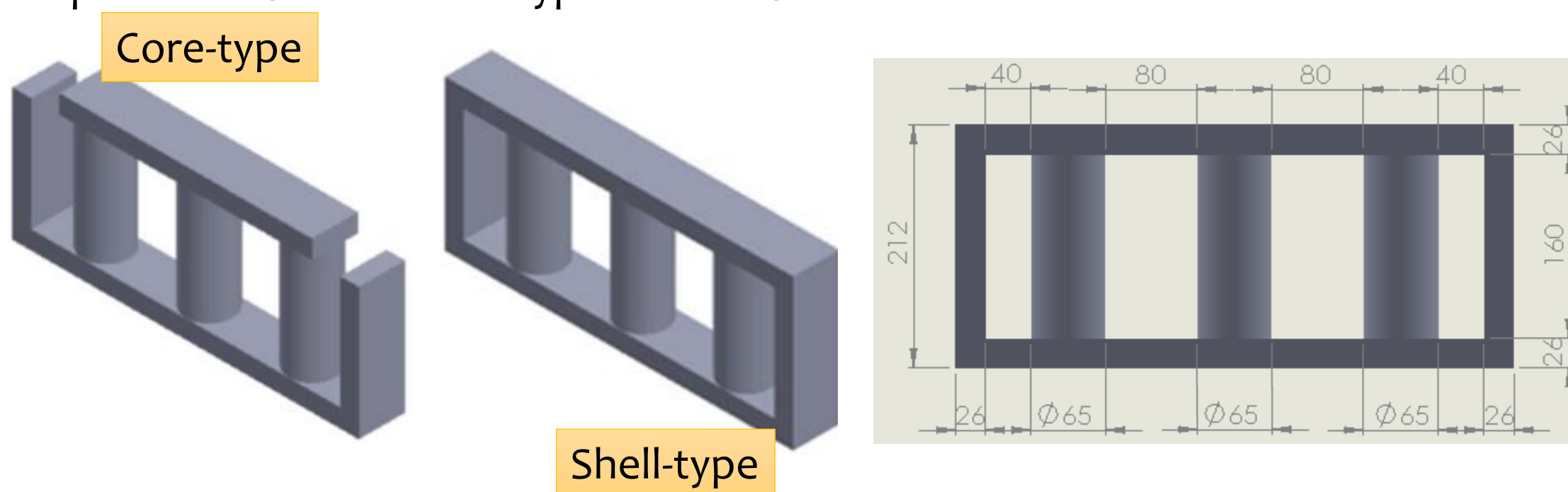

## Test circuit

A set of controlled circuit breakers allow simulating distinct types of faults, namely:

- Line-to-ground.
- Line-to-line.
- Double line-to-ground.
- Three-phase.

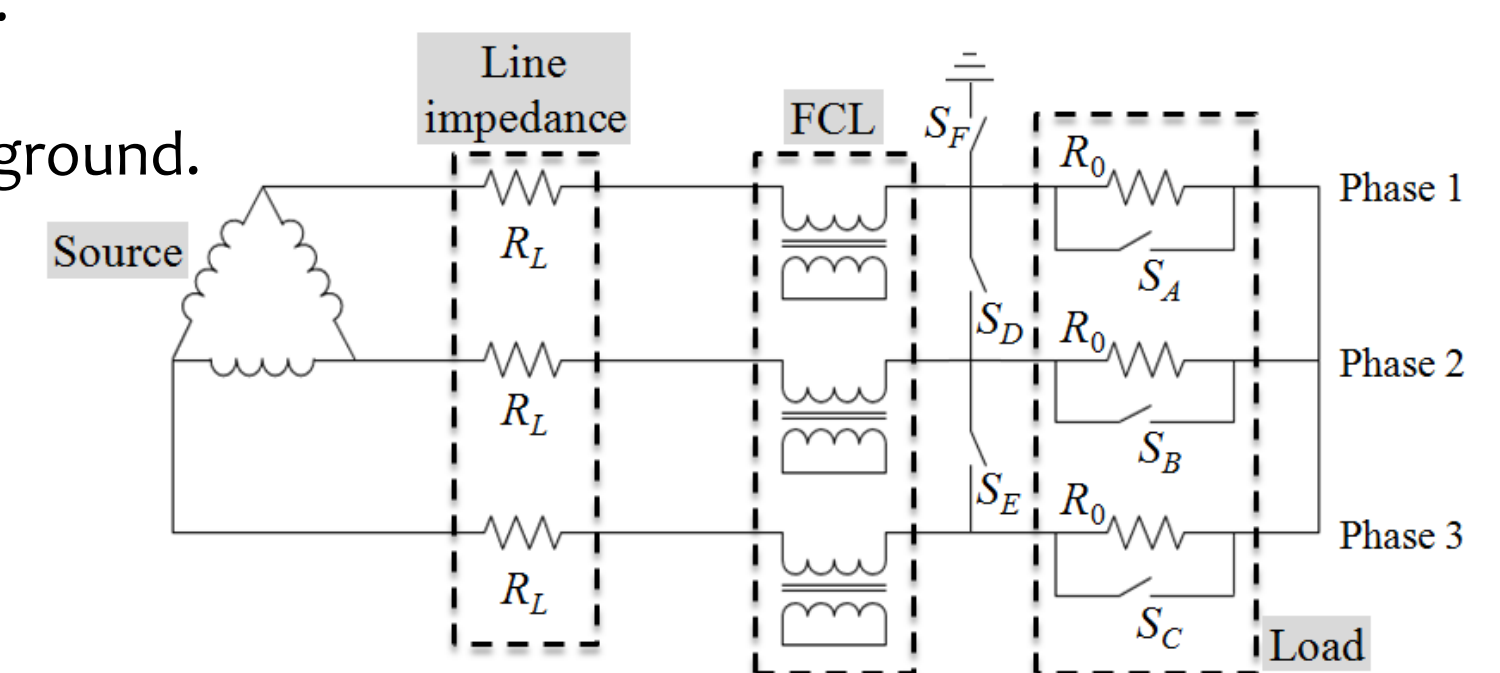

## Faults

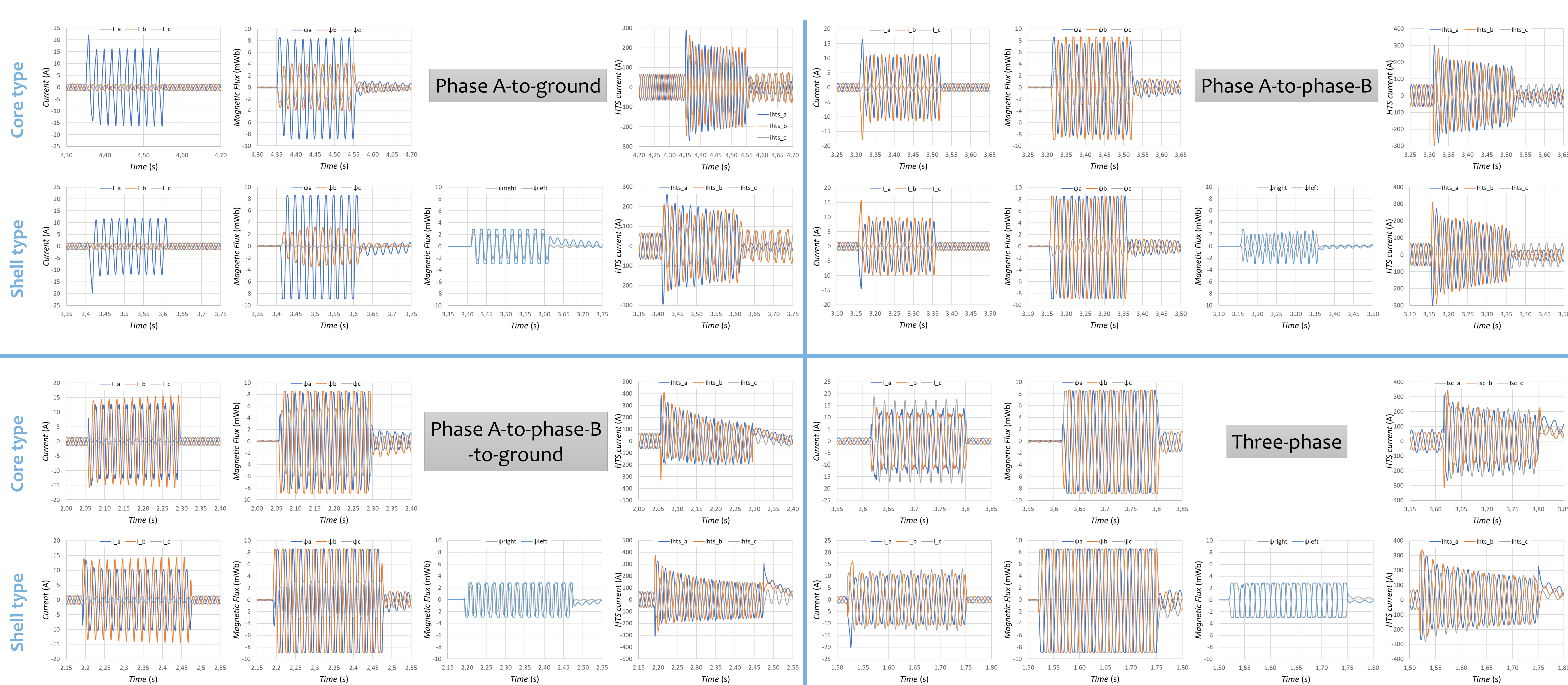

## Prototype

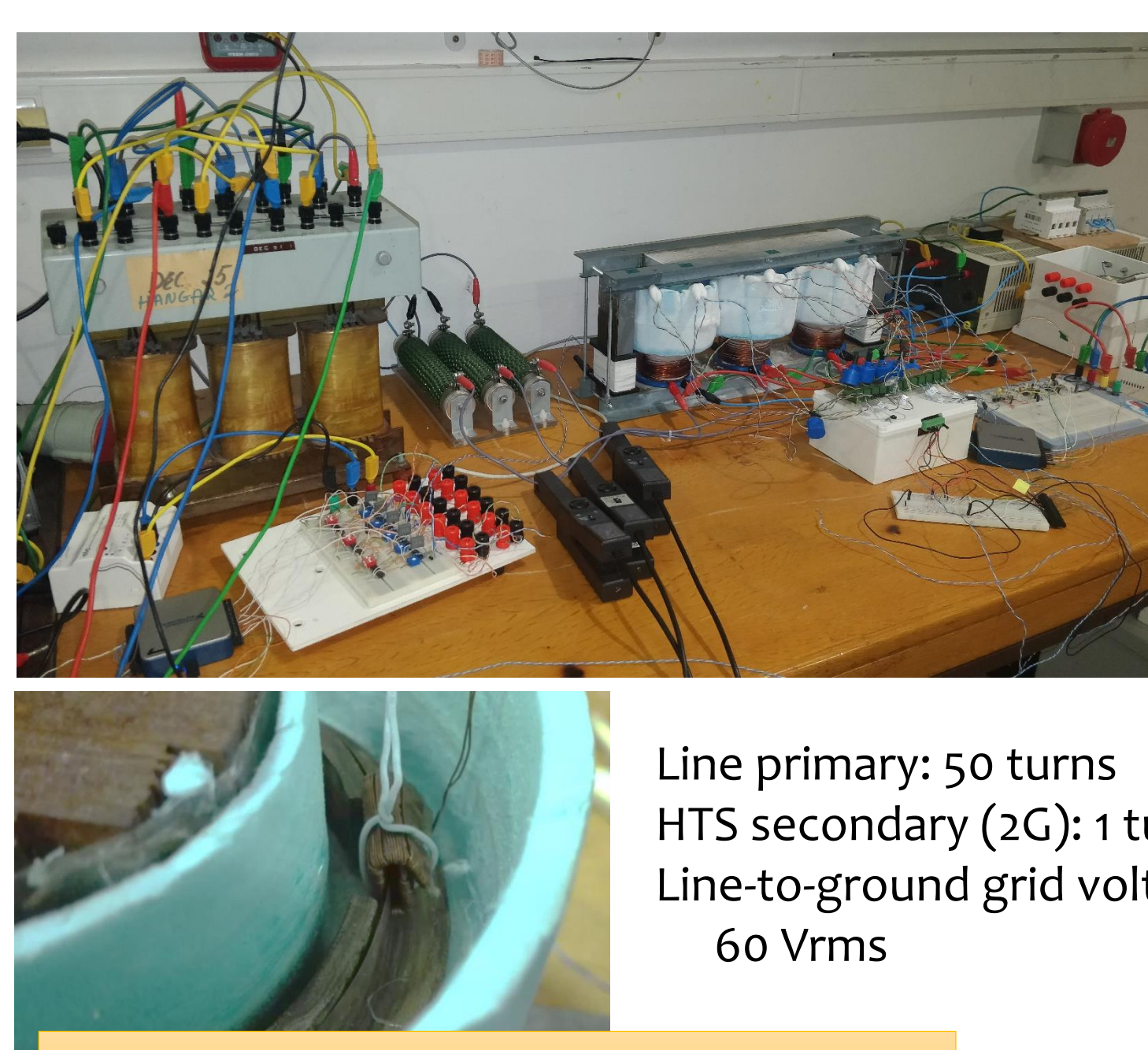
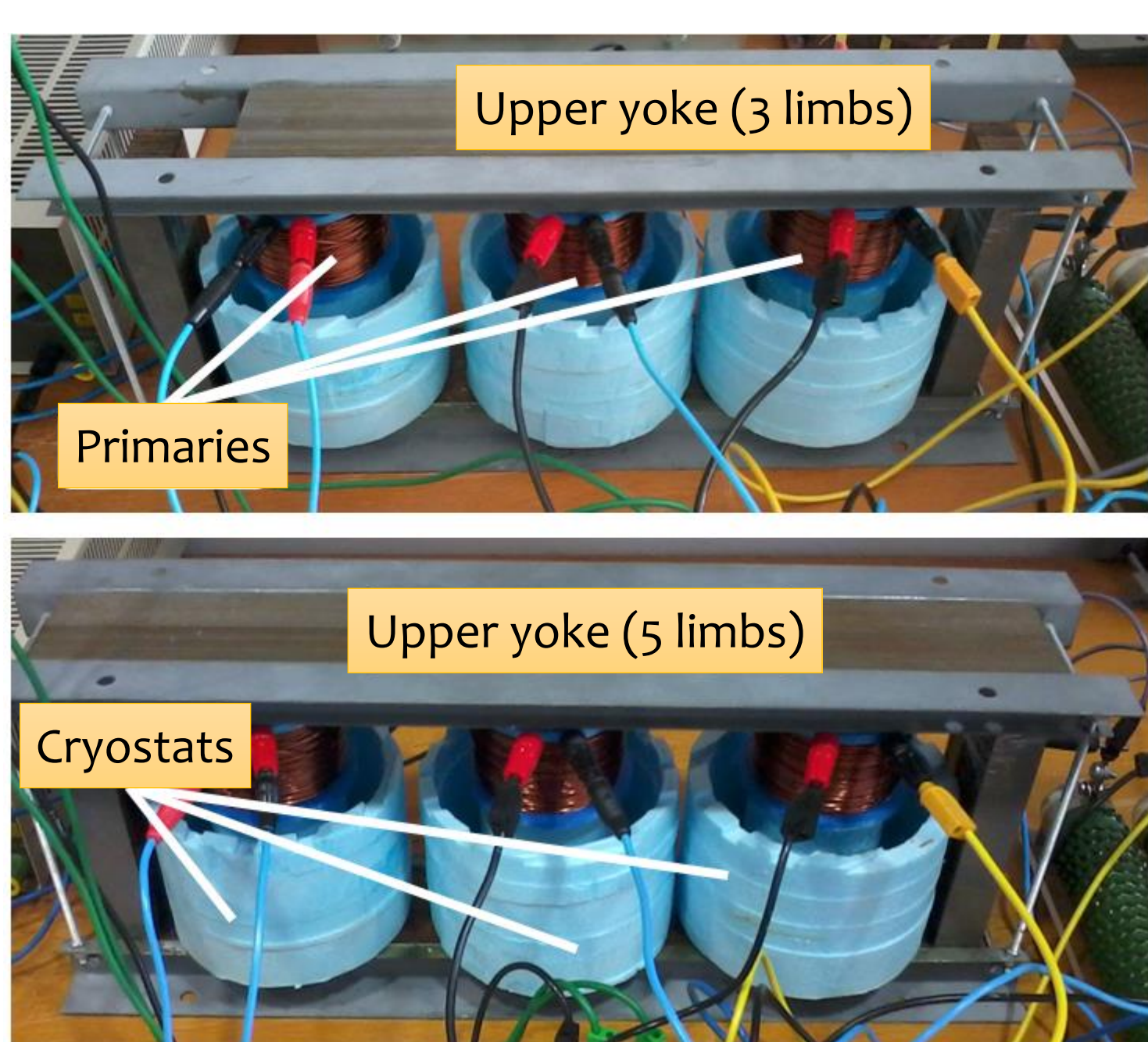

Line primary: 50 turns  
HTS secondary (2G): 1 turn  
Line-to-ground grid voltage:  
60 Vrms

Rogowsky coil for measuring HTS current

## Conclusions and future work

- A reconfigurable magnetic core was implemented to assess the performance of two distinct laminations in a SFCL.
- Shell-type lamination leads to improved limitation in all faults.
- Healthy phases are less affected in shell-type lamination, under asymmetric faults, than in core-type.
- Improved performance at the cost of additional iron: optimisation methodology needs to be developed.
- In single-phase faults, the magnetic circuit plays a role in the behavior of the limiter. This requires further optimisation.