

A SUPERCONDUCTING SWITCH FOR INSERTION DEVICES WITH VARIABLE PERIOD LENGTH

T. Holubek*, T. Baumbach, S. Casalbuoni, S. Gerstl, A. Grau, M. Hagelstein, D. Saez de Jauregui, ANKA, Karlsruhe Institute of Technology, Karlsruhe, Germany
C. Boffo, W. Walter, Babcock Noell GmbH, Würzburg, Germany

Abstract

Superconducting insertion devices (IDs) are very attractive for synchrotron light sources since they offer the possibility to enhance the tuning range and functionality significantly by period length switching. Period length switching can be realized by reversing the current in a separately powered subset of the superconducting windings.

So far, the first demonstration mock-up coil allowing period length tripling was fabricated and tested successfully. Here, we report on the feasibility of superconducting switches built to operate in a liquid helium bath and under conduction cooled conditions.

INTRODUCTION

Switching the period length allows to increase the tunability of an insertion device. Using permanent magnet technology, this is realised in the so-called revolvers [1], interchanging more magnetic structures mechanically. In superconducting undulators this can be achieved by reversing the current in a separately powered subset of the superconducting windings [2]. This idea is being implemented at ANKA [3, 4] for a device intended for the IMAGE beamline. Switching will be between a 18 mm period undulator and a 54 mm period length wiggler. We proved the feasibility of period length switching using a 9 pole mock up designed and manufactured by BNG and showed that there is no need to retrain the magnet after each switch [5].

In order to use only one power supply instead of two for the two circuits, reducing the thermal input to the device, work is ongoing at ANKA to develop a superconducting switch (SCS) [6]. Here we report on two SCSs made with NbTi wire and constructed upon the classical electrical bridge concept. Instead of employing electrical resistors, the resistance of each circuit-branch is controlled thermally by a heater in good thermal contact with the circuit-branch to be switched from the superconducting to the normal state. The first SCS to work in a liquid helium bath has been built following reference [6]. The results of the tests are reported in section 2. For our application to cryogen free superconducting insertion devices a second SCS to work in conduction cooled conditions has been built and tested: the results are presented in section 3. To demonstrate the feasibility of both SCSs we have tested them connected to the 9 pole mock up (COIL) described above (see figure 1).

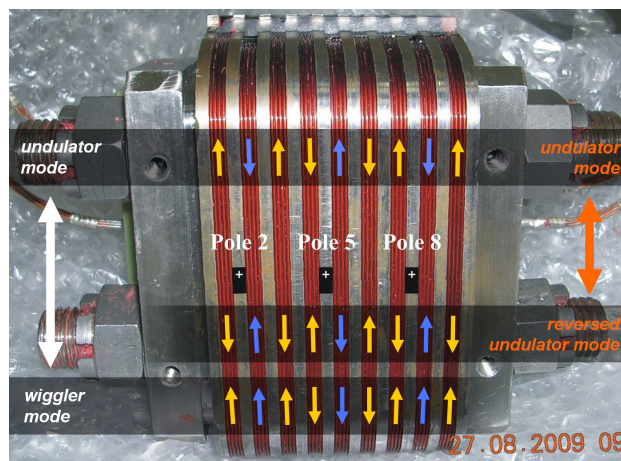

Figure 1: The 9 pole mock-up (COIL) used to demonstrate the feasibility of period length switching in superconducting insertion devices [5]. The arrows represent the current direction in the winding while the arrow color distinguishes between circuits L1 and L2. Three Hall probes were placed on the poles 2, 5 and 8.

SCS WORKING IN LIQUID HELIUM

SCS Construction

The SCS built to work in liquid helium, is counting four circuit-branches, made of electrically insulated NbTi superconducting wire, manufactured by European Advanced Superconductors GmbH [7]. All the branches are equipped with heaters, made of resistive, electrically insulated CuMn wire, wrapped around the branches in one layer. As proposed by Madur et al. [6], the heater section is further encapsulated and filled with epoxy to form a 30 mm long cylinder with a diameter of 12 mm.

Measurement Setup

The measurement setup, shown in figure 2, is made by two electrically separated circuits, housed in the liquid helium cryostat and powered from outside by two power supplies. One power supply PS1 with maximum output current of 1500 A is used for the superconductive branches of the switch and the COIL, and the other one PS2, a precise current source with the maximum output of 3 A, is used for the heaters. In circuit 1, the nodes N1 and N2 of the switch are soldered to the current leads of the COIL, whose subsets L1 and L2 are connected in series in the undulator mode. Nodes N3 and N4 of the switch are

soldered to the leads L^+ and L^- of the power supply PS1. Since the current flows through the NbTi SCS branches, the current direction in L1 and in L2 is determined by the heaters, controlled in circuit 2.

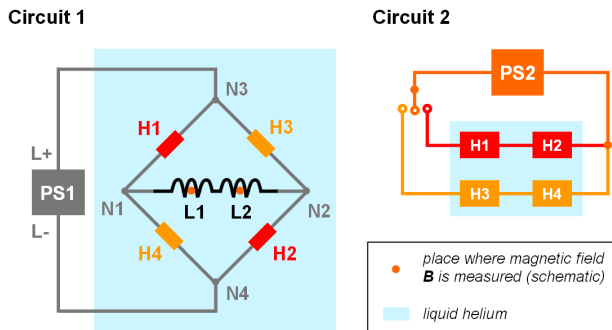

Figure 2: Measurement setup used to test the SCS built to work in liquid helium.

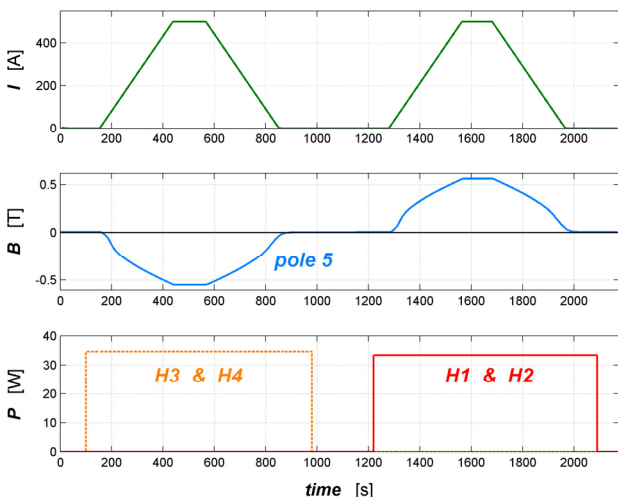

Figure 3: Test of SCS working in liquid helium – the current from PS1, the field measured by the Hall probe located at pole 5 and the heaters power versus time are shown.

SCS Operation

The test has been performed in the liquid helium bath cryostat CASPER at ANKA [8]. The operation of the SCS is described in figure 3, where the current through circuit 1, the magnetic field seen by the Hall probe located at pole 5 of the COIL and the power generated by the heaters versus time are plotted.

In figure 3 it is demonstrated that it is possible to change the direction of the current in the coils, as shown by the opposite sign of the field measured with the Hall probe located at pole 5, when heating first H3 and H4 and then H1 and H2. When H3 and H4 (H1 and H2) are heated, the superconducting wire in the respective branches undergoes to the normal state inhibiting the flow of current between N2 and N3, and N1 and N4 (between

N3 and N1, and N2 and N4), and thus, the current in circuit 1 flows as follows: $L^+ \rightarrow N3 \rightarrow N1 \rightarrow L1 \rightarrow L2 \rightarrow N2 \rightarrow N4 \rightarrow L^-$ ($L^+ \rightarrow N3 \rightarrow N2 \rightarrow L2 \rightarrow L1 \rightarrow N1 \rightarrow N4 \rightarrow L^-$).

The amount of heat needed to drive two opposite branches of the SCS from superconducting to normal conducting state is in this case 35 W. This is due to the high cooling power of liquid helium.

CONDUCTION COOLED SCS

SCS Construction

The SCS to work under conduction cooled conditions has been built to be tested in the upper part of the liquid helium cryostat CASPER, surrounded by helium gas. All four branches of the conduction cooled switch are glued with epoxy to four Cu bars, partially immersed in liquid helium. The function of the Cu bars is to provide a thermal connection between the coolant and the branches. For this test the coolant was liquid helium. In a conduction cooled cryostat the Cu bars must be connected by Cu braids to the second stage of a cryocooler. The switch-branches are constructed with electrically insulated NbTi superconducting wire, manufactured by SUPERCON, Inc. [9]. The heater elements are realized in the same way as described in section 2.1. They are located in the middle of the branches and are glued with epoxy to the Cu bar. To minimize heat transfer between the switch branches by convection of the helium gas, all the parts of the switch sticking out of the liquid helium are housed in a thermally insulating material.

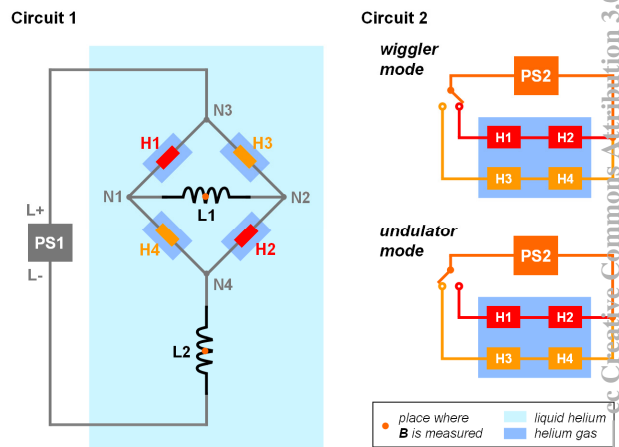

Figure 4: Measurement setup used to test the SCS built to work under conduction cooled conditions.

Measurement Setup

The measurement setup to test the functionality of the conduction cooled SCS is described in figure 4. The COIL is fixed at the bottom of the cryostat, immersed in liquid helium. The coil-subset L1 has been connected to the opposite nodes of the switch, N1 and N2, while L2

has been connected in series with the switch, so that one end is connected to the node N4 and the other to the power supply PS1 at L⁻. The other lead L⁺ of the power supply PS1 has been connected to the node N3 of the switch. Switching the COIL between undulator and wiggler mode has been performed by powering the heaters H1 and H2, and H3 and H4, respectively.

SCS Operation

The direction of the current is changed only in the coil-subset L1. This allows switching the period length of the COIL from 15 mm to 45 mm (see figure 1).

The procedure for the switch operation has been already described in detail in section 2.3. When circuit 2 is closed and heaters H1 and H2 are powered, the COIL is in the wiggler mode and the current flows as follows: L⁺ → N3 → N2 → L1 → N1 → N4 → L2 → L⁻ (see figure 4). When heaters H3 and H4 are powered, the COIL is in the undulator mode and the current flowing through L1 is reversed: L⁺ → N3 → N1 → L1 → N2 → N4 → L2 → L⁻ (see figure 4).

So far, we have tested the operation of two different conduction cooled SCS branches (figure 5). While the first one was cooled by a massive Cu bar with a transverse cross section area of 120 mm², the second branch was cooled by a much thinner Cu strip with a transverse cross section area of 5 mm². For the SCS branch realized with thick Cu bars 16 W are needed to switch the state of the branch from superconducting to normal. For the SCS built with thinner Cu bars only 400 mW are needed.

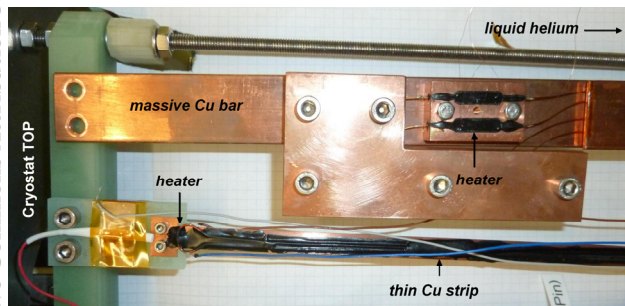

Figure 5: Picture of two different conduction cooled SCS branches.

CONCLUSIONS AND OUTLOOK

We have demonstrated successful operation of the SCS built to work in liquid helium. Furthermore, we have tested two different SCS branches working under conduction cooled conditions. In case of the switch working in liquid helium, a heat of 35 W is needed for its operation. Applications to conduction cooled cryogen free insertion devices as the ones under development at ANKA [10] make use of cryocoolers, which have typically a cooling power of 1-1.5 Watts at 4K. For this reason, for our application we need a SCS which must not

dissipate more than a fraction of a Watt. The tests performed on the conduction cooled SCS branches showed that it is possible to control SCS branches with a power more than 40 times smaller than the one required for the SCS branches cooled by liquid helium. Further tests are foreseen in a cryogen free environment in the facility CASPERII at ANKA [11].

REFERENCES

- [1] J. Chavanne, G. Le Bec, L. Goirand, C. Penel, F. Revol, Proceedings of IPAC'10, Kyoto, Japan
- [2] S. Prestemon, R. Schlueter, S. Marks, and D. R. Dietderich, IEEE Trans. on App. Supercond., vol. 16, no. 2, June 2006, pp. 1873 - 1876
- [3] B. Kostka, R. Rossmannith, D. Wollmann, M. Hagelstein, A. Bernhard, T. Baumbach, M. Weißer, E. Steffens, *Proceedings of PAC05*, Knoxville, Tennessee, USA (2005)
- [4] A. Bernhard, D. Wollmann, S. Casalbuoni, M. Hagelstein, M. Kläser, B. Kostka, R. Rossmannith, Th. Schneider, F. Schöck, M. Weißer, E. Steffens, T. Baumbach, *Proceedings of EPAC06*, Edimburgh, Scotland (2006)
- [5] A. Grau, T. Baumbach, S. Casalbuoni, S. Gerstl, M. Hagelstein, D. Saez de Jauregui, C. Boffo, W. Walter, *IEEE Trans. Appl. Supercond.*, **21** 1596 (2011)
- [6] A. Madur et al, Proceedings of FEL 2009, Liverpool, UK
- [7] www.bruker-est.com
- [8] E. Mashkina, A. Grau, Th. Schneider, A. Bernhard, S. Casalbuoni, M. Hagelstein, B. Kostka, R. Rossmannith, E. Steffens, D. Wollmann, T. Baumbach, *Journal of Physics: Conf. Series* 97 (2008) 012020
- [9] www.supercon-wire.com
- [10] S. Casalbuoni, T. Baumbach, S. Gerstl, A. Grau, M. Hagelstein, T. Holubek, D. Saez de Jauregui, C. Boffo, W. Walter, *SYNCHROTRON RADIATION NEWS*, 14-19 Vol. 24, No. 3, 2011
- [11] A. Grau, T. Baumbach, S. Casalbuoni, S. Gerstl, M. Hagelstein, D. Saez de Jauregui, *IEEE Trans. on Appl. Supercond.* 2312-2315 Vol. 21-3 (2011)