

# Production of real-size parts consisting of different W materials using PIM as an alternative joining process

## Activity 4: Material Technologies

WP13-MAT-01-HHFM-04-04/KIT/PS

Reporting period: January 2013 – June 2013

Principal Investigator: Steffen Antusch

KIT-IAM

Contributions:

Tom Barrett, Lorelei Commin, Niklas Denker, Jan Hoffmann, Peter Holzer, Alexander Klein, Wolfram Knabl, Jens Reiser, Michael Rieth, Heinz Walter

# Objective

## Work Programme 2013

### **Goal 2013: Development of a multiphase PIM tool**

1. Development of new Designs for HC + WC Divertor (in close Cooperation with CCFE)
2. Engineering and design of a new multiphase PIM tool
3. Production of parts with the new tool
4. Adaption of the heat-treatment process (in close cooperation with PLANSEE SE)
5. Characterization of mechanical and physical properties (in close cooperation with OXFORD Materials)
6. HHF testing (in close cooperation with FZ Jülich and IPP Garching) and characterization after testing

# The idea of a multiphase PIM tool...

...only one PIM tool...

Producing of parts with variable shapes

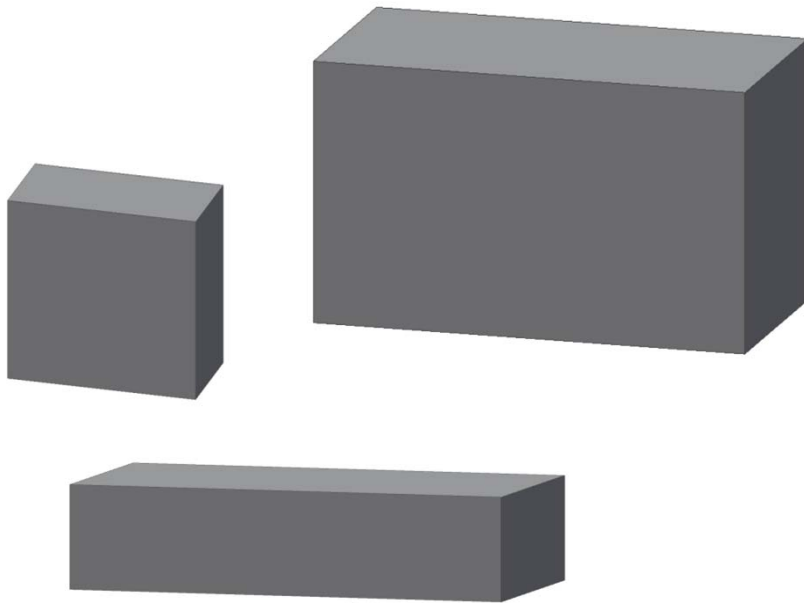

Joining of different materials

Integration of interlayer

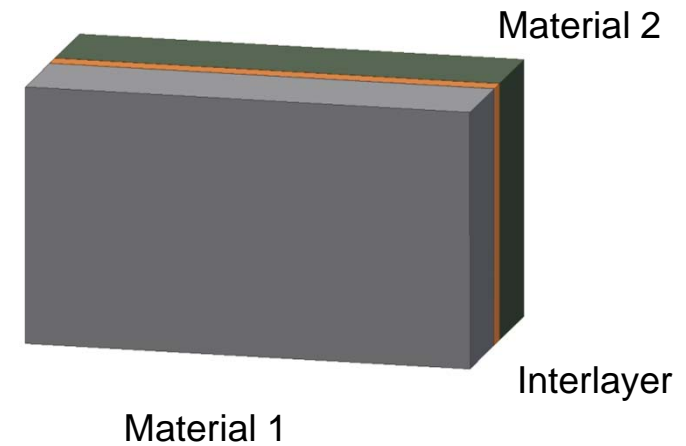

(1) Development of new designs for HC and WC Divertor (in close cooperation with CCFE)

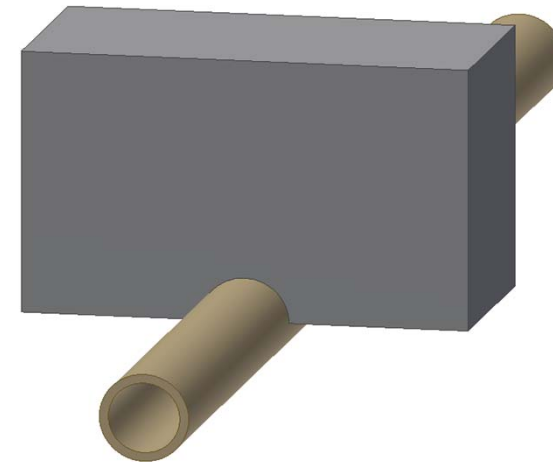
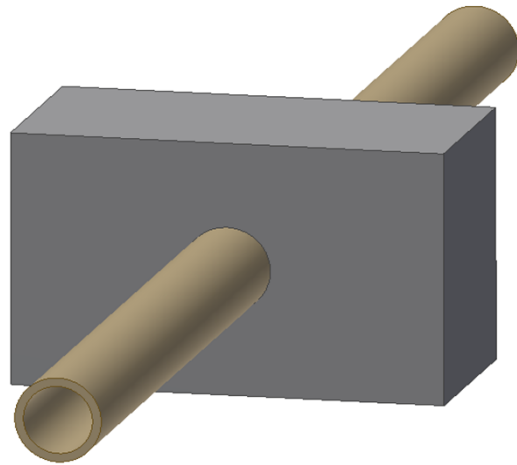
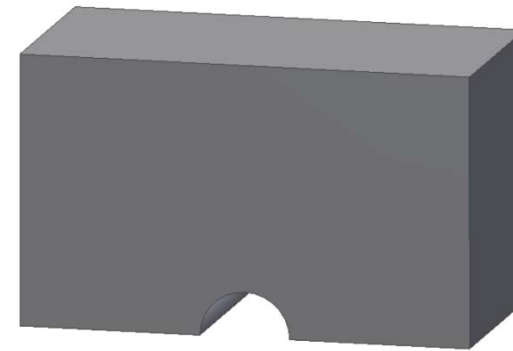
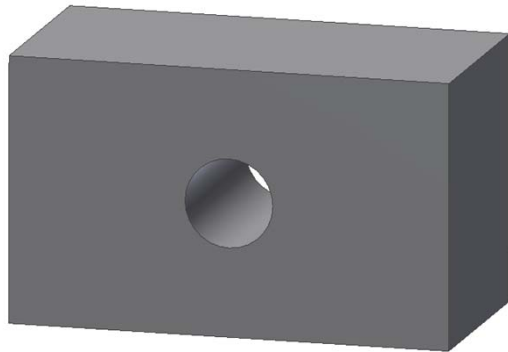

## (2) Engineering and design of a new multiphase PIM tool

# The new multiphase PIM tool developed @ KIT

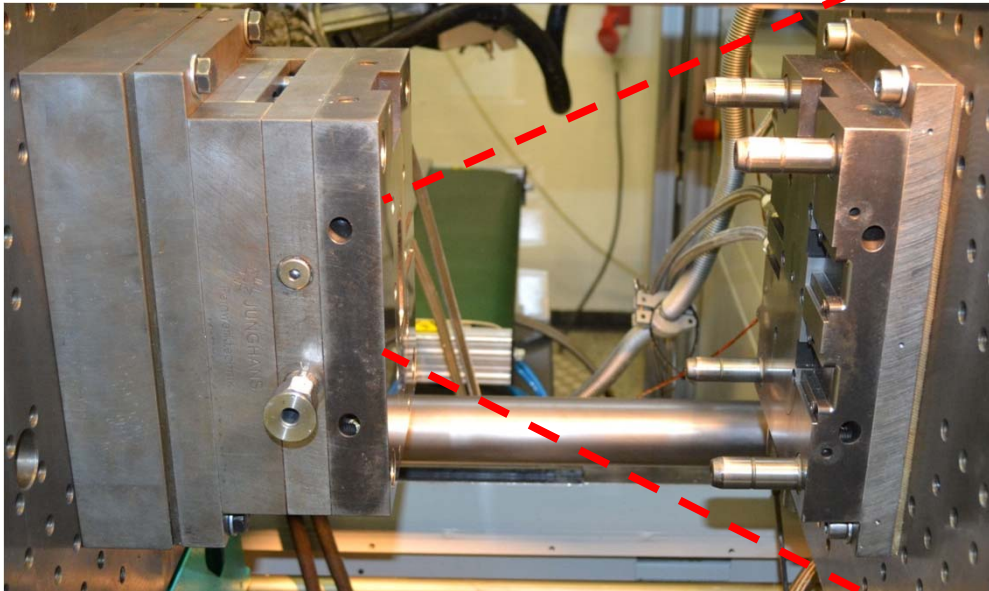

(3) Production of parts with the new tool

(4) Adaption of the heat-treatment process (in close cooperation with PLANSEE SE)



...first parts produced...

### Heat-treatment (only Sintering):

- dry H<sub>2</sub> atmosphere
- 1800°C (2h) + 2400 °C (2h)

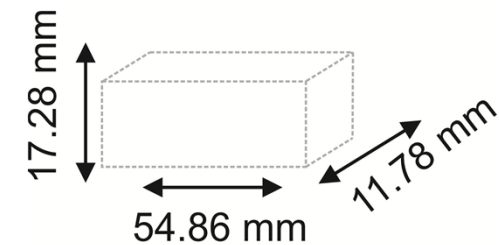

weight: 202 g

# Oulook

## Work Programme 2013

### Goal 2013: Development of a multiphase PIM tool

1. Development of new Designs for HC + WC Divertor (in close Cooperation with CCFE) *in progress*
2. *Engineering and design of a new multiphase PIM tool*
3. Production of parts with the new tool
  1. *First parts produced*
  2. Developing of new designs (joining / interlayer) *in progress*
4. *Adaption of the heat-treatment process (in close cooperation with PLANSEE SE)*
5. Characterization of mechanical and physical properties (in close cooperation with OXFORD Materials)
6. HHF testing (in close cooperation with FZ Jülich and IPP Garching) and characterization after testing



PLANSEE

**Thank you very much!**



PL FUSION