

Gases, in Particular Helium, as Nuclear Reactor Coolant

E. Bubelis

Institute for Neutron Physics and Reactor Technology



Séminaire

**FLUIDES CALOPORTEURS POUR REACTEURS À
NEUTRON RAPIDES**

Contents

- ✓ **Gas-cooled reactors. History**
- ✓ **Current high-temperature reactors**
- ✓ **Gen-IV advanced reactors**
- ✓ **EC financed gas-cooled reactor projects**
- ✓ **Motivation for gas-cooled fast reactors**
- ✓ **Carbon dioxide vs. Helium**
- ✓ **Specific motivations for helium usage**
- ✓ **Gas coolants. Advantages & Disadvantages**
- ✓ **Conclusions**

Gas-cooled reactors. History (1)

- Gases as reactor coolants have been used since the earliest days of nuclear power ▶ 1947, Windscale Piles, UK (atmospheric air cooled, graphite mod., low pres. & temp., open cycle, large pumping power)
- First generation gas-cooled power reactors ▶ 1953, Magnox reactors, UK (CO₂ cooled, pressurized gas, higher temperatures enough for commercial electricity generation, closed cycle)
- Second generation ▶ 1960s onwards, Advanced gas cooled reactors – AGRs (CO₂ cooled, $T^{\text{cool}}_{\text{out}} = 650^{\circ}\text{C}$, good quality superheated steam, high thermal efficiency – 42%)
- Many CO₂-cooled thermal reactors have been built and many are still operating ▶ > 1000 reactor-years of operation experience in UK alone

Gas-cooled reactors. History (2)

Problem with carbon dioxide that became apparent in AGRs:

➤ At AGR temperatures (~600°C), CO₂ dissociates into CO and O₂ under the combined action of heat and radiation (radiolytic dissociation),

➤ The free oxygen oxidizes the graphite and metallic structures,

➤ CO₂ dissociation can be mitigated using methane:



➤ The carbon gets deposited to “repair” the graphite, the CO builds up to a equilibrium concentration to limit further dissociation and water vapour is extracted by the coolant treatment system,

➤ The rate of CO₂ dissociation becomes unacceptable at higher temperatures.

Gas-cooled reactors. History (3)

- **Helium** was adopted for high temperature thermal reactors (HTRs) to avoid the radiolytic dissociation problems associated with carbon dioxide.
- HTRs operated are: Dragon (UK), AVR and THTR-300 (Germany), Peach Bottom and Fort St Vrain (US), HTR-10 (China), HTTR (Japan)
 - ▶ significant amount of operating experience of helium-cooled reactors has been accumulated;
- Outlet temperatures of 750°C to 950°C
 - ▶ allows high-efficiency electricity generation and production of high-quality process heat.

Gas-cooled reactors. History (4)

- All power reactors in use today are “*thermal*” reactors (fission of U-235)
- For nuclear fission to be considered sustainable, the utilization of natural uranium has to be improved considerably ▶ practical improvement (by a factor 60): breeding of Pu from U-238 and burning it in a “fast” reactor
- “*Fast*” reactor cores are compact ▶ require a very effective coolant to transport heat: liquid metal (sodium, etc.) or an alternative gas coolant
- Both carbon dioxide and helium have been proposed as gas-cooled fast reactor (GCFR) coolants
- CO₂ dissociation problem is less of an issue in GCFR because there is no graphite to oxidize, but there are still metallic components in the reactor ...

Current high-temperature reactors (1)

- Commercial-scale **helium-cooled HTR** projects were pursued in **Germany** and the **USA**
- German program ended in the 1990s, but activity continued in the **USA**
- **USA-Russia** collaboration led to the development of gas turbine modular high-temperature reactor (**GT-MHR**) concept: has prismatic fuel element core; uses direct-cycle helium gas turbine
- German reactors had alternative concept: pebble bed reactors
- After the pebble bed reactor development ceased in Germany, the technology was further developed in South Africa (**PBMR**) and in China (**HTR-10** – exp. plant and **HTR-PM** – commercial size plant)



Current high-temperature reactors (2)

- Within Europe, HTR development continued in the form of ANTARES reactor from AREVA:
 - Based upon GT-MHR, indirect-cycle gas turbine using helium-nitrogen mixture as the working coolant, steam turbine makes use of waste heat from gas turbine exhaust

- Japan developed high-temperature test reactor (HTTR) which was constructed and is in operation

- GTHTR-300 concept extends technology to 300MWth plant driving a direct-cycle helium gas turbine

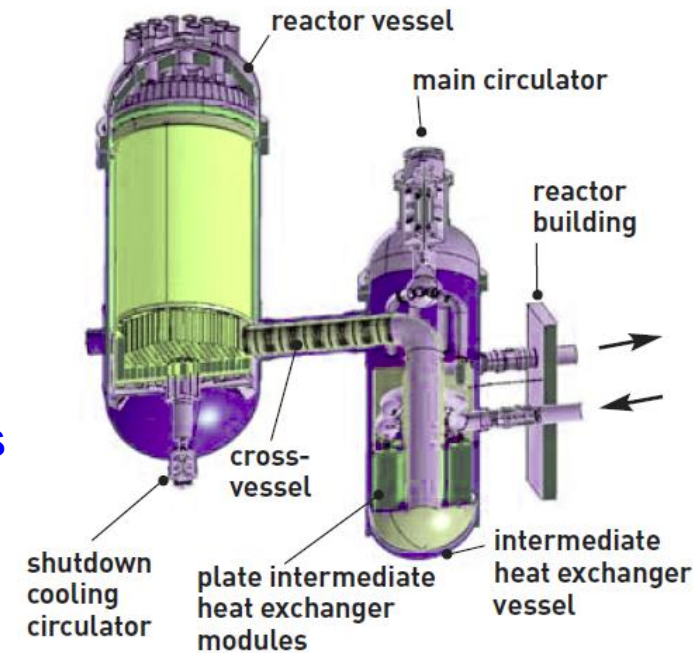

Current high-temperature reactors (3)

- In all above designs the reactor cores are cooled by high-purity **helium**
- **Direct cycle concepts** – the same high-purity helium is used to drive turbine
- **In-direct cycle concepts** – there is freedom to use helium, other gases or gas mixtures, or water/steam

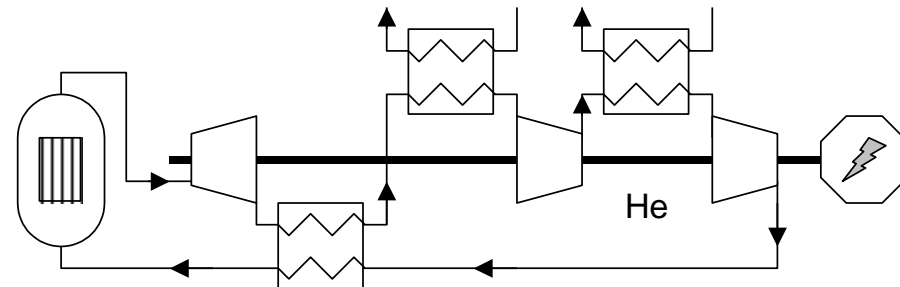

Direct cycle plant problems:

- Need to maintain high-purity helium precludes the use of submerged oil-lubricated bearings in the turbo machinery ▶ use electromagnetic bearings;
- Transport of graphite dust from the core to the turbomachinery, and transport of wear and erosion products from the turbine through the core.
- In-direct cycle plants avoid many of these problems ▶ large int. HXs & circ.

Gen-IV advanced reactors (1)



- **Gen-IV initiative launched by USDOE in the early 2000s**
- **Six systems were proposed for further development – 3 are fast reactors, 3 are thermal or epithermal spectrum reactors**
- **One fast reactor (GFR) and one thermal reactor (VHTR) require helium as the reactor core coolant (primary coolant)**
- **VHTR is an extrapolation from the existing high-temperature reactor technology, aiming at core outlet temperatures of ~ 1000 °C**
- **GFR system aims to capitalize on fast-reactor and high-temperature reactor experience**

VHTR reactor system schematics

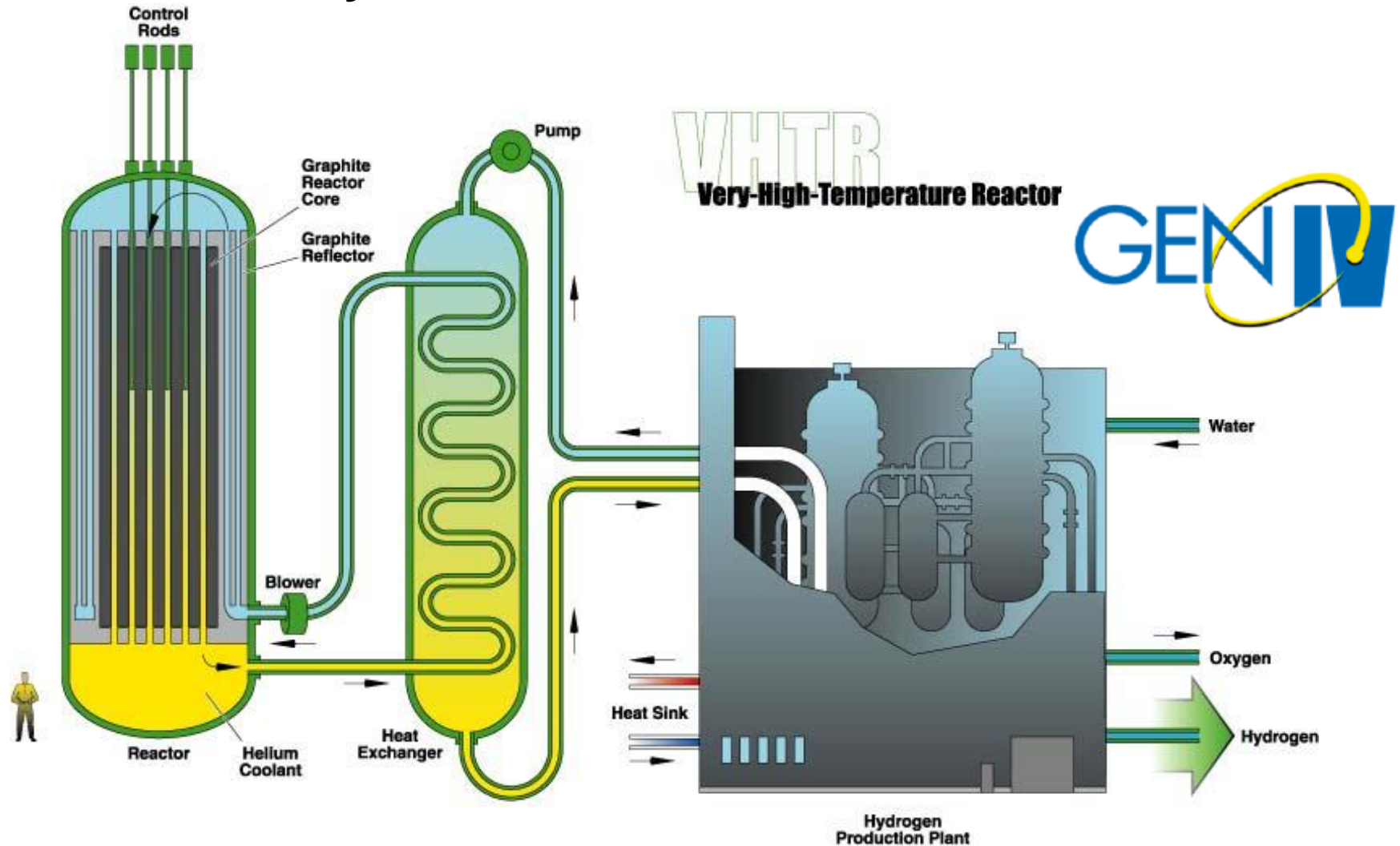

02-GAS0807-01

GFR reactor schematics

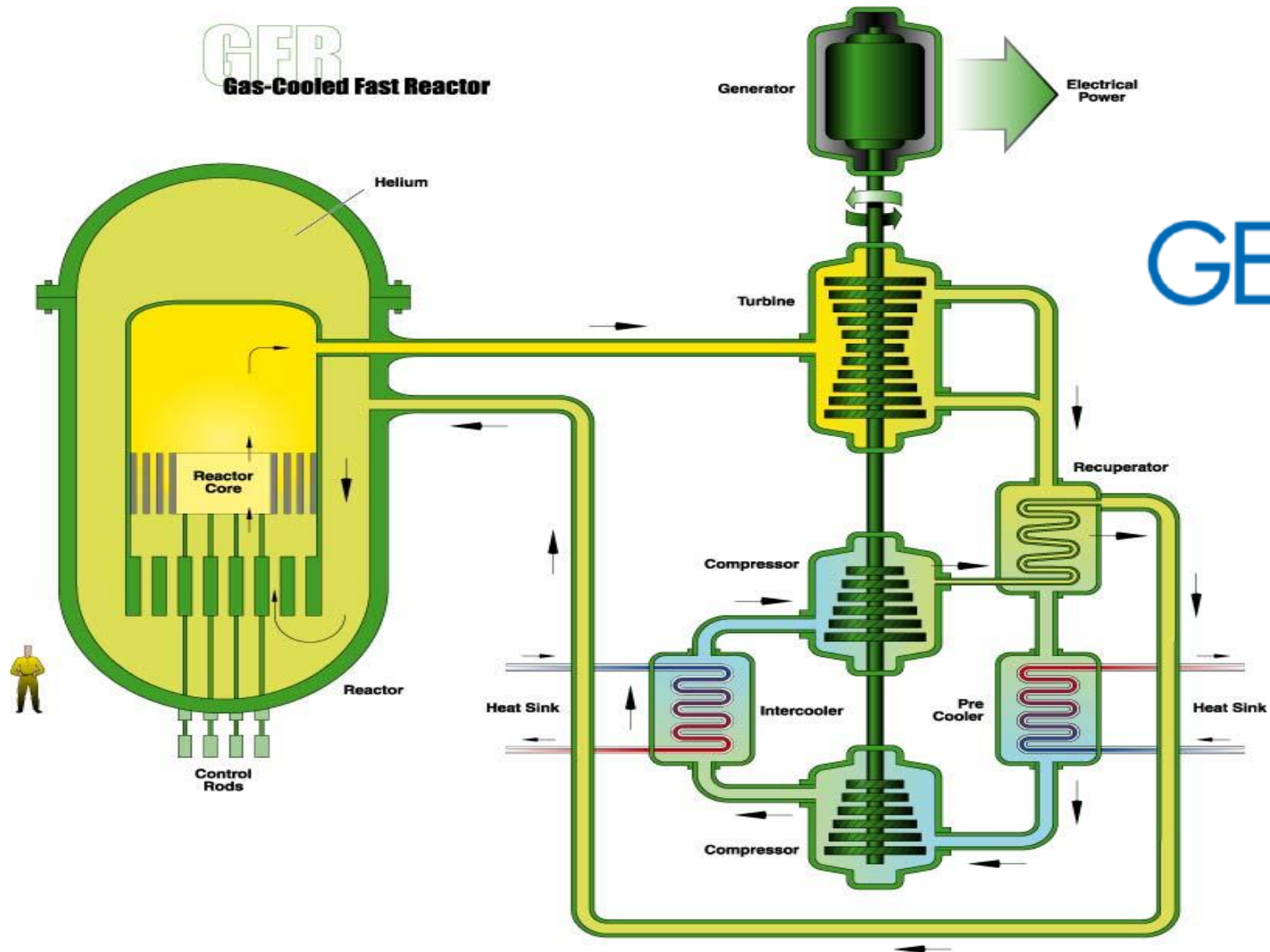

02-GA50807-06

Gen-IV advanced reactors (2)



- Significant advantage of fast reactors in general is their ability to fission the long-lived radionuclides (MA – neptunium, americium & curium)
- GFR is particularly effective owing to the larger proportion of high-energy neutrons present in its neutron spectrum compared with SFR ↔ number of coolant atoms per unit volume is smaller in a gas-cooled core compared with a liquid sodium-cooled core (amount of moderation is smaller)
- Helium offers the best performance in terms of high-temperature chemical stability and a high level of nuclear stability
- Other gases have advantages in terms of higher density, need of lower pumping power and better natural convection performance

Within EU-sponsored Projects (from 2000 to 2013) several different He-cooled GFR concepts were investigated in considerable detail:

FP(5):

1. 80 MWth metallic clad, pin-type, **sub-critical XADS**
60 bar, helium temperatures 200-450 °C

FP(6):

2. 50 MWth metallic clad, pin-type, **critical ETDR**
70 bar, helium temperatures 260-560 °C
3. 2400 MWth ceramic (SiC) clad, plate-type, **critical GFR**
70 bar, helium temperatures 480-850 °C

FP(7):

4. 75 MWth metallic clad, pin-type, **critical ALLEGRO**
70 bar, helium temperatures 260-530 °C
5. 2400 MWth ceramic (SiC) clad, pin-type, **critical GFR**
70 bar, helium temperatures 400-800 °C

75 MWth ALLEGRO reactor

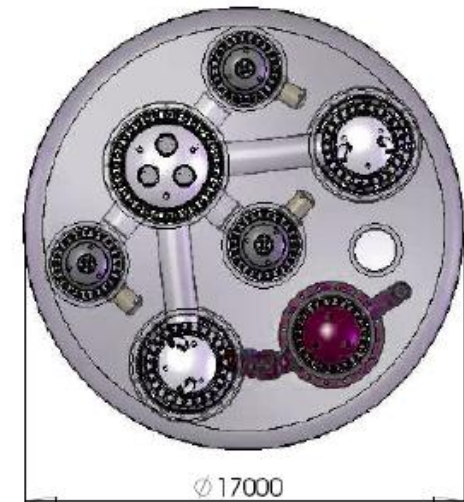
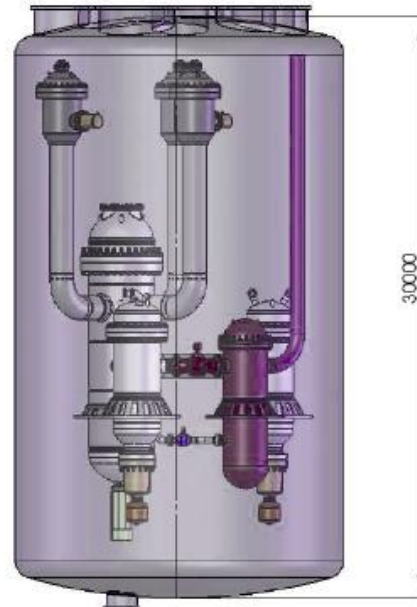
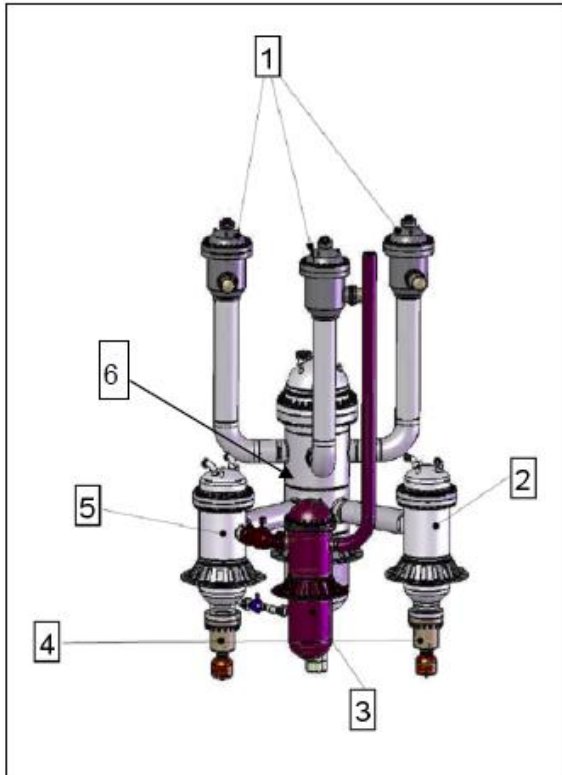

Legend :

- 1- 3x100% DHR Systems in forced or natural convection mode
- 2- IHX 40 MWatt U Tube Helium water
- 3- Optional IHX He/He 10 MWatt
- 4- 2 main blowers with pony motor assist
- 5- Same than 2
- 6- Reactor pressure vessel

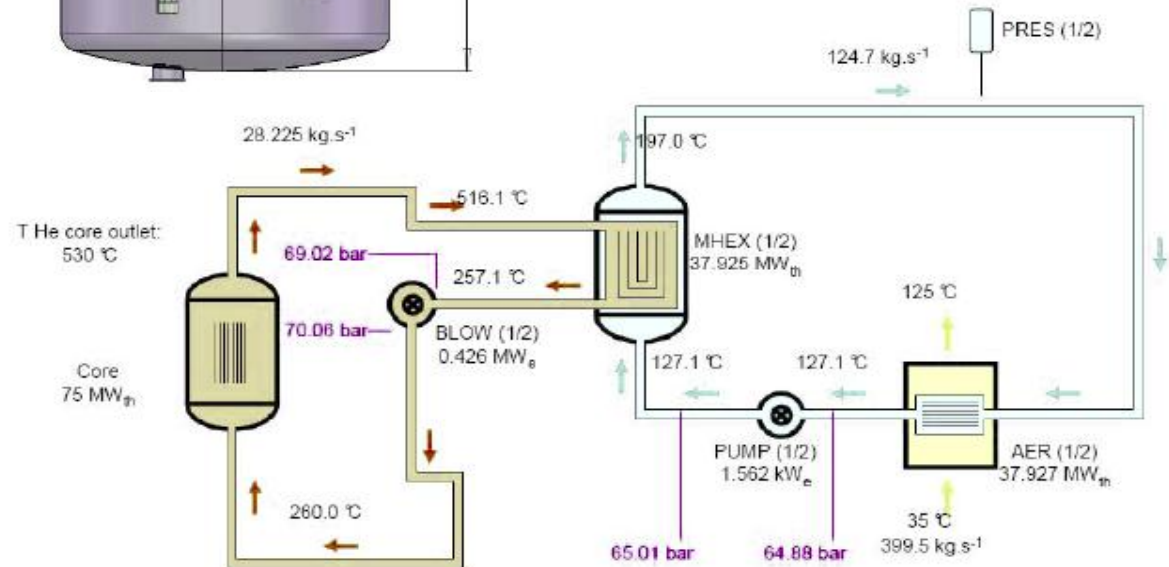

2400 MWth GFR reactor

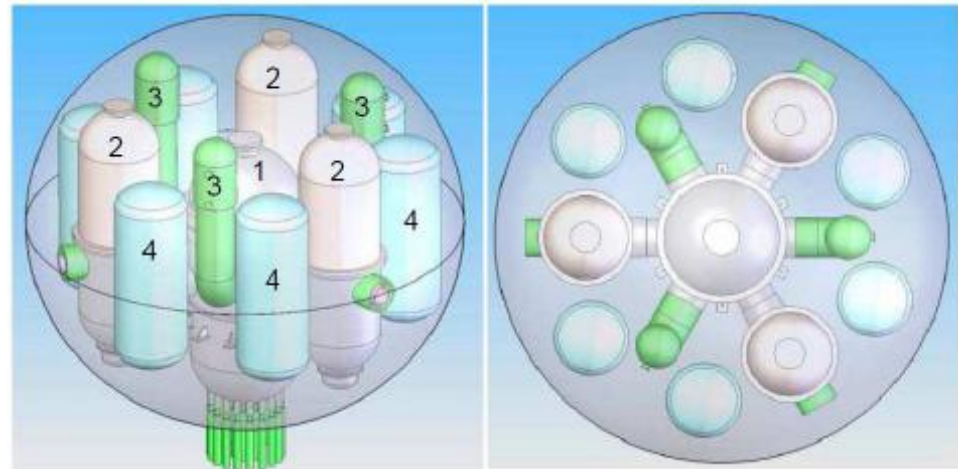
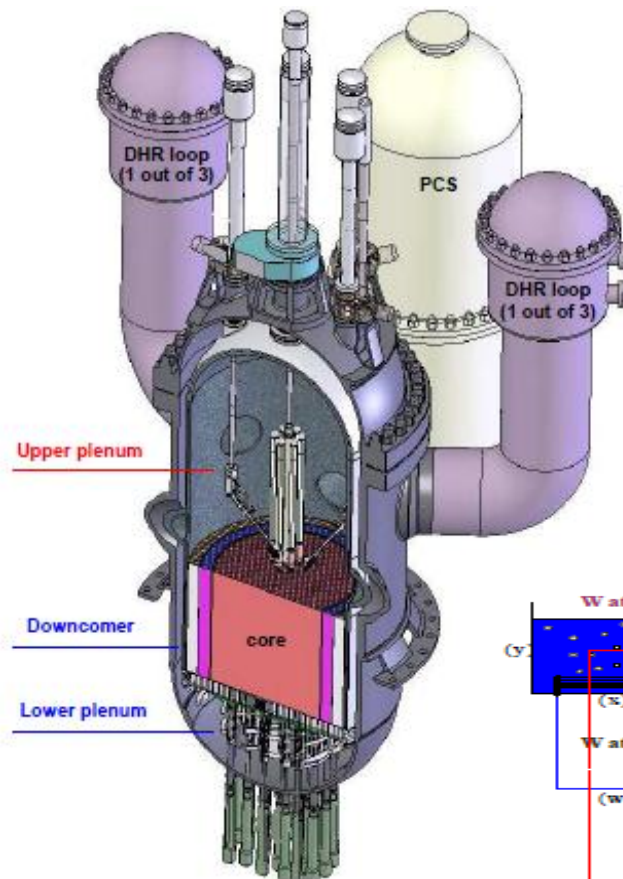

Pressure guard containment with vessel (1), three PCS (2), three DHR loops (3) and six gas reservoirs (4)

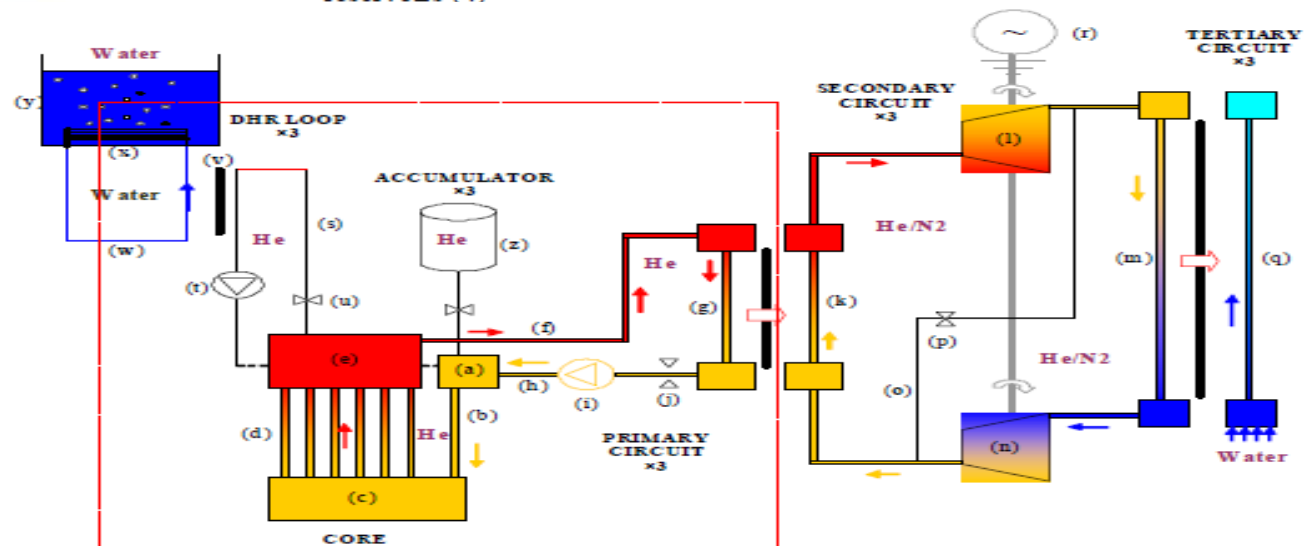

Motivation for gas-cooled fast reactors (1)

Fast reactors are important for the sustainability of nuclear power:

- **More efficient use of fuel,**
- **Reduced volumes and radiotoxicity of high level waste.**

**Sodium cooled fast reactors are the shortest route to FR deployment,
but:**

- **Sodium coolant has some undesirable features: chemical compatibility, positive void coefficient of reactivity, restricted core outlet temperature to avoid sodium boiling, etc.**

Motivation for gas-cooled fast reactors (2)

Gas cooled fast reactors do not suffer from any of the above:

- **Chemically inert, void coefficient is small (but still positive), single phase coolant eliminates boiling,**
- **Allows high temperature operation without the corrosion and coolant radio-toxicity problems associated with heavy liquid metal reactors (LBE or pure Pb), but ...**
- **Gaseous coolants have little thermal inertia ► rapid heat-up of the core following loss of forced circulation, due to the lack of thermal inertia of the core structure & very high power density.**

Motivation is: enhanced safety, low radio-toxicity and improved reactor performance.

Carbon dioxide vs. Helium (1)

Molecular weights: $M \sim 44$ kg/kmol for CO_2 and ~ 4 kg/kmol for He.

- For any working pressure a CO_2 cooled core will require less pumping power than a He cooled core ▶ He gas at high pressure.

$C_{p,\text{CO}_2} = 1.15$ kJ/kg/K and $C_{p,\text{He}} = 5.195$ kJ/kg/K.

- He is a superior gas as regards the thermal conductivity.

Gases: “Poor” heat transfer from surface to coolant.

Solution: change Nu and heat transfer area. Nusselt number is changed by changing the geometry and/or by changing the amount of turbulence (rib roughened pins, metallic clad). The area is changed by changing the geometry or by extending the surfaces (fins).

Carbon dioxide vs. Helium (2)

- Of the two gases, He is chemically inert whereas CO₂ can dissociate.
- Generally, the damaging mechanism with dissociated CO₂ is high temperature oxidation as opposed to traditional “wet” corrosion associated with water-cooled systems.
 - The oxidation rates in CO₂-cooled reactors are generally lower than in water-cooled reactors,
 - Much experience exist in CO₂-cooled thermal reactors on management and limitation of oxidation.

Carbon dioxide vs. Helium (3)

- **Whilst helium is an inert gas, there is still the possibility of chemical attack of the structural materials.**
 - **With most common structural metals, they are protected by a thin, self-repairing, oxide layer that forms naturally in an oxygen containing atmosphere.**
 - **In an inert atmosphere, if the oxide layer is damaged, there is no oxygen available to repair the layer.**
 - **Residual grit content in the primary gas (other gases, steam ...) could lead to chemical interactions with internal components ▶ Needs continuous purification of the gas.**

Carbon dioxide vs. Helium (4)

- In a helium environment, an associated problem is tribology.
 - Surfaces which slide against each other, e.g., bearings, valves and valve seats, and screw threads can effectively weld themselves together (diffusion bonding).
 - This occurs through of the exchange of metal atoms, by diffusion, through the oxide-free surfaces under the action of contact pressure, heat and time.
 - This is a particular problem for safety systems, such as decay heat removal system valves.

Specific motivations for helium usage

	Water	CO2	He	Ar	Na
	150 bar, 300°C	60 bar, 500°C	60 bar, 500°C	60 bar, 500°C	1 bar, 500°C
ρ kg/m ³	725,53	40,86	3,7	37,29	857
Cp J/kg/K	5476	1182	5190	525	1262
λ w/m/K	0,56	0,06	0,303	0,037	66,3
μ 10 ⁻⁵ Pa.s	8,83	3,33	3,73	4,54	24.3
1/Pp (normalized to water)	1	6.10 ⁻⁵	2,8.10 ⁻⁵	5.10 ⁻⁶	0.02
HTC (normalized to water)	1	0.7	0.99	0.65	21.
1/P N.C. (normalized to He)	--	5,5	1	2.8	--

Confirmation of He as a good gas coolant, the main drawback being its low capability regarding natural convection (this explains the discussions about safety systems based on heavy gas injections)

Gas coolants. Advantages



The main safety advantages of gas coolants are:

- ❖ No change in phase of the gas coolant (single phase behaviour);
- ❖ Low reactivity insertion due to voiding of the coolant;
- ❖ Optically transparent (simple in-service inspection of the primary system and internal vessel components) and electrically non-conducting.

Gas coolants. Disadvantages (1)



The main safety disadvantages of gas coolants are:

- ❖ **The low density creating the requirement for pressurization - increases the likelihood and severity of a LOCA.**
- ❖ **Loss of pressure can induce positive reactivity insertions due to voiding, however the effect is relatively small.**
- ❖ **Water/Steam ingress into primary circuit due to HX tube failure can induce significant positive reactivity insertions in addition to chemical attacks.**

Gas coolants. Disadvantages (2)



- ❖ The inability to form a pool, a problem when trying to ensure that the reactor core remains bathed in coolant within a breached primary cooling circuit;
- ❖ Following a severe accident it is easier to manage the core debris if immersed in a pool of liquid coolant, both in terms of cooling and restriction of the release of the fission products into the containment building.

Gas coolants. Disadvantages (3)



- ❖ The non-condensable nature of coolant, if it is lost from the reactor cooling circuit - a problem for pressure loading of the containment.
- ❖ Low thermal inertia means that the reactor core will heat up rapidly if forced cooling or high coolant pressure is lost.
- ❖ The low thermal inertia of the coolant is of particular significance in a fast reactor core.
 - ❖ The core itself possesses little thermal inertia, so the fuel temperatures rise rapidly following a loss of forced circulation of the coolant or the loss of the high coolant pressure.

Gas coolants. Disadvantages (4)



- ❖ The compact core makes the “conduction cool-down” heat path insufficient to remove the decay heat, thus remaining within the fuel temperature limits.
- ❖ Convective cooling is required, either by restoration of forced cooling (through a back-up cooling system or a dedicated forced convection decay heat removal system), or by natural convection (supported by the heavy gas (nitrogen) injection).
- ❖ However, natural convection of gas is not efficient at low pressures due to the low gas density, especially for Helium.

GFR-2400: PLOCA (10 inch break, ~7 bar cont. backup pressure, 2 out of 3 DHRs loops, forced convection)

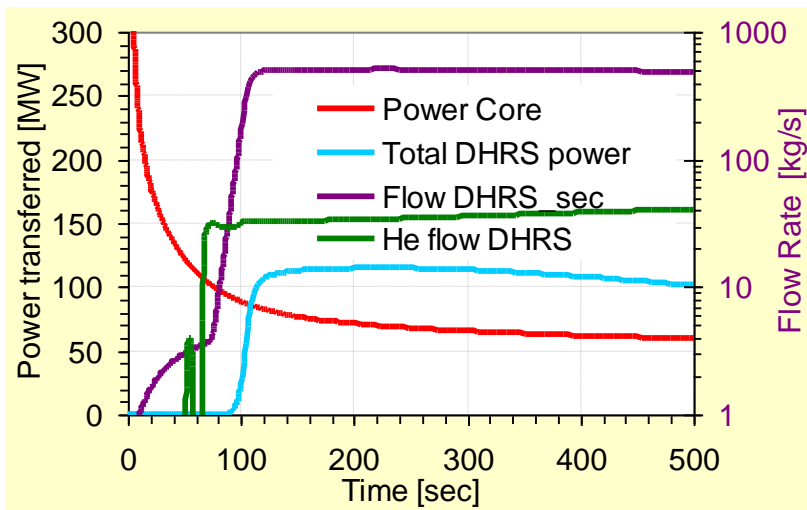
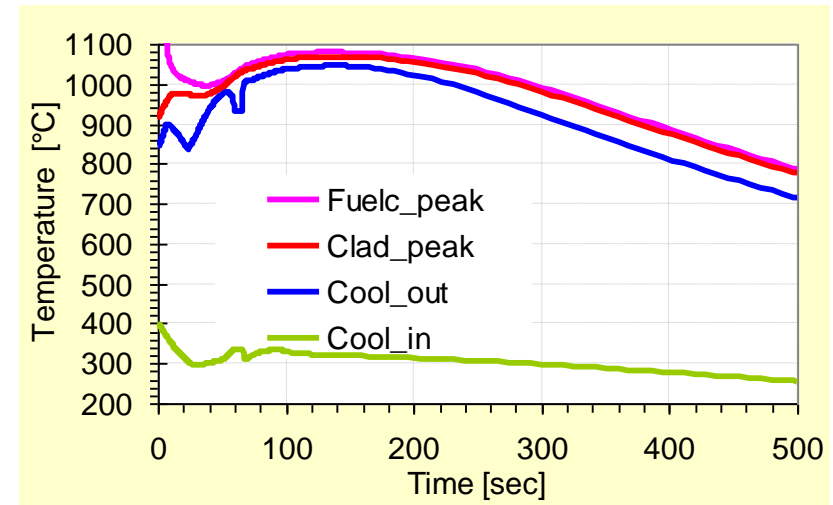
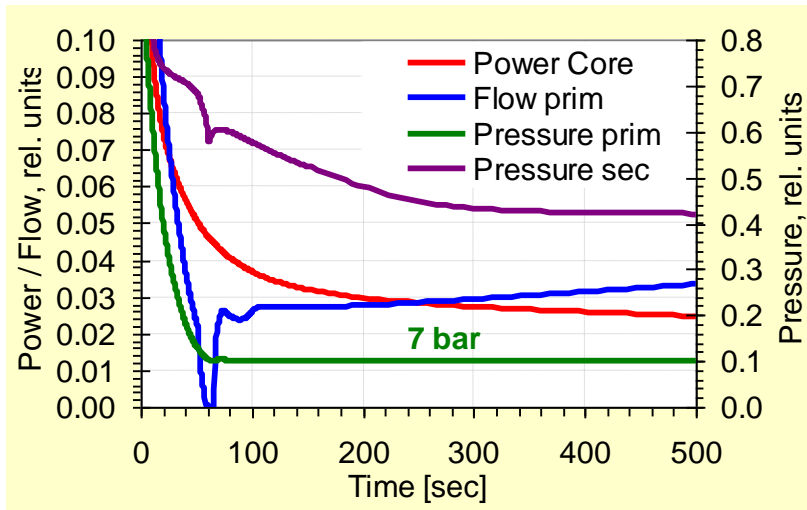

- LB PLOCA transient can be accommodated by GFR reactor without safety concerns, if one uses 2 DHRs loops in forced convection for decay heat removal.

GFR-2400: PLOCA (10 inch break, ~7 bar cont. backup pressure, 2 out of 3 DHRS loops, natural convection)

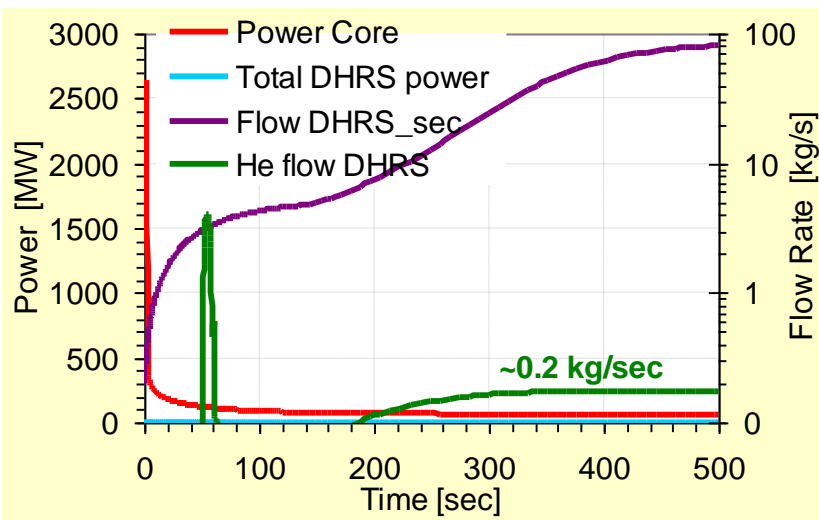
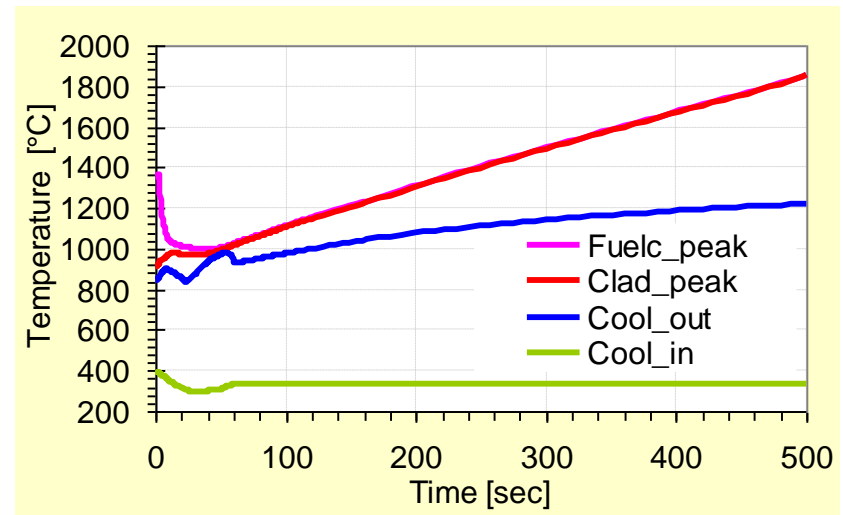
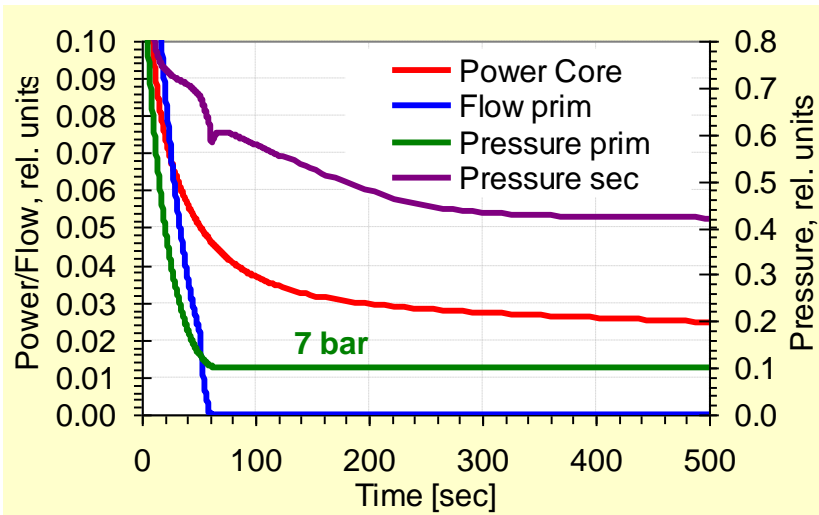

- LB PLOCA transient **cannot be accommodated** by GFR reactor if one uses 2 DHRS loops in natural convection for decay heat removal.
- Peak power pins will lose their leak tightness ($T_{\text{clad}} > 1600^\circ \text{C}$) at $t \sim 6$ min.
- After $t \sim 10$ min mech. & struct. integrity of peak power fuel pins cannot be ascertained ($T_{\text{clad}} \sim 2000^\circ \text{C}$).

Conclusions

- **Gas-cooled** reactors have been deployed on an industrial scale for over half a century, thus accumulating huge operational experience.
- However, most of these reactors are **CO₂**-cooled thermal reactors with moderate operating temperatures.
- **Helium** fits the requirement for high operating temperatures well and is the coolant of choice for high-temperature thermal reactors (HTRs).
- Chemical and nuclear stability of **helium** makes it a good candidate also for gas-cooled fast reactors.
- VHTR and GFR are the two Gen-IV systems in which **helium** has been chosen as the reference gaseous coolant.

References

1. **The future of helium as a natural resource, edited by W. J. Nuttall, R. H. Clarke and B. A. Glowacki, Routledge, London, NY, 2012.**
2. **Basis for the Safety Approach for Design & Assessment of Generation IV Nuclear Systems, Rev. I, prepared by RSWG of Gen-IV IF, OECD NEA, November 2008.**
3. **Á. Horváth and R. Stainsby “ALLEGRO – a Gas-Cooled Fast Reactor Demonstrator. Status of the Project”, GoFastR project presentation, 2012.**
4. **C. Poette “Gas cooled fast reactor. System design”, GoFastR project workshop, Cadarache, 2011.**
5. **M. Schikorr and E. Bubelis “GCFR Thermal-Hydraulic Analysis”, GoFastR project workshop, Cadarache, 2011.**

Additional slides

Helium demands for gas-cooled reactors (1)

The precise helium demands for Gen-IV systems and nearer-term high temperature reactors are not known precisely.

The main factors affecting the helium demand are:

- ❖ Inventory of a single reactor unit,
- ❖ the rate at which new systems are rolled out, and
- ❖ the rate of helium leakage expected.

Helium demands for gas-cooled reactors (2)

Inventory of a single reactor unit

Estimation based on current designs for HTR's:

- ❖ PBMR, 400 MWth, direct cycle gas turbine – helium inventory 4 t.
- ❖ HTR-PM, 250 MWth, indirect steam cycle – helium inventory 2.44 t.

- ❖ ~1 t per 100 MW of thermal power, or ~25 t per GW of electricity, assuming the overall efficiency of ~ 40 %.

- ❖ Only for UK - if all electricity would come from HTRs in the future, we would need 1250 t of Helium to fill them initially.

Helium demands for gas-cooled reactors (3)

The rate at which new systems are rolled out

The rate of roll-out of HTR systems is not certain.

Order of magnitude can be obtained based on UK nuclear industry:

- ❖ UK produces 20% of electricity (10 GW) through nuclear power; if this was to be replaced by HTRs we would need 250 t of helium for the initial charge of the reactors;
- ❖ If all UK's electricity would come from HTRs, the UK would need 1250 t of helium for their initial charge.

As the HTRs are being developed also for non-electricity use, the ultimate helium demand for HTRs should be even greater than stated above.

Helium demands for gas-cooled reactors (4)

The rate of helium leakage

Important also are leakages from gas cooled reactors:

- ❖ The target leakage rate for Dragon reactor is 0.1 % of inventory per day.
- ❖ If we take the Dragon limit of 0.1% of inventory per day – this means the total inventory is replaced every 1000 days (~ 3 years). For a 60 year reactor life, its inventory would be changed 20 times.
- ❖ Hypothetically, satisfying the current UK electricity demand over 60 years could require up to 20000 t of helium (2020 - 2080).
- ❖ Demand for Helium in China: HTR-PM development is proceeding well and deployment is expected to be widespread.