



Forschungszentrum Karlsruhe
Technik und Umwelt

Wissenschaftliche Berichte
FZKA 5877

**State-of-the-Art of
High Power Gyro-Devices
and Free Electron Masers
Update 1996**

M. Thumm
Institut für Technische Physik

Februar 1997

Forschungszentrum Karlsruhe

Technik und Umwelt

Wissenschaftliche Berichte

FZKA 5877

**State-of-the-Art of High Power Gyro-Devices
and Free Electron Masers
Update 1996**

M. Thumm

Institut für Technische Physik

Forschungszentrum Karlsruhe GmbH, Karlsruhe

1997

**Als Manuskript gedruckt
Für diesen Bericht behalten wir uns alle Rechte vor**

**Forschungszentrum Karlsruhe GmbH
Postfach 3640, 76021 Karlsruhe**

ISSN 0947-8620

**STATE-OF-THE-ART OF HIGH POWER GYRO-DEVICES
AND FREE ELECTRON MASERS
UPDATE 1996**

Abstract

Gyrotron oscillators (gyromonotrons) are mainly used as high power millimeter wave sources for electron cyclotron resonance heating (ECRH) and diagnostics of magnetically confined plasmas for generation of energy by controlled thermonuclear fusion. 140 GHz (110 GHz) gyrotrons with output power $P_{\text{out}} = 0.54 \text{ MW}$ (0.53 MW), pulse length $\tau = 3.0 \text{ s}$ (5.0 s) and efficiency $\eta = 40 \%$ (32 %) are commercially available. Total efficiencies around 50 % have been achieved using single-stage depressed collectors. Diagnostic gyrotrons deliver $P_{\text{out}} = 40 \text{ kW}$ with $\tau = 40 \mu\text{s}$ at frequencies up to 650 GHz ($\eta \geq 4 \%$). Recently, gyrotron oscillators have also been successfully used in materials processing. Such technological applications require gyrotrons with the following parameters: $f \geq 24 \text{ GHz}$, $P_{\text{out}} = 10\text{-}50 \text{ kW}$, CW, $\eta \geq 30 \%$. This paper gives an update of the experimental achievements related to the development of high power gyrotron oscillators for long pulse or CW operation and pulsed diagnostic gyrotrons. In addition, this work gives a short overview of the present development of coaxial cavity gyrotrons, gyrotrons for technological applications, relativistic gyrotrons, quasi-optical gyrotrons, cyclotron autoresonance masers (CARMs), gyroklystrons, gyro-TWT amplifiers, gyrotwystron amplifiers, gyro-BWO's, gyro-peniotrons, free electron masers (FEMs) and of vacuum windows for such high-power mm-wave sources. The highest CW powers produced by gyrotron oscillators, gyroklystrons and FEMs are, respectively, 340 kW (28 GHz), 2.5 kW (92 GHz) and 20 W (10 GHz).

**STATUS DER ENTWICKLUNG VON HOCHLEISTUNGS-GYRO-RÖHREN
UND FREI-ELEKTRONEN-MASERN
STAND: ENDE 1996**

Übersicht

Gyrotronoszillatoren (Gyromonotrons) werden vorwiegend als Hochleistungsmillimeterwellenquellen für die Elektron-Zyklotron-Resonanzheizung (ECRH) und Diagnostik von magnetisch eingeschlossenen Plasmen zur Erforschung der Energiegewinnung durch kontrollierte Kernfusion eingesetzt. 140 GHz (110 GHz) Gyrotrons mit einer Ausgangsleistung von $P_{\text{out}} = 0.54 \text{ MW}$ (0.53 MW) bei Pulslängen von $\tau = 3.0 \text{ s}$ (5.0 s) und Wirkungsgraden von $\eta = 40\%$ (32 %) sind kommerziell erhältlich. Durch den Einsatz von Kollektoren mit einstufiger Gegenspannung werden Gesamtwirkungsgrade um 50 % erreicht. Gyrotrons zur Plasmadiagnostik arbeiten bei Frequenzen bis zu 650 GHz bei $P_{\text{out}} = 40 \text{ kW}$ und $\tau = 40 \mu\text{s}$ ($\eta \geq 4 \%$). In jüngster Zeit jedoch finden Gyrotronoszillatoren auch bei der Materialprozeßtechnik erfolgreich Verwendung. Dabei werden Röhren mit folgenden Parametern eingesetzt: $f \geq 24 \text{ GHz}$, $P_{\text{out}} = 10\text{-}50 \text{ kW}$, CW, $\eta \geq 30 \%$. In diesem Beitrag wird auf den aktuellen experimentellen Stand bei der Entwicklung von Hochleistungs-Gyrotronoszillatoren für Langpuls- und Dauerstrichbetrieb sowie von gepulsten Diagnostikgyrotrons eingegangen. Außerdem wird auch kurz über den neuesten Stand der Entwicklung von Gyrotrons mit koaxialem Resonator, Gyrotrons für technologische Anwendungen, relativistischen Gyrotrons, quasi-optischen Gyrotrons, Zyklotron-Autoresonanz-Masern (CARMs), Gyroklystrons, Gyro-TWT-Verstärkern, Gyrotwystron-Verstärker, Gyro-Rückwärtswellenoszillatoren (BWOs), Gyro-Peniotrons, Frei-Elektronen-Maser (FEM) und von Vakuumfenstern für solche Hochleistungsmillimeterwellenquellen berichtet. Die höchsten von Gyrotronoszillatoren, Gyroklystrons und FEMs erzeugten CW-Leistungen sind 340 kW (28 GHz), 2.5 kW (92 GHz) bzw. 20 W (10 GHz).

Contents

1	Introduction	1
2	Classification of Fast-Wave Microwave Sources	2
3	Dispersion Diagrams of Fast Cyclotron Mode Interaction	3
	3.1 Gyrotron oscillator and gyroklystron amplifier	4
	3.2 Cyclotron autoresonance maser (CARM)	6
	3.3 Gyro-TWT (travelling wave tube) and gyrotwystron amplifier	8
	3.4 Gyro-BWO (backward wave oscillator)	9
	3.5 Overview on gyro-devices	10
4	Gyrotron Oscillators for Plasma Heating	11
5	Very High Frequency Gyrotron Oscillators	19
6	Gyrotrons for Technological Applications	22
7	Relativistic Gyrotrons	23
8	Quasi-Optical Gyrotrons	24
9	Cyclotron Autoresonance Masers (CARMs)	25
10	Gyroklystrons, Gyro-TWTs, Gyrotwystrons, Gyro-BWOs and other Gyro-Devices	26
11	Free Electron Masers (FEMs)	30
12	Comparison of Gyrotron and FEM for Nuclear Fusion	32
	Acknowledgments	33
	References	34

1 Introduction

The possible applications of gyrotron oscillators and other cyclotron-resonance maser (CRM) fast-wave devices span a wide range of technologies. The plasma physics community has already taken advantage of recent advances in producing high power micro- and millimeter (mm) waves in the areas of RF plasma heating for magnetic confinement fusion studies, such as lower hybrid heating (1-8 GHz) and electron cyclotron resonance heating (28-160 GHz), plasma production for numerous different processes and plasma diagnostic measurements such as collective Thomson scattering or heat pulse propagation experiments. Other applications which await the development of novel high power sources include deep space and specialized satellite communication, high resolution Doppler radar, radar ranging and imaging in atmospheric and planetary science, drivers for next-generation high-gradient linear accelerators, nonlinear spectroscopy, material processing and plasma chemistry.

Most work on CRM devices has investigated the conventional gyrotron oscillator (gyromonotron) [1-4] in which the wave vector of the radiation in an open-ended, irregular cylindrical waveguide cavity is transverse to the direction of the applied magnetic field, resulting in radiation near the electron cyclotron frequency or at one of its harmonics. Long pulse and CW gyrotron oscillators delivering output powers of 100-900 kW at frequencies between 28 and 160 GHz have been used very successfully in thermonuclear fusion research for plasma ionization and start-up, electron cyclotron resonance heating (ECRH) and local current density profile control by noninductive electron cyclotron current drive (ECCD) at power levels up to 4 MW.

ECRH has become a well-established heating method for both tokamaks [5] and stellarators [6]. The confining magnetic fields in present day fusion devices are in the range of $B_0=1-3.5$ Tesla. As fusion machines become larger and operate at higher magnetic fields ($B \cong 5T$) and higher plasma densities in steady state, it is necessary to develop CW gyrotrons that operate at both higher frequencies and higher mm-wave output powers. The requirements of the projected tokamak experiment ITER (International Thermonuclear Experimental Reactor) and of the future new stellarator (W7-X) at the Division of the Max-Planck-Institut für Plasmaphysik in Greifswald are between 10 and 50 MW at frequencies between 140 GHz and 170 GHz [7]. This suggests that mm-wave gyrotrons that generate output power of at least 1 MW, CW, per unit are required. Since efficient ECRH needs axisymmetric, narrow, pencil-like mm-wave beams with well defined polarization (linear or elliptical), single mode gyrotron emission is necessary in order to generate a TEM_{00} Gaussian beam mode. Single mode 110-170 GHz gyromonotrons with conventional cylindrical cavity, capable of high average power 0.5 - 1 MW per tube, CW, and 2 MW coaxial cavity gyrotrons are currently under development. There has been continuous progress towards higher frequency and power but the main issues are still the long pulse or CW operation and the appropriate mm-wave vacuum window. The availability of sources with fast frequency tunability would permit the use of a simple, non-steerable mirror antenna at the plasma torus for local current drive experiments [8]. Slow frequency tuning has been shown to be possible on quasi-optical Fabry-Perot cavity gyrotrons [9] as well as on cylindrical cavity gyrotrons with step tuning (different working modes) [10, 11].

This work reports on the status and future prospects of the development of gyrotron oscillators for ECRH but also refers to the development of pulsed very high frequency gyromonotrons for active plasma diagnostics [12].

Recently, gyrotron oscillators also are successfully utilized in materials processing (e.g. advanced ceramic sintering, surface hardening or dielectric coating of metals and alloys) as well as in plasma chemistry [13]. The use of gyrotrons for such technological applications appears to be of interest if one can realize a relatively simple, low cost device which is easy in service (such as a magnetron). Gyrotrons with low magnetic field (operated at the 2nd harmonic of the electron cyclotron frequency), low anode voltage, high efficiency and long lifetime are under development. Mitsubishi company in Japan is employing a permanent magnet system. The state-of-the-art in this area is also briefly reviewed here.

The next generation of high-energy physics accelerators and the next frontier in understanding of elementary particles is based on the super collider. For linear electron-positron colliders that will reach center-of-mass energies of about 1 TeV it is thought that sources at 17 to 35 GHz with $P_{\text{out}} = 300$ MW, $\tau = 0.2$ μs and characteristics that will allow approximately 1000 pulses per second will be necessary as drivers [14]. These must be phase-coherent devices, which can be either amplifiers or phase locked oscillators. Such generators are also required for super range high resolution radar and atmospheric sensing [15]. Therefore this report gives an overview of the present development status of relativistic gyrotrons, cyclotron autoresonance masers (CARM), gyrotron travelling wave tube amplifiers (Gyro-TWT), gyroklystrons and gyrotwistrons for such purposes as well as of free electron masers (FEM) and broadband gyrotron backward wave oscillators (Gyro-BWO) for use as drivers for FEM amplifiers.

The present status report updates the experimental achievements in the development of high power gyro-devices and free electron masers reviewed in [7] and in the FZKA Reports 5564 (April 1995) and 5728 (March 1996) with the same title.

2 Classification of fast-wave microwave sources

Fast-wave devices in which the phase velocity v_{ph} of the electromagnetic wave is greater than the speed of light c , generate or amplify coherent electromagnetic radiation by stimulated emission of bremsstrahlung from a beam of relativistic electrons. The electrons radiate because they undergo oscillations transverse to the direction of beam motion by the action of an external force (field). For such waves the electric field is mainly transverse to the propagation direction.

The condition for coherent radiation is that the contribution from the electrons reinforces the original emitted radiation in the oscillator or the incident electromagnetic wave in the amplifier. This condition is satisfied if a bunching mechanism exists to create electron density variations of a size comparable to the wavelength of the imposed electromagnetic wave. To achieve such a mechanism, a resonance condition must be satisfied between the periodic motion of the electrons and the electromagnetic wave in the interaction region [15]

$$\omega - k_z v_z \cong s\Omega \quad , \quad s = 1, 2, \dots \quad (k_z v_z = \text{Doppler term}) \quad (1)$$

here ω and k_z are the electromagnetic wave frequency and characteristic axial wavenumber, respectively, v_z is the translational electron drift velocity, Ω is an effective frequency, which is associated with macroscopic oscillatory motion of the electrons, and s is the harmonic number.

In the electron cyclotron maser (ECM), electromagnetic energy is radiated by relativistic electrons gyrating along an external longitudinal magnetic field. In this case, the effective frequency Ω corresponds to the relativistic electron cyclotron frequency:

$$\Omega_c = \Omega_{co}/\gamma \quad \text{with} \quad \Omega_{co} = eB_0/m_0 \quad \text{and} \quad \gamma = [1 - (v/c)^2]^{-1/2} \quad (2)$$

where e and m_0 are the charge and rest mass of an electron, γ is the relativistic factor, and B_0 is the magnitude of the guide magnetic field. A group of relativistic electrons gyrating in a strong magnetic field will radiate coherently due to bunching caused by the relativistic mass dependence of their gyration frequency. Bunching is achieved because, as an electron loses energy, its relativistic mass decreases and it thus gyrates faster. The consequence is that a small amplitude wave's electric field, while extracting energy from the particles, causes them to become bunched in gyration phase and reinforces the existing wave electric field. The strength of the magnetic field determines the value of the radiation frequency.

In the case of a spatially periodic magnetic or electric field (undulator/wiggler), the transverse oscillation frequency Ω_b (bounce frequency) of the moving charges is proportional to the ratio of the electron beam velocity v_z to the wiggler field spatial period λ_w . Thus,

$$\Omega_b = k_w v_z, \quad k_w = 2\pi/\lambda_w \quad (3)$$

The operating frequency of such devices, an example of which is the FEM [16,17], is determined by the condition that an electron in its rest frame "observes" both the radiation and the periodic external force at the same frequency. If the electron beam is highly relativistic, ($v_{ph} \cong v_z \cong c$) the radiation will have a much shorter wavelength than the external force in the laboratory frame ($\lambda \cong \lambda_w/2\gamma^2$ so that $\omega \cong 2\gamma^2 \Omega_b$). Therefore, FEMs are capable of generating electromagnetic waves of very short wavelength determined by the relativistic Doppler effect. The bunching of the electrons in FEMs is due to the perturbation of the beam electrons by the ponderomotive potential well which is caused by "beating" of the electromagnetic wave with the spatially periodic wiggler field. It is this bunching that enforces the coherence of the emitted radiation.

In the case of the ECMs and FEMs, unlike most conventional microwave sources and lasers, the radiation wavelength is not determined by the characteristic size of the interaction region. Such fast wave devices require no periodically rippled walls or dielectric loading and can instead use a simple hollow-pipe oversized waveguide as a circuit. These devices are capable of producing very high power radiation at cm-, mm-, and submillimeter wavelengths.

3 Dispersion diagrams of fast cyclotron mode interaction

The origin of the ECMs traces back to the late 1950s, when three investigators began to examine theoretically the generation of microwaves by the ECM interaction [1,18]: Richard Twiss in Australia [19], Jürgen Schneider in the U.S [20] and Andrei Gaponov in Russia [21]. In early experiments with devices of this type, there was some debate about the generation mechanism and the relative roles of fast-wave interactions mainly producing azimuthal electron bunching and slow-wave interactions mainly producing axial bunching [1,18]. The predominance of the fast-wave ECM resonance with its azimuthal bunching in producing microwaves was experimentally verified in the mid-1960s in the U.S. [22] (where the term "electron cyclotron maser" was apparently coined) and in Russia [23].

Many configurations can be used to produce coherent radiation based on the electron cyclotron maser instability. The departure point for designs based on a particular concept is the wave-particle interaction. Dispersion diagrams, also called ω - k_z plots or Brillouin diagrams [24,25], show the region of cyclotron interaction (maximum gain of the instability) between an electromagnetic mode and a fast electron cyclotron mode (fundamental or harmonic) as an intersection of the waveguide mode dispersion curve (hyperbola):

$$\omega^2 = k_z^2 c^2 + k_{\perp}^2 c^2 \quad (4)$$

with the beam-wave resonance line (straight) given by eq. (1). In the case of a device with cylindrical resonator the perpendicular wavenumber is given by $k_{\perp} = X_{mn} / R_o$ where X_{mn} is the n^{th} root of the corresponding Bessel function (TM_{mn} modes) or derivative (TE_{mn} modes) and R_o is the waveguide radius. Phase velocity synchronism of the two waves is given in the intersection region. The interaction can result in a device that is either an oscillator or an amplifier. In the following subsections, the different ECM devices are classified according to their dispersion diagrams.

3.1 Gyrotron oscillator and gyrokystron amplifier

Gyrotron oscillators were the first ECMs to undergo major development. Increases in device power were the result of Russian developments from the early 1970s in magnetron injection guns, which produce electron beams with the necessary transverse energy (while minimizing the spread in transverse energies) and in tapered, open-ended waveguide cavities that maximize efficiency by tailoring the electric field distribution in the resonator [1-3].

Gyrotron oscillators and gyrokystrons are devices which usually utilize only weakly relativistic electron beams (<100 kV) with high transverse momentum (pitch angle $\alpha = v_{\perp}/v_z > 1$) [26]. The wavevector of the radiation in the cavity is transverse to the direction of the external magnetic field ($k_{\perp} \gg k_z$, and the Doppler shift is small) resulting according to eqs. (1) and (2) in radiation near the electron cyclotron frequency or at one of its harmonics:

$$\omega \cong s\Omega_c, \quad s = 1, 2, \dots \quad (5)$$

In the case of cylindrical cavity tubes (see Figs. 1 and 2) the operating mode is close to cutoff ($v_{ph} = \omega/k_z \gg c$) and the frequency mismatch $\omega - s\Omega_c$ is small but positive in order to achieve correct phasing, i.e. keeping electron bunches in the retarding phase [24-26]. The Doppler term $k_z v_z$ is of the order of the gain width and is small compared with the radiation frequency. The dispersion diagrams of fundamental and harmonic gyrotrons are illustrated in Figs. 3 and 4, respectively. The velocity of light line is determined by $\omega = ck_z$. For given values of γ and R_o , a mode represented by X_{mn} and oscillating at frequency ω is only excited over a narrow range of B_o . By variation of the magnetic field, a sequence of discrete modes can be excited. The frequency scaling is determined by the value of B_o/γ . Cyclotron harmonic operation reduces the required magnetic field for a given frequency by the factor s . The predicted efficiency for gyrotrons operating at higher harmonics ($s = 2$ and 3) are comparable with those operating at the fundamental frequency [1-3,24]. Modern high-power high-order volume mode gyrotron oscillators for fusion plasma applications employ an internal quasi-optical mode converter with lateral microwave output (Tables II-V and IX).

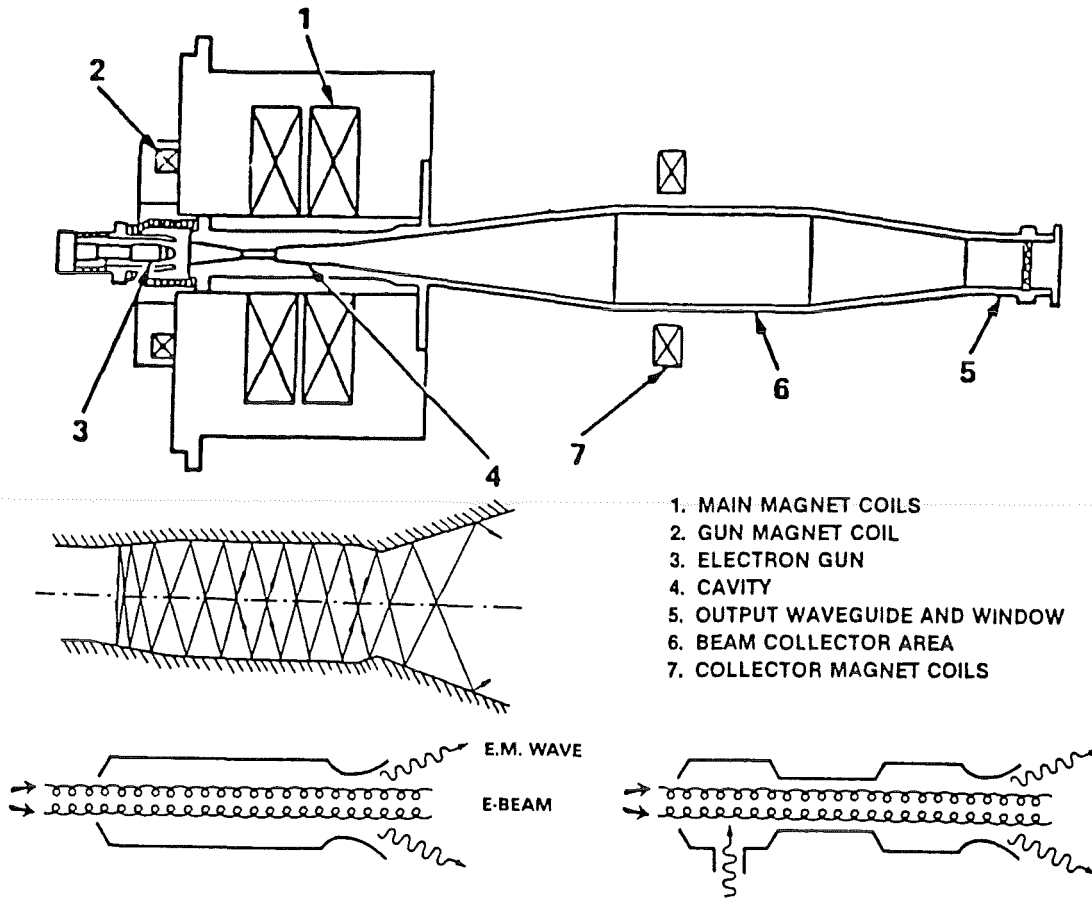

- 1. MAIN MAGNET COILS
- 2. GUN MAGNET COIL
- 3. ELECTRON GUN
- 4. CAVITY
- 5. OUTPUT WAVEGUIDE AND WINDOW
- 6. BEAM COLLECTOR AREA
- 7. COLLECTOR MAGNET COILS

Fig. 1: Schematic of VARIAN CW gyrotron oscillator [4] and scheme of irregular waveguide cavities of gyromonotron oscillator (left) and gyrokylystron amplifier [24].

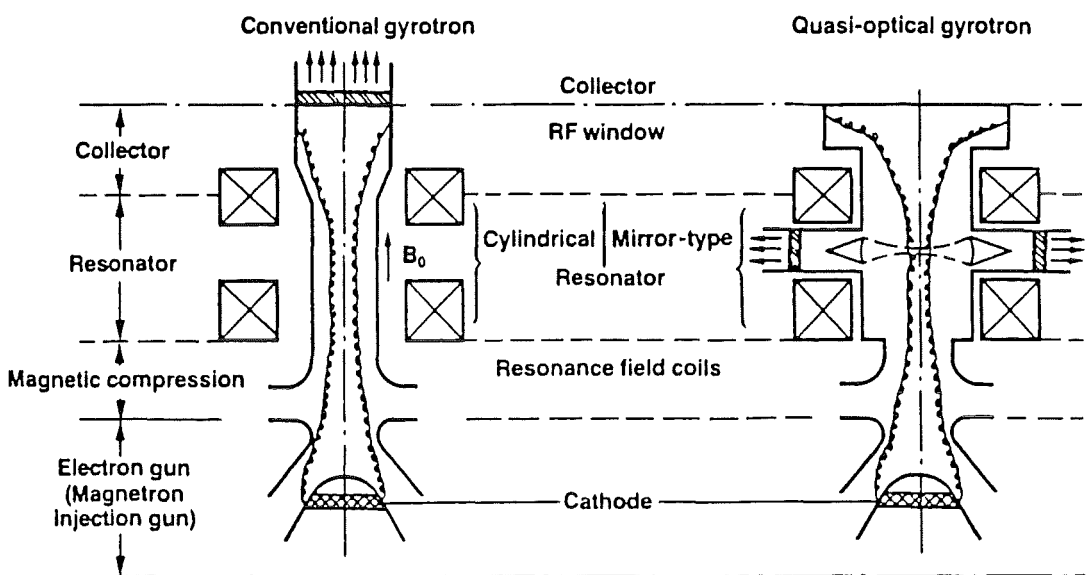

Fig. 2: Principle of a conventional gyrotron with cylindrical resonator and of a quasi-optical gyrotron with mirror resonator [9].

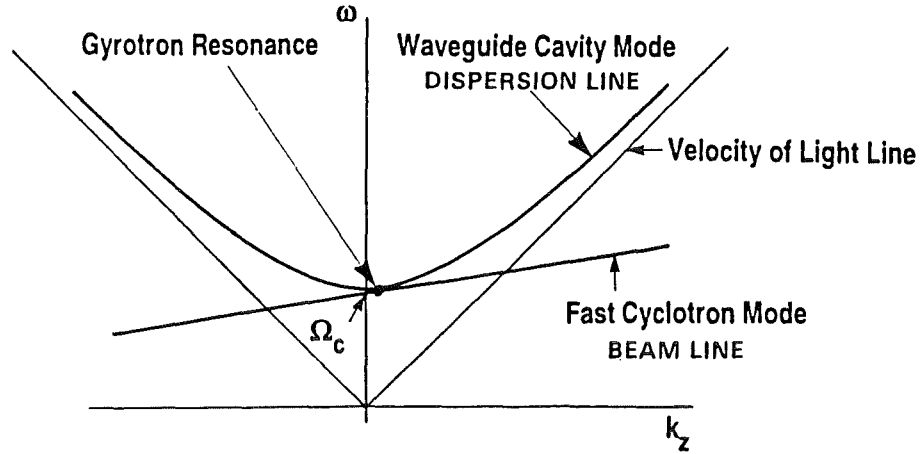

Fig. 3 Dispersion diagram of gyrotron oscillator (fundamental resonance)

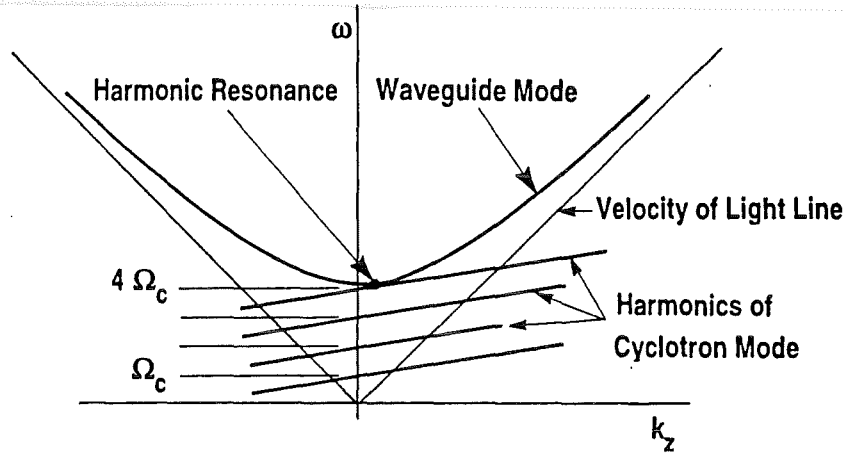

Fig. 4 Dispersion diagram of harmonic frequency gyrotron oscillator

3.2 Cyclotron autoresonance maser (CARM)

In a gyrotron with a highly relativistic beam ($\geq 1\text{MeV}$), an efficient interaction will lead to an average energy loss in the order of the initial electron energy. As a result, the change in the gyrofrequency is much greater than in the mildly relativistic case. It is therefore desirable to identify the condition under which such a highly relativistic electron beam remains in synchronism with the RF field. A possibility for achieving synchronism is to utilize the interaction of electrons with electromagnetic waves propagating with a phase velocity close to the speed of light in the direction of the magnetic field. In this case, the Doppler shift term $k_z v_z$ is large, and the appropriate resonance condition is

$$\omega \cong k_z v_z + s\Omega_c \quad (6)$$

If $v_{ph} \cong c$, the increase in cyclotron frequency due to extraction of beam energy (decrease of γ) nearly compensates the decrease in the Doppler shifted term. Therefore, if the resonance condition is initially fulfilled, it will continue to be satisfied during the interaction. This phenomenon is called autoresonance, and the cyclotron maser devices operating in the relativistic Doppler-shifted regime are called cyclotron autoresonance masers [16]. Fig. 5

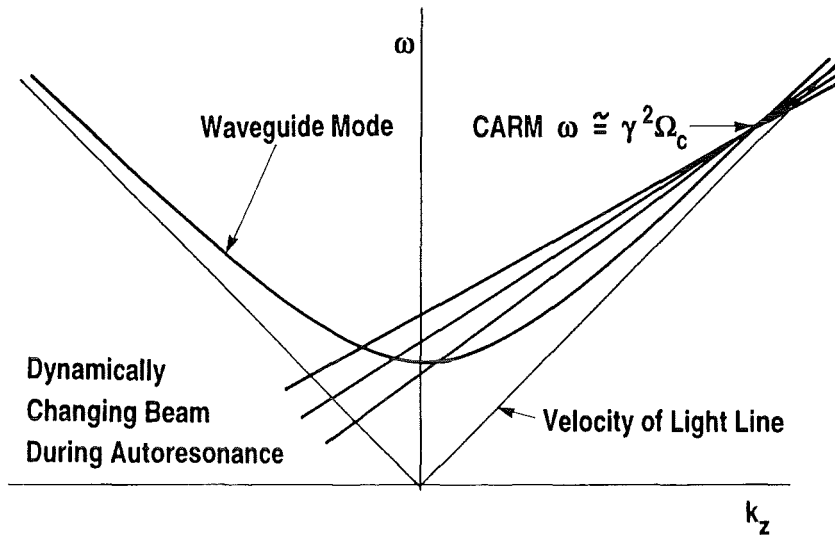

Fig. 5: Dispersion diagram of the cyclotron autoresonance maser (CARM).

shows how the Brillouin diagram of the fast cyclotron wave changes during the autoresonance interaction such that the working frequency ω remains constant even though both Ω_c and v_z are changing. The CARM interaction corresponds to the upper intersection and is based on the same instability mechanism as that of the gyrotron but operated far above cutoff. The instability is convective, so feedback, e.g. by a Bragg resonator (see Fig. 6) [16] is required for an oscillator and it is necessary to carefully discriminate against the other interactions corresponding to the lower frequency intersection in the dispersion diagram Fig. 5. The problem can be alleviated by employing the fundamental TE_{11} or (HE_{11} hybrid mode) and properly choosing system parameters to be within the stability limit. Compared to a gyrotron, there is a large Doppler frequency upshift of the output ($\omega \cong \gamma^2 \Omega_c$) permitting a considerably reduced magnetic field B_0 . Since the axial bunching mechanism can substantially offset the azimuthal bunching the total energy of the beam and not only the transverse component is available for RF conversion.

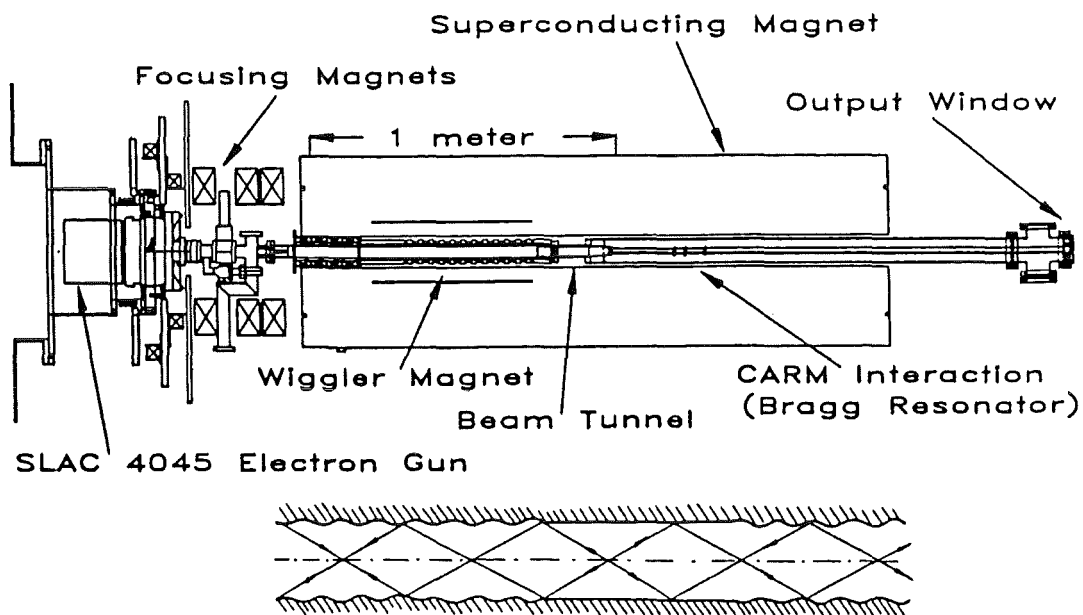

Fig. 6: Schematic of the long-pulse MIT CARM oscillator experiment [27] and scheme of a Bragg resonator [16].

In contrast to the gyrotron the CARM has an electron beam with low to moderate pitch angle ($\alpha < 0.7$). The efficiency of CARMs is extremely sensitive to spread in the parallel beam velocity. The velocity spread $\Delta v_z/v_z$ must be lower than 1% to achieve the full theoretically expected efficiency of 40%. [16,26].

3.3 Gyro-TWT (travelling wave tube) and gyrotwystron amplifier

From the theoretical point of view, the gyro-TWT differs from the CARM only in regimes of operation. The gyro-TWT utilizes a moderately relativistic electron beam to interact with a fast waveguide mode near the grazing intersection of the frequency versus wavenumber plot (see Fig. 7) where the resonance line is tangent to the electromagnetic mode. This produces high gain and efficiency because the phase velocities of the two modes are

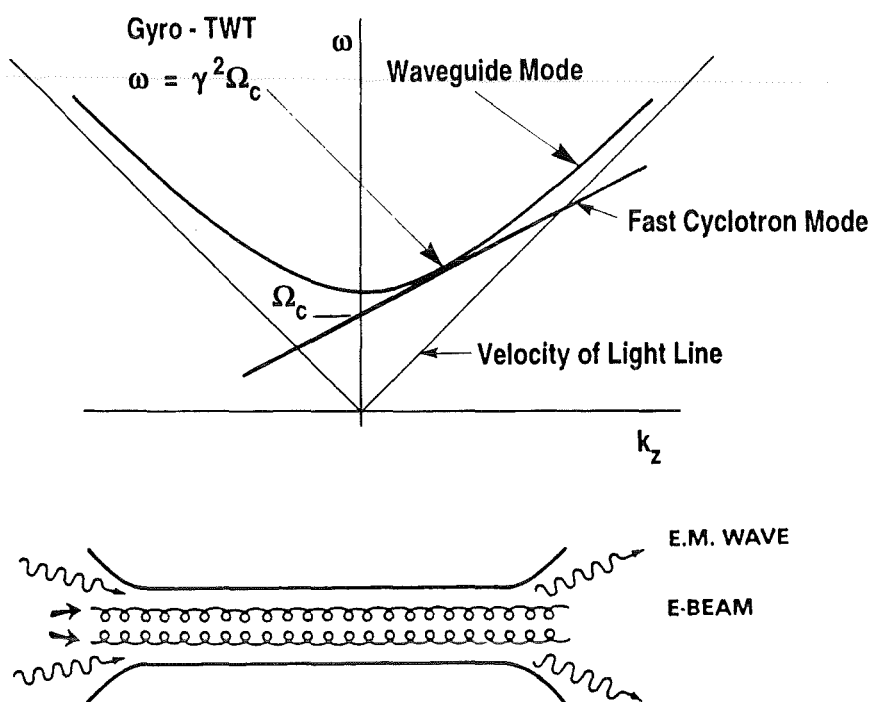

Fig. 7: Dispersion diagram and scheme of interaction circuit of Gyro-TWT amplifier.

nearly matched and the group velocity of the waveguide mode is nearly equal to v_z . In the gyro-TWT regime ($\omega/k_z \gg c$), the axial bunching mechanism is too weak to be of any significance. To benefit from autoresonance, the cutoff frequency should be reduced relative to the cyclotron frequency. The circuit employed in a gyro-TWT consists simply of an unloaded waveguide. Since no resonant structures are present, the gyro-TWT is potentially capable of much larger bandwidth than a gyrokystron and thus can be used as output amplifier in mm-wave radar communication systems. Recent devices employ tapered magnetic field and interaction circuit as well as two stages in order to optimize the beam-wave interaction along the waveguide [28].

The gyrotwystron [1], a hybrid device, is derived from the gyrokystron by extending the length of the drift section and replacing the output cavity with a slightly tapered waveguide section like in a gyro-TWT. The output waveguide section is excited by the beam of electrons that are bunched because of modulation in the input cavity.

3.4 Gyro-BWO (backward wave oscillator)

If the electron beam and/or magnetic field is adjusted so that the straight fast-wave beam line crosses the negative k_z -branch of the waveguide mode hyperbola (see Fig. 8) then an absolute instability (internal feedback) with a "backward wave" occurs. In the gyro-BWO the

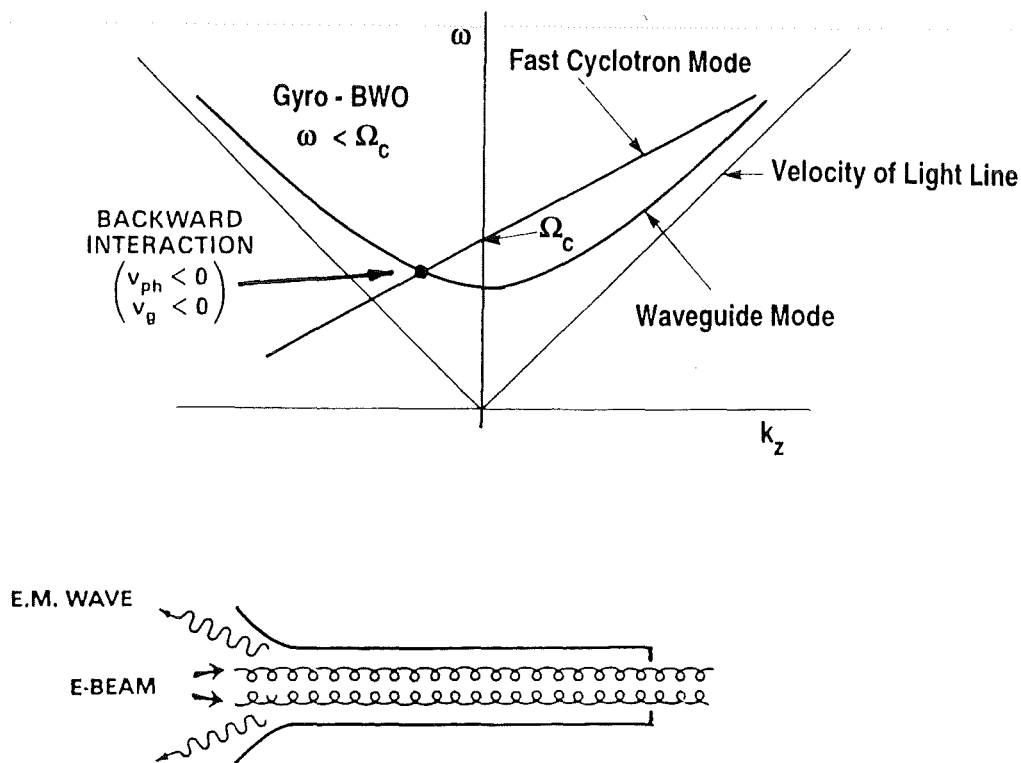

Fig. 8: Dispersion diagram and scheme of interaction circuit of Gyro-BWO.

frequency of operation is now governed by the slope of the line, which is a function of v_z , and thus of the beam acceleration voltage U_{beam} . Consequently, just as in the case of other BWOs (e.g. carcinotron), the frequency of oscillations can be continuously changed very fast over a broad range, using U_{beam} in place of B_0 . However, there is a Doppler down shift in frequency ($\Omega_c/2 < \omega < \Omega_c$), so that very high magnetic fields are required for high frequency operation.

3.5 Overview on gyro-devices

Bunching of electrons in the gyrotron oscillator discussed in section 3.1 has much in common with that in conventional "O-type" electron beam devices, namely, monotron, klystron, TWT, BWO and twystron [1]. In both cases the primary energy modulation of electrons gives rise to bunching (azimuthal or longitudinal) which is inertial. The bunching continues even after the primary modulation field is switched off (at the drift section of a klystron-type devices). This analogy suggests the correspondence between O-type devices and various types of gyro-devices. Table I presents the schematic drawings of devices of both classes and the orbital efficiencies calculated using a uniform approximation for the longitudinal structure of the RF field in the gyromonotron ($s=1$) [1]. For the gyroklystron, the calculation was made in the narrow-gap approximation of the RF field in the input and output cavities. The electrodynamic systems of the gyro-TWT and gyro-BWO, as well as the output section of the gyrotwystron, were assumed to have the form of a uniform waveguide. In all these cases the magnetic field is assumed to be homogeneous.





"O" TYPE DEVICE					
	MONOTRON	KLYSTRON	TWT	TWYSTRON	BWO
TYPE OF GYROTRON					
	GYRO-MONOTRON	GYRO-KLYSTRON	GYRO TWT	GYRO-TWYSTRON	GYRO BWO
MODEL RF FIELD STRUCTURE					
ORBITAL EFFICIENCY	0.42	0.34	0.7	0.6	0.2

Table I: Overview of gyro-devices and comparison with corresponding conventional O-type devices [1].

In Tables XVI, XXIII and XXIV we will briefly consider two other source types similar to, but also fundamentally different in one way or another from, the ECMs. The large orbit gyrotron employs an axis-encircling electron beam in which the trajectory of each electron takes it around the axis of the cylindrical interaction region. Peniotron and gyropeniotron are driven by an interaction that is phased quite differently from the ECM interaction; in practice, the peniotron and ECM mechanisms compete [24-26].

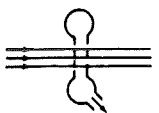
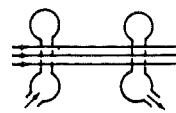
4 Gyrotron oscillators for plasma heating

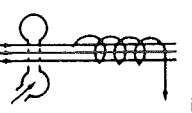
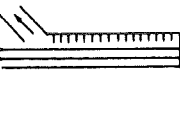
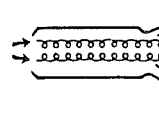
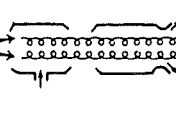
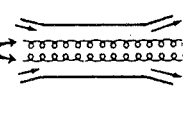
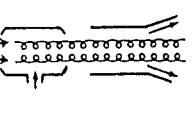
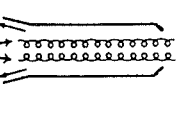
Institution	Frequency [GHz]	Mode cavity	Mode output	Power [MW]	Efficiency [%]	Pulse length [s]
ABB, Baden [29]	8	TE ₀₁	TE ₀₁	0.35	35	0.5
	39	TE ₀₂	TE ₀₂	0.25	42	0.1
HUGHES, Torrance [24]	60	TE ₀₂	TE ₀₂	0.2	35	0.1
IEAS, Beijing [30]	34.3 (2Ω _c)	TE _{02/03}	TE ₀₃	0.2	30	0.02
	36.5 (2Ω _c)	TE ₀₂	TE ₀₂	0.1	25	0.02
MITSUBISHI, Amagasaki [31]	88	TE _{8,2}	TEM ₀₀	0.35	29	0.1
NEC, Kawasaki [32]	35	TE ₀₁	TE ₀₁	0.1	30	0.001
NRL, Washington D.C. [24]	35	TE ₀₁	TE ₀₁	0.15	31	0.02
PHILIPS ¹⁾ , Hamburg [33]	70	TE ₀₂	TE ₀₂	0.14	30	CW
GYCOM (SALUT, IAP) Nizhny Novgorod [11,34-36]	28	TE ₄₂	TEM ₀₀	0.5	40	0.1
	37.5	TE ₆₂	TEM ₀₀	0.5	35	0.2
	53.2	TE ₈₃	TEM ₀₀	0.52	40	0.2
	75	TE ₉₄	TEM ₀₀	0.5	37	0.2
	82.6	TE _{10,4}	TEM ₀₀	0.55	35	2.0
	82.6	TE _{15,4}	TEM ₀₀	0.9 0.5	32 37	0.3 2.0
THOMSON TE, Velizy [37]	8	TE ₅₁	TE ₅₁	1.0	45	1.0
	35	TE ₀₂	TE ₀₂	0.2	43	0.15
TOSHIBA, Ohtawara [38]	28	TE ₀₂	TE ₀₂	0.2	35.7	0.075
	41	TE ₀₂	TE ₀₂	0.2	31.3	0.1
	56	TE ₀₂	TE ₀₂	0.2	32.9	0.1
	70	TE ₀₂	TE ₀₂	0.025	28.4	0.001
CPI ²⁾ , Palo Alto [4,39,40]	8	TE ₂₁	TE ₁₀	0.5	33	1.0
	28	TE ₀₂	TE ₀₂	0.34	37	CW
		0.2			45	CW
	35	TE ₀₂	TE ₀₂	0.2	35	CW
	53.2, 56, 60	TE _{01/02}	TE ₀₂	0.23	37	CW
		70	TE _{01/02}	TE ₀₂	0.21	36
	84	TE _{15,2}	TE _{15,2/4}	0.5 0.89	28 28	0.1 0.001
CPI ²⁾ , NIFS Palo Alto, Nagoya [41]	84	TE _{15,3}	TEM ₀₀	0.5	29	2.0
				0.4	28	10.5
				0.1	14	CW

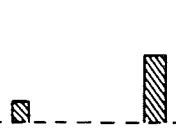
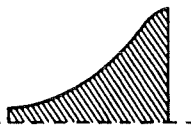
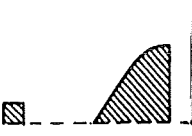
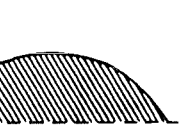
¹⁾ formerly VALVO, ²⁾ Communications & Power Industries, formerly VARIAN

Table II: Performance parameters of gyrotron oscillators for electron cyclotron resonance heating (ECRH) (28-84 GHz) and lower hybrid heating (8 GHz) of plasmas in magnetic confinement fusion studies.

Institution	Frequency [GHz]	Mode cavity	output	Power [MW]	Efficiency [%]	Pulse length [s]	
FZK ¹⁾ , Karlsruhe [43-46]	117.9	TE _{19,5}	TEM ₀₀	1.0	25	0.001	
				1.0	41(SDC)	0.001	
	132.6	TE _{9,4}	TE _{9,4}	0.42	21	0.005	
MITSUBISHI, Amagasaki [47,48]	120	TE _{02/03}	TE ₀₃	0.16	25	0.06	
			TE _{15,2}	TE _{15,2}	1.02	32.5	0.0002
	120	TE _{15,2}		0.46	30	0.1	
				0.25	30	0.21	
GYCOM (SALUT, IAP) Nizhny Novgorod [11,34-36]	106.4	TE _{15,4}	TEM ₀₀	0.5	33	0.5	
	110	TE _{15,4}	TEM ₀₀	0.5	33	0.5	
GYCOM (TORIY, IAP) Moscow, N.Novgorod [35,36,49,87]	110	TE _{19,5}	TEM ₀₀	1.2	40	0.0001	
				1.0	65(SDC)	0.0001	
				0.93	36	2.0	
THOMSON, Velizy [37]	100	TE ₃₄	TE ₃₄	0.19	30	0.07	
			TE ₉₃	TE ₉₃	0.42	17.5	0.002
	110	TE ₆₄	TE ₆₄	0.34	19	0.01	
				0.39	19.5	0.21	
THOMSON, CEA, CRPP, FZK [50-51]	118	TE _{22,6}	TEM ₀₀	0.7	37	0.01	
				0.53	32	5.0	
JAERI, TOSHIBA Naka, Ohtawara [52-56]	110	TE _{22,2}	TEM ₀₀	0.75	27.6	0.002	
				0.61	30	0.05	
				0.61	50(SDC)	0.05	
				0.42	48(SDC)	3.3	
				0.35	48(SDC)	5.0	
	110.1	TE _{22,6}	TE _{22,6}	0.66	31.5	0.001	
	110	TE _{22,12}	TE _{22,12}	0.7	30	0.001	
	120	TE ₀₃	TE ₀₃	0.17	25	0.01	
	120	TE _{12,2}	TE _{12,2}	0.46	24	0.1	
				0.25	24	0.22	
	120	TE _{12,2}	TEM ₀₀	0.5	24	0.1	
	CPI ²⁾ , Palo Alto [4,40,57-60]	106.4 (2Ω _c)	TE _{02/03}	TE ₀₃	0.135	21	0.1
				TE _{12,2}	TE _{12,2}	0.4	30
110		TE _{15,2}	TE _{15,2}	0.5	28	1.0	
				0.3	28	2.0	
				0.5	27	2.5	
110		TE _{22,2}	TE _{22,2/4}	0.5	27	2.5	
110		TE _{22,6}	TEM ₀₀	1.05	32	0.001	
				0.68	31	0.5	
				0.53	30	2.0	
				0.4	28	6.5	
			0.35	27	10.2		
			0.105	21	CW		

SDC: Single-stage Depressed Collector

¹⁾ formerly KfK, ²⁾ Communications & Power Industries, formerly VARIAN

Table IIIa: Present development status of high frequency gyrotron oscillators for ECRH and stability control in magnetic fusion devices ($110 \text{ GHz} \leq f < 140 \text{ GHz}$, $\tau \geq 0.2 \text{ ms}$).

Institution	Frequency [GHz]	Mode cavity output	Power [MW]	Efficiency [%]	Pulse length [s]
FZK ¹⁾ , PHILIPS ²⁾ ,	140.8	TE ₀₃ TE ₀₃	0.12	26	0.4
FZK, Karlsruhe [43-46,61-64]	140.2	TE _{10,4} TE _{10,4}	0.69	28	0.005
	140.2	TE _{10,4} TEM ₀₀	0.60	27	0.012
			0.50	32	0.03
			0.50	48(SDC)	0.03
	140.5	TE _{10,4} TEM ₀₀	0.46	51(SDC)	0.2
	147.4	TE _{11,4} TE _{11,4}	0.35	19	0.005
	154.8	TE _{12,4} TEM ₀₀	0.35	18	0.01
			0.35	27(SDC)	0.005
	140.1	TE _{22,6} TEM ₀₀	1.2	28	0.001
			1.2	45(SDC)	0.001
	162.3	TE _{25,7} TEM ₀₀	1.1	28	0.001
			1.1	49(SDC)	0.001
GYCOM (SALUT, IAP) Nizhny Novgorod [11,34-36,88]	140	TE _{22,6} TEM ₀₀	0.8	32	0.8
			0.8	48(SDC)	0.6
			0.65	49(SDC)	0.6
			0.55	33	2.0
	158.5	TE _{24,7} TEM ₀₀	0.5	30	0.75
	170	TE _{28,7} TEM ₀₀	1.0	32.5	0.0001
GYCOM (TORIY, IAP) Moscow, N.Novgorod [35,36,65-68]	140	TE _{22,6} TEM ₀₀	1.0	36	1.0
			0.96	36	1.2
			0.735	36	1.5
			0.65	36	2.5
			0.55	36	3.0
			0.25	36	5.0
			0.14		9.3
JAERI, TOSHIBA Naka, Ohtawara [69-71]	170	TE _{22,6} TEM ₀₀	0.45	19	0.05
			0.25	19	0.4
			0.25	32(SDC)	0.4
	170.1	TE _{31,8} TE _{31,8}	1.1	30	0.0004
	170.2	TE _{31,8} TEM ₀₀	0.525	19	0.6
			0.525	32(SDC)	0.6
			0.46	38(SDC)	0.05
			0.23		2.2
CPI ³⁾ , Palo Alto [4,40]	140	TE _{02/03} TE ₀₃	0.1	27	CW
	140	TE _{15,2} TE _{15,2}	1.04	38	0.0005
			0.32	30	3.6
			0.26	28	5.0
			0.2 (0.4)	28	avg. (peak)

SDC: Single-stage Depressed Collector

¹⁾ formerly KfK, ²⁾ formerly VALVO, ³⁾ Communications & Power Industries, formerly VARIAN

Table IIIb: Present development status of high frequency gyrotron oscillators for ECRH and stability control in magnetic fusion devices ($f \geq 140$ GHz, $\tau \geq 0.2$ ms).

Institution	Frequency [GHz]	Mode		Power [MW]	Efficiency [%]	Corrug. Cavity	
		cavity	output			inner	outer
FZK ¹⁾ Karlsruhe [74-77] Pulse Length 0.5 ms	137.78	TE _{27,16}	TE _{27,16}	1.03	24.3	yes	no
	139.96	TE _{28,16}	TE _{28,16}	1.17	27.2	yes	no*
	142.02	TE _{29,16}	TE _{29,16}	1.04	24.4	yes	no
	158.93	TE _{32,18}	TE _{32,18}	1.16	26.2	yes	no
	164.98	TE _{31,17}	TE _{31,17}	1.17	26.7	yes	no
	167.14	TE _{32,17}	TE _{32,17}	1.02	26.8	yes	no
IAP, Nizhny Novgorod [3,35,36,78] Pulse Length 0.1 ms	45	TE _{15,1}	TE _{15,1}	1.25	43	no	no
	100	TE _{21,18}	TE _{21,18}	1.0	35	yes	no
				0.5	20	no	no
	100	TE _{25,13}	TE _{25,13}	2.1	30	no	no
				1.6	38	no	no
	103	TE _{22,13}	TE _{22,13}	1.0	40	yes	yes
				0.7	30	yes	no
				0.3	14	no	no
	110	TE _{17,7}	TE _{17,7}	0.7	25	no	no
	110	TE _{20,13}	TE _{20,13}	1.15	35	yes	no
	110	TE _{21,13}	TE _{21,13}	1.0	35	yes	no
140	TE _{28,16}	TE _{28,16}	1.35	28.5	yes	no*	
224(2 Ω_c)	TE _{33,8}	TE _{33,8}	0.1	11	yes	no	
IAP, FZK ¹⁾ Karlsruhe [74] Pulse Length 30 μ s	133	TE _{27,15}	TE _{27,15}	1.3	29	no	no
	140	TE _{28,16}	TE _{28,16}	1.0	23	no	no
MIT, Cambridge [79,80] Pulse Length 3 μ s	137	TE _{25,11}	TEM ₀₀	0.5	7.5	no	no
	139.6	TE _{26,11}	TEM ₀₀	0.9	13	no	no
	142.2	TE _{27,11}	TEM ₀₀	1.0	14.5	no	no
	140	TE _{21,13}	TEM ₀₀	0.5	7.5	no	no

¹⁾ formerly KfK, * very similar cavity and tube design

Table IV: Present experimental development status of short pulse (3-500 μ s) coaxial cavity gyrotron oscillators.

Institution	Frequency [GHz]	Mode cavity output	Power [MW]	Efficiency [%]	Pulse length [s]
FZK ¹⁾ , Karlsruhe [43-46,63,64]	117.9	TE _{19,5} TEM ₀₀	1.0	25	0.001
			1.0	41(SDC)	0.001
	140.2	TE _{10,4} TEM ₀₀	0.60	27	0.012
			0.50	32	0.03
			0.50	48(SDC)	0.03
			0.46	51(SDC)	0.2
	140.5	TE _{10,4} TEM ₀₀	0.46	51(SDC)	0.2
	140.1	TE _{22,6} TEM ₀₀	0.83	24	0.010
			0.83	37(SDC)	0.010
			1.2	28	0.001
	154.8	TE _{12,4} TEM ₀₀	1.2	45(SDC)	0.001
			0.35	18	0.01
			0.35	27(SDC)	0.005
	162.3	TE _{25,7} TEM ₀₀	1.1	28	0.001
1.1			49(SDC)	0.001	
GYCOM (SALUT, IAP) Nizhny Novgorod [87,88]	110	TE _{19,5} TEM ₀₀	1.2	40	0.0001
			1.0	65(SDC)	0.0001
	140	TE _{22,6} TEM ₀₀	0.8	32	0.8
			0.8	48(SDC)	0.6
			0.65	49(SDC)	0.6
NRL, Washington D.C. [89]	115	QOG TEM ₀₀	0.60	9	10 ⁻⁵
			0.43	12.7(SDC)	10 ⁻⁵
			0.20	16.1(SDC)	10 ⁻⁵
JAERI, TOSHIBA Naka, Ohtawara [53-56]	110	TE _{22,2} TEM ₀₀	0.75	27.6	0.002
			0.61	30	0.05
			0.61	50(SDC)	0.05
			0.42	48(SDC)	2.6
			0.35	48(SDC)	5.0
	170	TE _{22,6} TEM ₀₀	0.45	19	0.05
			0.25	19	0.4
			0.25	32(SDC)	0.4
	170.2	TE _{31,8} TEM ₀₀	0.525	19	0.6
			0.525	32(SDC)	0.6
			0.46	38(SDC)	0.05

SDC: Single-stage Depressed Collector;

QOG: Quasi-Optical Gyrotron

¹⁾ formerly KfK

Table V: Present development status of high frequency gyrotron oscillators with single-stage depressed collector (SDC).

Material	Type	Power (kW)	Frequency (GHz)	Pulse Length (s)	Institution
water-free fused silica	single disk inertially cooled	200	60	5.0	UKAEA/Culham
boron nitride	single disk water edge cooled	930	110	2.0	GYCOM (TORIY)
		550	140	3.0	GYCOM (TORIY)
		650	140	2.5	GYCOM (SALUT)
sapphire	single disk LN ₂ edge cooled	530	118	2.0	CEA/CRPP/FZK/THOMSON
		285*	140	3.0	IAP/INFK
		500	140	0.5	FZK/IAP/IPF/IPP
		370	140	1.3	FZK/IAP/IPF/IPP
sapphire	single disk with Cu anchor LHe edge cooled	410	110	1.0	JAERI/TOSHIBA
sapphire	double disk FC75 face cooled	200	60	CW	CPI
		400	84	10.5	NIFS/CPI
		350	110	10.0	CPI
		350	110	5.0	JAERI/TOSHIBA
		200	140	CW	CPI
		500	170	0.6	JAERI/TOSHIBA
sapphire	distributed water cooled	65**	110	0.3	GA/JAERI
		200*	110	0.7	GA/CPI
diamond	single-disk water edge cooled	300**	110	1	CPI/FOM

Note: * and ** indicates that the power corresponds to that of a 1 MW (*) and 0.8 MW (**) HE₁₁ mode, respectively.

Tab. VI: Experimental parameters of high-power millimeter-wave vacuum windows [51, 90-102].

	140 GHz	170 GHz	220 GHz
Gaussian Profile (G)	0.5 MW	0.4 MW	0.3 MW
Flattened Profile (F)	0.7 MW	0.6 MW	0.45 MW
Annular Profile (A)	1.0 MW	0.85 MW	0.65 MW

Table VII: Maximum power transmittance of a single disk, LN₂ edge-cooled sapphire window with resonant thickness ($5\lambda/2$ at 140 GHz, $6\lambda/2$ at 170 GHz, $8\lambda/2$ at 220 GHz) for different power distributions.

	Material	Type	RF-Profile	Cross-Section	Cooling
①	Sapphire/Metal	distributed	flattened Gaussian	rectangular (100 mm x 100 mm)	internally water cooled (300 K) $\tan\delta = 2.5 \cdot 10^{-4}$, $k = 40$ W/mK
②	Diamond	single-disk	Gaussian	circular ($\varnothing = 80$ mm)	water edge cooled (300 K) $\tan\delta = 2 \cdot 10^{-5}$, $k = 1900$ W/mK
③	Diamond	single-disk Brewster	Gaussian	elliptical (152 mm x 63.5 mm)	water edge cooled (300 K) $\tan\delta = 2 \cdot 10^{-5}$, $k = 1900$ W/mK
④	Silicon Au-doped	single-disk	Gaussian	circular ($\varnothing = 80$ mm)	edge cooled (260 K), refrigerator $\tan\delta = 2.5 \cdot 10^{-6}$, $k = 200$ W/mK
⑤	Silicon Au-doped	single-disk	Gaussian	circular ($\varnothing = 80$ mm)	LN ₂ edge cooled (77 K) $\tan\delta = 4 \cdot 10^{-6}$, $k = 1500$ W/mK
⑥	Sapphire	single disk	flattened Gaussian	elliptical (285 mm x 35 mm)	LN ₂ edge cooled (77 K) $\tan\delta = 6.7 \cdot 10^{-6}$, $k = 1000$ W/mK
⑦	Sapphire	single disk	Gaussian	circular ($\varnothing = 80$ mm)	LNe or LHe edge cooled (27 K) $\tan\delta = 1.9 \cdot 10^{-6}$, $k = 2000$ W/mK

Note that the power capability of options ②,③,⑤ and ⑦ is even 2 MW.

Table VIII: Options for 1 MW, CW, 170 GHz gyrotron windows.

Institution	Frequency [GHz]	Mode cavity output	Power [MW]	Efficiency [%]	Pulse length [s]	
FZK, Karlsruhe	117.9	TE _{19,5}	TEM ₀₀	1.0	26	0.0005
				1.0	41(SDC)	0.0005
	121.6	TE _{20,5}	TEM ₀₀	1.0	26	0.0005
	125.3	TE _{21,5}	TEM ₀₀	1.0	26	0.0005
	128.9	TE _{22,5}	TEM ₀₀	0.9	23	0.0005
	132.6	TE _{20,6}	TEM ₀₀	0.85	22	0.0005
	136.2	TE _{21,6}	TEM ₀₀	0.9	23	0.0005
	140.1	TE _{22,6}	TEM ₀₀	1.0	26	0.0005
				1.0	43(SDC)	0.0005
	143.7	TE _{23,6}	TEM ₀₀	1.0	26	0.0005
	147.4	TE _{24,6}	TEM ₀₀	1.1	29	0.0005
	151.2	TE _{25,6}	TEM ₀₀	1.05	27	0.0005
	154.9	TE _{23,7}	TEM ₀₀	0.95	25	0.0005
	158.5	TE _{24,7}	TEM ₀₀	1.1	29	0.0005
	162.3	TE _{25,7}	TEM ₀₀	1.0	26	0.0005
				1.0	46(SDC)	0.0005
	166.0	TE _{26,7}	TEM ₀₀	1.0	25	0.0005

SDC: Single-stage Depressed Collector

¹⁾ formerly KfK

Table IX: Step-tunable conventional cavity 1 MW gyrotron with broadband Brewster window at FZK ($U_c = 83$ kV, $I_b = 47$ A).

5 Very high frequency gyrotron oscillators

Institution	Frequency [GHz]	Mode	Power [kW]	Efficiency [%]	Pulse length [ms]
IAP, N.Novgorod [12,107]	157	TE ₀₃	2.4	9.5	CW
	250	TE ₀₂	4.3	18	CW
	250	TE ₆₅	1	5	CW
	326	TE ₂₃	1.5	6.2	CW
MIT, Cambridge [106,114]	209	TE ₉₂	15	3.5	0.001
	241	TE _{11,2}	25	6.5	0.001
	302	TE ₃₄	4	1.5	0.0015
	339	TE _{10,2}	4	3	0.0015
	363	TE _{11,2}	7	2.5	0.0015
	417	TE _{10,3}	15	6	0.0015
	457	TE _{15,2}	7	2	0.0015
	467	TE _{12,3}	22	3.5	0.0015
	503	TE _{17,2}	10	5.5	0.0015
UNIVERSITY, Fukui [108-111]	383	TE ₂₆	3	3.7	1
	402	TE ₅₅	2	3	1
	576	TE ₂₆	1	2.5	0.5

Table X: Capabilities and performance parameters of mm- and submillimeter-wave gyrotrons operating at the second harmonic of the electron cyclotron frequency, with output power ≥ 1 kW.

Institution	Frequency [GHz]	Mode	Power [MW]	Efficiency [%]	Pulse length [μ s]
MIT, Cambridge [10,80,105,106]	113.2	TE _{23,6}	0.84	25	3
	113.2	TE _{23,6} /TEM ₀₀	0.84	17	3
	140	TE _{15,2}	1.33	40	3
	148	TE _{16,2}	1.3	39	3
	166.6	TE _{27,8}	1.50	34	3
	170.0	TE _{28,8}	1.50	35	3
	173.4	TE _{29,8}	0.72	29	3
	188	TE _{18,3}	0.6		3
	225	TE _{23,3}	0.37		3
	231	TE _{38,5}	1.2	20	3
	236	TE _{21,4}	0.4		3
	287	TE _{28,4}	0.2		3
	280	TE _{25,13}	0.78	17	3
	267	TE _{22,5}	0.537	19	3
320	TE _{29,5}	0.4	20	3	
327	TE _{27,6}	0.375	13	3	
IAP, Nizhny Novgorod [12]	250	TE _{20,2}	0.3	31	30 - 80
	350		0.13	17	30 - 80
	430		0.08	10	30 - 80
	500	TE _{28,3}	0.1	8.2	30 - 80
	540		0.06	6	30 - 80
	600	TE _{38,2}	0.05	5	30 - 80
	650		0.04	4	40
UNIVERSITY, Fukui [109]	278	TE ₃₃	0.001	5	1000
	290	TE ₆₂	0.001	4	1000
	314	TE ₄₃	0.001	4	1000

Table XI: Capabilities and performance parameters of pulsed millimeter- and submillimeter-wave gyrotron oscillators operating at the fundamental electron cyclotron resonance.

Institution	Frequency [GHz]	Mode	Voltage [kV]	Current [A]	Power [MW]	Efficiency [%]	
MIT, Cambridge [72]	187.7	TE _{32,4}	94	57	0.65	12	
	201.6	TE _{35,4}	97	54	0.92	18	
	209.5	TE _{33,5}	98	37	0.54	15	
	213.9	TE _{34,5}	95	51	0.89	18	
	218.4	TE _{35,5}	90	44	0.56	14	
	224.3	TE _{33,6}	91	60	0.90	17	
	228.8	TE _{34,6}	92	59	0.97	18	
				100	59	1.2	20
	265.7	TE _{39,7}	90	57	0.64	12	
	283.7	TE _{43,7}	92	35	0.33	10	
	291.6	TE _{41,8}	93	54	0.887	18	

Table XII: Step tuning of MIT gyrotron oscillator (with large MIG [72]) operating at the fundamental electron cyclotron resonance (pulse length 1.5 μ s).

Institution	Frequency [GHz]	Mode	Voltage [kV]	Current [A]	Power [MW]	Efficiency [%]
MIT, Cambridge [72]	249.6	TE _{24,11}	71	41	0.39	14
	257.5	TE _{23,12}	87	41	0.33	9
	267.5	TE _{25,12}	85	33	0.35	12
	277.2	TE _{27,12}	78	42	0.45	14
	280.1	TE _{25,13}	92	51	0.78	17
	285.2	TE _{26,13}	93	41	0.42	11
	282.8	TE _{23,14}	94	39	0.54	15
	287.9	TE _{24,14}	94	51	0.66	14
	292.9	TE _{25,14}	95	41	0.72	18
	302.7	TE _{27,14}	96	43	0.27	7

Table XIII: Step tuning of MIT gyrotron oscillator (with small MIG [72]) operating at the fundamental electron cyclotron resonance (pulse length 1.5 μ s).

6 Gyrotrons for technological applications

Institution	Frequency [GHz]	Mode cavity	Mode output	Power [kW]	Efficiency [%]	Voltage [kV]	Magnet
IAP, SALUT,	15	TE ₀₁	TE ₀₁	4	50	15	roomtemp.
Nizhny Novgorod,	30 (2 Ω_c)	TE ₀₂	TE ₀₂	10	25	20	roomtemp.
TORIY, Moscow	31.8-34.8	TE ₁₁	TE ₁₁	1.2	40	12	mech.tun.
[11,13,35,36,65,66,116]	35.5-37.5	TE ₀₁	TE ₀₁	0.5	15.3	16	mech.tun.
	35.15	TE ₀₂	TE ₀₂	9.7	43	25	cryo.mag.
	37.5	TE ₆₂	TEM ₀₀	20	35	30	cryo.mag.
	83	TE _{11,3}	TEM ₀₀	20	30	30	cryo.mag.
	150	TE ₀₃	TE ₀₃	22	30	40	cryo.mag.
	160 (2 Ω_c)	TE ₀₃	TE ₀₃	2.4	9.5	18	cryo.mag.
MITSUBISHI, Amagasaki [118-120]	28 (2 Ω_c)	TE ₀₂	TE ₀₂	10	38.7	21	perm.mag. tapered
CPI ¹⁾ , Palo Alto [4]	28	TE ₀₂	TE ₀₂	15	40	40	roomtemp.
	28 (2 Ω_c)	TE ₀₂	TE ₀₂	10.8	33.6	30	roomtemp.
CPI, NIFS Palo Alto, Nagoya [41]	84	TE _{15,3}	TEM ₀₀	50	14	80	cryo.mag.

1) Communications & Power Industries, formerly VARIAN

Table XIV: Performance parameters of present CW gyrotron oscillators for technological applications.

7 Relativistic gyrotrons

Institution	Frequency [GHz]	Mode	Voltage [MV]	Current [kA]	Power [MW]	Efficiency [%]	
IAP, Nizhny Novgorod [127]	20	TM ₀₁	0.5	0.7	40	11.4	
	79-107	TM _{1n}	0.5	2-6.5	30	3-1	slotted echelette cavity, n = 3-10
IAP, Nizhny Novgorod Lebedev/General Phys. Inst. Moscow [124-127]	10	TE ₁₃	0.3	0.4	25	20	slotted cavity
	10	TE ₁₃	0.3	1.0	60	15	slotted cavity with plasma
	40	TE ₁₃	0.4	1.3	25	5	slotted cavity
UNIV. Michigan [131]	3	TE ₁₀ ^r /TE ₀₁ ^r	0.75	0.5(2.0)	5	1.3(0.4)	
	10	TE ₁₁	0.4	0.025	0.6	6	
NRL, Washington D.C. [122,128,129]	8.35-13		3.3	80	1000	0.4	4-5 modes
	35	TE ₆₂	0.6	2.0	100	8	
	35	TE ₁₃	1.15	2.5	275	10	
Tomsk Polytech. Inst. [123]	3.1		0.9	0.65	35	6	slotted cavity
			0.75	8.0(30)	1800	8	also viractor interaction
UNIV. Strathclyde [130]	100		0.2	0.22	6.3	14	

r: rectangular waveguide

Table XV: Present development status of relativistic gyrotron oscillators.

Institution	Frequency [GHz]	Mode	Harmonic No. s	Voltage [MV]	Current [kA]	Power [MW]	Efficiency [%]
IAP, Nizhny Novgorod [132]	21.4	TE ₁₁	1	0.25	0.01	100	4
	35.7	TE ₂₁	2	0.25	0.01	100	4
	49.1	TE ₃₁	3	0.25	0.01	75	3
	62.4	TE ₄₁	4	0.25	0.01	50	2
	74.9	TE ₅₁	5	0.25	0.01	50	2

Table XVI: Relativistic large orbit harmonic pulse gyrotrons ($\tau = 10$ ns).

Institution		Frequency [GHz]	Mode resonator	Power [kW]	Efficiency [%]	Pulse length [ms]
ABB, Baden	[29]	92	TEM _{00q}	90	10	10
CRPP, Lausanne	[9]	90.8	TEM _{00q}	150	15	5
		100	TEM _{00q}	90	11	15
		200(2Ω _c)	TEM _{00q}	8	3.5	15
NRL, Washington D.C. [89,133]		110	TEM _{00q}	80	8	0.013
		115	TEM _{00q}	431	12.7(SDC)	0.013
				197	16.1(SDC)	0.013
		120	TEM _{00q}	600	9	0.013
				200	12	0.013
Moscow-State Univ. [134]		35	TEM _{00q}	1	15	CW
		95	TEM _{00q}	1	15	CW
TOSHIBA, Ohtawara	[38]	112	TEM _{00q}	100	12	5
		120	TEM _{00q}	26	10(DEB)	3

SDC: Single-stage Depressed Collector

DEB: Dual Electron Beam (1 annular beam, 1 pencil beam)

Table XVII: Present development status of quasi-optical gyrotron oscillators.

9 Cyclotron autoresonance masers (CARMs)

Institution	Frequency [GHz]	Mode	Power [MW]	Efficiency [%]	Gain [dB]	B-Field [T]	Voltage [MV]	Current [kA]	Type
IAP	35.7	TE ₅₁	30	10	-	1.12	0.4	0.6	oscil.
IAP, IHCE	37.5	TE ₁₁	10	4	30	0.5	0.5	0.5	ampl.
IAP	38	TE ₁₁	13	26(0.65)	-	1.24	0.5	0.1(4)	oscil.
IAP, IHCE, JINR	50	TE ₁₁	30	10	-	0.7	1.0	0.3	oscil.
IAP	66.7	TE ₂₁	15	3	-	0.6	0.5	1.0	oscil.
IAP, IHCE, JINR	68	TE ₁₁	50	8	-	1.0	1.2	0.5	oscil.
IAP	69.8	TE ₁₁	6	4	-	0.6	0.35	0.4	oscil.
IAP [132,136-139]	125	TE ₄₁	10	2	-	0.9	0.5	1.0	oscil.
LLNL Livermore [140]	220	TE ₁₁	50	2.5	-	3.0	2.0	1.0	oscil.
MIT Cambridge [27,141,142]	27.8	TE ₁₁	1.9	5.3	-	0.6	0.45	0.080	oscil.
	30	TE ₁₁	0.1	3	-	0.64	0.3	0.012	oscil.
	32	TE ₁₁	0.11	2.3	-	0.63	0.32	0.015	oscil.
	35	TE ₁₁	10	3	45	0.7	1.5	0.25	ampl.
UNIV. Michigan [143]	15	TE ₁₁	7	1.5	-	0.45	0.4	1.2	oscil.
UNIV. Strathclyde [144]	14.3(2 Ω_c)	TE ₂₁	0.18	4(0.4)	-	0.2	0.3	0.015(0.15)	oscil.

IAP Nizhny Novgorod, IHCE Tomsk, JINR Dubna

Table XVIII: State-of-the-art of CARM experiments (short pulse).

Weakly Relativistic Pulse Gyroklystrons

Institution	Frequency [GHz]	Mode	No. of cavities	Power [kW]	Efficiency [%]	Gain [dB]	BW [%]	
NRL, Washington D.C. [24,89,145,146]	4.5	TE ₁₀	3	54	30	30		
	85	TE ₁₃	2	50		20		
	85.5	TEM ₀₀	2	82	19	18		QOGK
				82	30(SDC)	18		QOGK
IAP Nizhny Novgorod [147-154]	9.25	TE ₀₁	2	4	50	22	1.0	
			3	8	50	22	0.5	
	15.2	TE ₀₁	3	50	50	30	0.5	
	15.8	TE ₀₂	3	160	40	30	0.5	max. efficiency
	35.12(2 Ω_c)	TE ₀₂	2	258	18	17	0.3	tapered B-field
	35	TE ₀₂	2	300	22		0.3	2-cav. gyrptron
230				30		0.3	2-cav. gyrotron	
TORIY, Moscow [147,150]	35.2	TE ₀₂	2	750	24	20	0.6	max. power
			2	350	32	19	0.9	max. efficiency
	35.0	TE ₀₁	4	160	48	42	1.4	
			3	250	35	40	1.4	
IAP Nizhny Novgorod [155]	93.2	TE ₀₁	4	65	26	35	0.3	max. power
			4	57	34	40	0.3	max. efficiency
CPI ¹⁾ , Palo Alto [24]	10(2 Ω_c)	TE ₀₁	3	20	8.2	10	0.2	
	28	TE _{01/02}	2	76	9	30	0.2	
	35			65		30	0.2	

QOGK: Quasi-Optical Gyroklystron;

SDC: Single-stage Depressed Collector

¹⁾ Communications & Power Industries, formerly VARIAN

Weakly Relativistic CW Gyroklystrons

IAP Nizhny Novgorod	9.17	TE ₁₁	2	0.7	70	22	0.3	
IAP/ISTOK Moscow [151,152,155]	91.6	TE ₀₁	4	2.5	25	31	0.36	

Table XIXa: Weakly relativistic gyroklystron experimental results.

Institution	Frequency [GHz]	Mode	No. of cavities	Power [MW]	Efficiency [%]	Gain [dB]	BW [%]	
UNIV. MARYLAND [156-161]	9.87	TE ₀₁	2	24	30	33	0.25	
	9.87	TE ₀₁	3	27	32	36	0.2	max. power
			3	16	37	33	0.2	max. efficiency
			3	20	28	50	0.2	max. gain
	19.75(2 Ω_c)	TE ₀₂	2	32	29	27	0.15	
	29.57(3 Ω_c)	TE ₀₃	2	1.8	2.0	14	0.1	

Relativistic Pulsed Gyroklystrons

Table XIXb: Relativistic pulse gyroklystron experimental results.

Weakly Relativistic Pulse Gyro-TWTs

Institution	Frequency [GHz]	Mode	Power [kW]	Efficiency [%]	Gain [dB]	Bandwidth [%]	
UC LOS ANGELES [165-169]	9.3	TE ₁₀	55	11	27	11	diel.coat.waveg.
	15.7(2 Ω_c)	TE ₂₁	207	12.9	16	2.1	slotted waveg.
	16.2(8 Ω_c)	TE ₈₂	0.5	1.3	10	4.3	axis-encircl.beam
UNIV. HSINCHU [170,171]	35.8	TE ₁₁	18.4	18.6	18	10	
	35.8	TE ₁₁	27	16	35	7	2-stage severed
	34.2	TE ₁₁	62	21	33	12	2-stage lossy
NRL, Washington D.C. [24,172-174]	32.5	TE ₁₀	6.3	10	16.7	33	1-stage tapered
	35.5	TE ₁₀	8	16	25	20	2-stage tapered
	32.3	TE ₁₀	50	28	25	11	folded waveguide axis-encircl.beam
	34.3	TE ₀₁	16.6	7.8	20	1.4	
CPI ¹⁾ , Palo Alto [24,175,176]	5.18	TE ₁₁	120	26	20	7.3	MIG
	5.2	TE ₁₁	64	14	17.5	7.3	Pierce-helix gun
	35	TE ₁₁	50				Pierce-helix gun
	93.7	TE ₁₁	28	7.8	16	3	Pierce-helix gun

¹⁾ Communications & Power Industries, formerly VARIAN

Relativistic Pulse Gyro-TWTs

Institution	Frequency [GHz]	Mode	Power [MW]	Efficiency [%]	Gain [dB]	Bandwidth [%]	
MIT, Cambridge [177]	17.1(2 Ω_c)	TE ₂₁	2	4	40		Pierce-helix gun
	17.1(3 Ω_c)	TE ₃₁	4	6.6	51		Pierce-helix gun
NRL, Washington D.C. [178]	35	TE ₁₁	20	11	30		

Table XX: Present development status of gyro-TWTs (short pulse).

Weakly Relativistic Pulse Gyrotwistrons

Institution	Frequency [GHz]	Mode cavity	Mode output w.g.	Power [kW]	Efficiency [%]	Gain [dB]	BW [%]
NRL, Washington, D.C. [162]	4.5	TE ₁₀	TE ₁₀	73	22.5	37	1.5
IAP, Nizhny Novgorod [163]	9.2	TE ₀₁ (2 cav.)	TE ₀₁	5.6	35	20	0.9
				3.2	20	18	1.6

Relativistic Pulse Gyrotwistrons

Institution	Frequency [GHz]	Mode cavity	Mode output w.g.	Power [MW]	Efficiency [%]	Gain [dB]	BW [%]
UNIV. MARYLAND [164]	9.87	TE ₀₁	TE ₀₁	21.6	21	25.5	
	19.76	TE ₀₁ (9.88 GHz)	TE ₀₂ (2Ω _c)	12	11	21	

Table XXI: State-of-the-art of gyrotwistron experiments (short pulse).

Weakly Relativistic Pulse Gyro-BWOs

Institution	Frequency [GHz]	Mode	Power [kW]	Efficiency [%]	Bandwidth [%]
NRL, Washington D.C.	[179]	TE ₁₀ ^r	2	9	3
		TE ₁₀ ^r	6	15	13
UNIV. HSINCHU	[180]	TE ₁₁ ^c	20-67	6.5-21.7	5
			113	19	1
MIT, Cambr., LLNL, Liverm. [181]	140	TE ₁₂ ^c	2	2	9

r: rectangular waveguide; c: circular waveguide

Relativistic Pulse Gyro-BWOs (pulse duration = 0.1 - 1 μs)

Institution	Frequency [GHz]	Mode	Power [MW]	Efficiency [%]	BW [%]	Voltage [MV]	Current [kA]
UNIV. MICHIGAN [182,183]	4-6	TE ₁₁	55 (30)	8 (4.3)	1	0.7	1
	5-6 (2Ω _c)	TE ₁₁	1	0.15	4		
USAF PHILLIPS LAB.	4.2	TE ₂₁	4	1	1	0.4	1
Aberdeen [184,185]	4.4	TE ₀₁	0.15	0.04	1	0.4	1

Table XXII: First experimental results on gyro-BWOs (short pulse).

Institution	Frequency [GHz]	Mode	Power [kW]	Efficiency [%]	Pulse Length [ms]
UNIV. TOHOKU, Sendai [189-191]	10.0	TE ₁₁ ^r	10	36	0.02 magnetron- type cavity auto-res.
	10.5(2Ω _c)	TE ₃₁ ^c	0.7	10	
	10	TE ₂₁ ^c	1.3 1.5	7 25	

r: rectangular waveguide; c: circular waveguide

Table XXIII: Experimental results of peniotrons.

Institution	Frequency [GHz]	Mode	Power [kW]	Efficiency [%]	Pulse Length [ms]
UNIV. TOHOKU, Sendai					
TOSHIBA, Nasushiobara	69.85(3Ω _c)	TE ₀₂	8	6.75	0.2
UNIV. FUKUI [192]	140 (3Ω _c)	TE ₀₃	8	1	1

Table XXIV: Experimental results of gyropeniotrons.

11 Free electron masers (FEMs)

Institution	Frequency [GHz]	B _w [T]	λ _w [mm]	Mode	Power [MW]	Efficiency [%]	Gain [dB]	Voltage [MV]	Current [kA]	Accelerator	Pulse-Length [μs]	Type
CEA/CESTA, LeBarp [198]	33-36	0.3	80	TE ₁₁ ^c	50	7.1(0.06)	43	1.75	0.4(50)	Pulse Line	0.01	amplifier
[199]	35	0.11	120	TE ₁₁ ^c	15	1.5	22	2.2	0.45	Ind. LINAC	0.03	amplifier
COLUMBIA U. NY [200]	24	0.05	34	TE ₁₁ ^c /TM ₁₁ ^c	2	3.3	20	0.6	0.1	Pulse Line	0.15	amplifier
	150	0.18	17	TE ₁₁ ^c	5	4		0.8	0.15	Pulse Line	0.15	oscillator
DLR, Stuttgart [201]	100	0.1	20	TE ₀₂ ^c	1	2		0.5	0.15	Pulse Line	0.03	spont.emiss.
ENEA Frascati [202]	110-150	0.61	25	TE ₀₁ ^r	0.0015	0.19		2.3	0.00035	Microtron	5.5	oscillator
EP Palaiseau [203]	120	0.03	20	TE ₁₁ ^c	11.5	6.4		0.6	0.3	Electrostatic	0.02	superrad.
General Electric	2.6	0.04		TE ₀₁ ^r	1.2	10		0.17	0.07	Electrostatic		oscillator
Microwave Lab, Palo Alto [195]	2.8	0.04		TE ₀₁ ^r	0.9	9.2	6	0.14	0.07	Electrostatic		amplifier
	15.7			TE ₀₁ ^r	1.65	6		0.23	0.125	Electrostatic		oscillator
	54			TE ₀₁ ^r	0.15	6	30	0.07	0.04	Electrostatic		amplifier
IEE, China [197]	35	0.31	110		140	5.2	57	3.4	0.95	Ind. LINAC	0.05	amplifier
IAP, Nizhny Novgorod [204-206]	16.7	0.02		TE ₀₁ ^c	300	11		0.6	4.5	Electrostatic	0.03	oscillator
	42.8-47.2	0.03	24	TE ₁₀ ^r	7	12(0.5)		0.5	0.12(3)	Pulse Line	0.015	oscill./CRM
IAP, N.N./INP Novosib. [207]	75	0.08	40	TE ₁₁ ^c	200	8		1.0	2.4	Pulse Line	2	oscillator
JINR Dubna/IAP N. Novg.	29.3	0.11	60	TE ₁₁ ^c	6	5(4)		0.8	0.15(0.2)	Ind. LINAC	0.2	oscillator
	31.0	0.10	60	TM ₁₁ ^c	39	24(19)		0.8	0.2(0.25)	Ind. LINAC	0.2	oscillator
	38.2	0.06	60	TM ₁₂ ^c	3	3(2)		0.8	0.15(0.2)	Ind. LINAC	0.2	oscillator
JINR Dubna [208]	35	0.19	72	TE ₁₁ ^c	30	10		1.5	0.2	Ind. LINAC	0.2	amplifier
ILE Osaka [209]	250	0.05	30	TE ₁₁ ^c	0.6	0.5	110	0.6	0.2	Ind. LINAC	0.04	amplifier
ILT/ILE Osaka [210]	60-110	0.71	60	TE ₀₁ ^r	0.01	0.2		9.0	0.05	RF LINAC	4×10 ⁻⁶	oscillator
ISAS, Sagami-hara [211]	11.8	0.09	32.7	TM _{B1} ^c	3	1		0.43	0.19	Pulse Line	0.4	oscillator
JAERI, Ibaraki [212-213]	45	0.18	45	TE ₁₁ ^c	6	2.9(0.4)	52	0.82	0.25(2.0)	Ind. LINAC	0.03	amplifier
KAERI, Korea [214]	27	0.13	32	TM ₁₁ ^c	0.001	0.15		0.4	0.0017	Electrostatic	10-30	oscillator
KEK, Tsukuba [215-217]	9.4	0.121	160	TE ₀₁ ^r	120	17.8(6.2)	21	1.5	0.45(1.3)	Ind. LINAC	0.015	amplifier
LLNL, Livermore [17,218]	34.6	0.37	98	TE ₀₁ ^r	1000	34(7.2)	52	3.5	0.85(4.0)	Ind. LINAC	0.02	amplifier
[17,218,219]	140	0.17	98	TE ₁₁ ^c	2000	13.3(10)	58	6.0	2.5(3.0)	Ind. LINAC	0.02	amplifier
MIT, Cambridge [141,220-223]	9.3	0.02	33	TE ₁₁ ^c	0.1	10	6	0.18	0.0055	Electrostatic	0.02	amplifier
	27.5	0.05	30	TE ₁₁ ^c	1	10.3(6.3)	-	0.32	0.03(0.05)	Electrostatic	1	oscillator
	33.4	0.15	32	TE ₁₁ ^c	61	27	50	0.75	0.3	Pulse Line	0.025	amplifier
	35.2	0.05	30	TE ₁₁ ^c	0.8	8.6(5.2)	26	0.31	0.03(0.05)	Electrostatic	1	amplifier
NRL, Washington D.C. [224-225]	13.2-16.6	0.1	25.4	TE ₁₁ ^c	4.2	18	29	0.245	0.094	Modulator	1.2	amplifier
	23-31	0.06	40	TE ₀₁ ^c	4	3		0.7	0.2	Ind. LINAC	0.035	amplifier
	35	0.14	30	TE ₁₁ ^c	17	3.2	50	0.9	0.6	Pulse Line	0.02	amplifier
	75	0.08	30	TE ₁₁ ^c	75	6	50	1.25	1.0	Pulse Line	0.02	superrad.
NSWC/MRC, Wash. D.C. [197]	95	0.2	100		10	4		2.5	0.1	Pulse Line	0.25	oscillator
RI, Moscow [226]	6-25	0.03	48	TE ₁₁ ^c /TM ₀₁ ^c	10	1.7		0.6	1	Pulse Line	2	spont.emiss.
SIAE, Chengdu [227]	37	0.125	34.5	TE ₁₁ ^c	7.6	5.4		0.5	0.28	Electrostatic	0.015	oscillator
SIOFM, Shanghai [228,229]	37.5	0.12	21	TE ₁₁ ^c	12	3.7	50	0.4	0.8	Pulse Line	0.02	amplifier
	39	0.126	22	TM ₀₁ ^c	14	4.4		0.4	0.8	Pulse Line	0.02	oscillator
	83-95	0.15	10	TE ₁₁ ^c /TM ₀₁ ^c	1	0.7		0.35	0.4	Pulse Line	0.02	spont.emiss.
TRW, Redondo Beach [230]	35	0.16	20	TE ₀₁ ^r	0.1	9.2		0.3	0.004	Electrostatic	10	oscillator
	35	0.16	20	TE ₀₁ ^r	0.002	6.9	3	0.29	0.0001	Electrostatic	10	amplifier
UNIV. Liverpool [231]	8-12.4	0.1	30	TE ₁₀ ^r	2×10 ⁻⁵	0.9		0.12	1.8×10 ⁻⁵	Electrostatic	CW	oscillator
	9.9	0.017	19	TE ₁₀ ^r	10 ⁻⁶	0.2	18	0.05	1×10 ⁻⁵	Electrostatic	CW	amplifier
UNIV. Maryland [232,233]	86	0.38	9.6	TE ₀₁ ^r	0.25	3.3	24	0.45	0.017	Pulse Line	0.02	amplifier
UCSB Santa Barbara [234]	120-880	0.15	71.4		0.027	0.5		2-6	0.002	Electrostatic	1-20	oscillator
UNIV. Tel Aviv [235]	4.5	0.03	44.4	TE ₁₀ ^r	0.0035	6.3		0.07	0.0008	Electrostatic	3	oscillator
UNIV. Twente [236]	35	0.19	30	TE ₁₁ ^c /TM ₀₁ ^c	2.3	0.6		0.5	0.75	Pulse Line	0.1	spont.emiss.

r: rectangular waveguide; c: circular waveguide

Table XXV: State-of-the-art of millimeter- and submillimeter wave FEMs.

mmw frequency	130-260 GHz	f_{mmw}
Rapid tuneability of f_{mmw}	+/- 5%	Δf_{mmw}
Tuning time over 10% of f_{mmw}	10 ms	Δt_{mmw}
mmw output power	1 MW	P_{mmw}
Electron energy	1.35-2 MeV	T_e
Electron beam current	12 A	I_e
Electron loss current	< 20 mA	I_{loss}
Normalized beam emittance	80π mm mrad	ϵ_n
Pulse length	100 ns	t_p
Duty cycle	10^{-3}	
Overall efficiency (grid to P_{mmw})	60%	η_p
Linear gain	7	Γ_{lin}
Gain in saturation	3.5	Γ_{sat}
Waveguide mode	HE ₁₁	
Type of waveguide	rectangular corrugated	
Cross section of primary waveguide	15*20 mm ²	$a*b$
Separation mmw beam, electron beam	via stepped waveguide	
Undulator period	40 mm	λ_u
Undulator gap	25 mm	g_u
Peak undulator field, section 1	0.2 T	B_{u1}
Number of full cells, section 1	20	N_{u1}
Peak undulator field, section 2	0.16 T	B_{u2}
Number of full cells, section 2	14	N_{u2}
Total number of cells (incl. matching)	38	N_u
Length of undulator	1.58 m	L_u

Table XXVI: Design parameters of the planned FOM-FEM [196]

12 Comparison of gyrotron and FEM for nuclear fusion

Table XXVII lists a comparison of the main performance parameters and features of gyrotron oscillators and FEMs for ECRH of plasmas in nuclear fusion research. The important advantage of the FEM is its a and continuous frequency tunability and the possibility of high unit power but the gyromonotron is a much simpler device. Up to now, the cylindrical cavity gyrotron is the only millimeter wave source which has had an extensive on-the-field experience during fusion plasma heating experiments over a wide range of frequencies and power levels (8-159 GHz, 0.1-1.0 MW).

	Gyrotron Oscillator (cyclotron resonance maser axial magnetic field)	Free Electron Maser Oscillator (periodic transverse magnetic field)
1. Beam voltage	low (≤ 100 kV)	high (0.2 - 6 MV)
2. Magnetic field (140 GHz)	high (5.5 T, 1st harmonic)	low (0.2 T, wiggler)
3. Frequencies	8-650 GHz	9 GHz - visible
4. Frequency tunability	$\Delta U_{\text{beam}} + \Delta U_{\text{mod}}$ fast step tuning (5 %) ΔB : slow step tuning (25 %)	ΔU_{beam} fast continuous tuning (10%) slow mechanical tuning (50%)
5. Electron beam	magnetron injection gun	Pierce electron gun, acceleration and deceleration tubes, beam optics
6. Ohmic losses in cavity	cutoff cavity 2 kW/cm ²	oversized circuit far away from cut off
7. Power density in cavity	high	low
8. Longitudinal mode competition in cavity	single mode operation	nonlinear temporal dynamics can bring broad frequency spectrum (noise source?)
9. Linearly polarized output mode	internal quasi-optical mode converter	linearly polarized, low-order resonator mode
10. Number of internal quasi- optical mirrors	2-4 on ground potential 0.9 % ohmic losses	15-25 phase coherence required mostly on 2 MV potential 6 % ohmic losses
11. Absorbed power on first mirror (1 MW, 140 GHz)	3 kW	12 kW
12. Internal microwave diagnostics	not required	required
13. Output power (140 GHz) present status	high average power 0.6 MW/3 s (coax. 1.2 MW / 1 m.s)	2 GW/20 ns but very low duty cycle (LLNL amplifier)
14. Exp. system efficiency without energy recovery	high 40 %	low < 10 %
15. Theor. system efficiency with depressed collector	60 % (exp. 51 %)	60 % (but halo current ?)
16. Physical size	3 m x 3 m x 3 m	12 m x 3 m x 3 m
17. Power per unit (140 GHz)	1 MW (coax., 2.5 MW)	5 MW

Table XXVII: Comparison of parameters and features of gyrotron oscillators and FEMs for ECRH.

Acknowledgments

The author would like to thank M. Pain and P. Garin (CEA, Cadarache), S. Alberti and M.Q. Tran (CRPP, Lausanne), E. Borie, O. Braz, G. Dammertz, L. Feher, R. Heidinger, C. Iatrou, S. Illy, S. Kern, M. Kuntze, G. Link, G. Michel, B. Piosczyk and G. Soudée (Forschungszentrum Karlsruhe), A.G.A. Verhoeven (FOM Institute "Rijnhuizen"), T. Idehara (Fukui University), J.L. Doane, R. Freeman and C.P. Moeller (General Atomics, San Diego), M.V. Agapova, A. Litvak and V.E. Myasnikov (GYCOM), V.L. Bratman, G.G. Denisov, V.A. Flyagin, V.A. Goldenberg, A.N. Kuftin, M.I. Petelin, A.B. Pavelyev and V.E. Zapevalov (IAP, Nizhny Novgorod), W. Kasperek, G.A. Müller, P.G. Schüller and D. Wagner (IPF, Stuttgart), V. Erckmann and H.P. Laqua (IPP, Garching), M. Makowski (ITER, Worksite Garching), T. Imai and K. Sakamoto (JAERI, Naka), K. Kreischer and R.J. Temkin (MIT, Cambridge), H. Asano and T. Kikunaga (MITSUBISHI, Amagasaki), H. Freund (NRL, Washington D.C.), Y. Tsunawaki (Osaka Sangyo University), G. Faillon, E. Giguet, P. Thouvenin and C. Tran (THOMSON TUBES ELECTRONIQUES, Velizy), K. Yokoo (Tohoku University Sendai), T. Okamoto and Y. Okazaki (TOSHIBA, Ohtawara), D.B. McDermott (UC, Davis), V.L. Granatstein and W. Lawson (University of Maryland) and H.P. Bohlen, M.J. Cattelino, T.S. Chu, K. Felch and H. Jory (CPI, Palo Alto). This work could not have been done without their help, stimulating suggestions and useful discussions. The author also wish to express his deep gratitude to Mrs. Mosbacher for her thorough typing of this manuscript.

This work was supported by the European Community as part of the European Fusion Technology Program under the auspices of the Project Nuclear Fusion (Projekt Kernfusion) at the Forschungszentrum Karlsruhe, Association EURATOM-FZK.

References

- [1] Flyagin, V.A., Gaponov, A.V., Petelin, M.I., Yulpatov, V.K., 1977, The gyrotron. IEEE Trans. Microwave Theory and Techniques, **MTT-25**, 514-521.
Andronov, A.A., Flyagin, V.A., Gaponov, A.V., Goldenberg, A.L., Petelin, M.I., Usov, V.G., Yulpatov, V.K., 1978, The gyrotron: high power sources of millimetre and submillimetre waves. Infrared Physics, **18**, 385-393.
Petelin, M.I., Physics of advanced gyrotrons. Plasma Phys. and Contr. Nucl. Fusion, **35**, Supplement B, 343-341.
- [2] Flyagin, V.A., Goldenberg, A.L., Nusinovich, G.S., 1984, Powerful gyrotrons, in Infrared and Millimeter Waves, **Vol. 11**, ed. K.J. Button, Academic Press, New York, 179-226.
- [3] Flyagin, V.A., Nusinovich, G.S., 1988, Gyrotron oscillators. Proceedings of the Institute of Electrical and Electronics Engineers, **76**, 644-656 and, 1985, Powerful gyrotrons for thermonuclear research, in Infrared and Millimeter Waves, **Vol.13**, ed. K.J. Button, Academic Press, New York, 1-17.
- [4] Felch, K., Huey, H., Jory, H., 1990, Gyrotrons for ECH application. J. Fusion Energy, **9**, 59-75.
- [5] Prater, R., 1990, Recent results on the application of electron cyclotron heating in tokamaks. J. Fusion Energy, **9**, 19-30.
Makowski, M., 1996, ECRF Systems for ITER. IEEE Trans. Plasma Science, **24**, 1023-1032.
- [6] Erckmann, V., WVII-AS Team, Kasperek, W., Müller, G.A., Schüller, P.G., and Thumm, M., 1990, Electron cyclotron resonance heating transmission line and launching system for the Wendelstein VII-AS stellarator. Fusion Technology, **17**, 76-85.
- [7] Thumm, M., 1995, Advanced electron cyclotron heating systems for next step fusion experiments. Fusion Engineering and Design, **30**, 139-170.
Thumm, M., 1994, Progress in the development of high-power millimeter- and submillimeter wave gyrotrons and of free electron masers, Archiv für Elektrotechnik **77**, 51-55.
- [8] Thumm, M., Kasperek, W., 1995, Recent advanced technology in electron cyclotron heating systems. Fusion Engineering and Design, **26**, 291-317.
Henle, W., Jacobs, A., Kasperek, W., Kumric, H., Müller, G.A., Schüller, P.G., Thumm, M., Engelman, F., Rebuffi, L., 1991, Conceptual study of multi-megawatt millimeter wave transmission and antenna systems for electron cyclotron wave applications in NET/ITER. Fusion Technology **1990**, eds. B.E. Keen, M. Huguet, R. Hemsworth. Elsevier Science Publishers B.V., 238-242.
- [9] Alberti, S., Tran, M.Q., Hogge, J.P., Tran, T.M., Bondeson, A., Muggli, P., Perrenoud, A., Jödicke, B., Mathews, H.G., 1990, Experimental measurements on a 100 GHz frequency tunable quasi-optical gyrotron. Phys. Fluids, **B2**, 1654-1661.
Hogge, J.P., Tran, T.M., Paris, P.J., Tran, M.Q., 1996, Operation of a quasi-optical gyrotron with a gaussian output coupler. Phys. Plasmas, **3**, 3492-3500.
- [10] Kreischer, K.E. Temkin, R.J., 1987, Single-mode operation of a high-power, step-tunable gyrotron. Phys. Rev. Lett., **59**, 547-550.
- [11] Kurbatov, V.I., Malygin, S.A., Vasilyev, E.G., 1990, Commercial gyrotrons for thermonuclear investigations. Proc. Int. Workshop on Strong Microwaves in Plasmas, Suzdal, Inst. of Applied Physics, Nizhny Novgorod, 1991, 765-772.
Bogdanov, S.D., Kurbatov, V.I., Malygin, S.A., Orlov, V.B., Tai, E.M., 1993, Industrial gyrotrons development in Salut. Proc. 2nd Int. Workshop on Strong Microwaves in Plasmas, Moscow - Nizhny Novgorod - Moscow, ed. A.G. Litvak, Inst. of Applied Physics, Nizhny Novgorod, 1994, **Vol. 2**, 830-835.

- [12] Flyagin, V.A., Kuftin, A.N., Luchinin, A.G., Nusinovich, G.S., Pankratova, T.B., Zapevalov, V.E., 1989, Gyrotrons for electron cyclotron heating and active plasma diagnostics. Proc. Joint IAEA Techn. Committee Meeting on ECE and ECRH (EC-7 Joint Workshop), Hefei, P.R. China, 355-372.
Flyagin, V.A., Luchinin, A.G., Nusinovich, G.S., 1983, Submillimeter-wave gyrotrons: theory and experiment. *Int. J. Infrared and Millimeter Waves*, **4**, 629-637.
- [13] Bykov, Y., Goldenberg, A.F.L., Flyagin, V.A., 1991, The possibilities of material processing by intense millimeter-wave radiation. *Mat. Res. Soc. Symp. Proc.*, **169**, 41-42.
Sklyarevich, V., Detkov, A., Shevelev, M., Decker, R., 1992, Interaction between gyrotron radiation and powder materials, *Mat. Res. Soc. Symp. Proc.*, **269**, 163-169.
Gaponov-Grekhov, A.V., Granatstein, V.L., 1994, *Application of high-power microwaves*. Artech House, Boston, London.
- [14] Granatstein, V.L., Lawson, W., Latham, P.E., 1988, Feasibility of 30 GHz gyrokystron amplifiers for driving linear supercolliders. *Conf. Digest, 13th Int. Conf. on Infrared and Millimeter Waves, Honolulu, Hawaii, Proc.*, SPIE **1039**, 230-231.
Granatstein, V.L., Nusinovich, G.S., 1993, On the optimal choice of microwave systems for driving TeV linear colliders. *Proc. 2nd Int. Workshop on Strong Microwaves in Plasmas, Moscow - Nizhny Novgorod - Moscow*, ed. A.G. Litvak, Inst. of Applied Physics, Nizhny Novgorod, 1994, **Vol. 2**, 575-586.
Granatstein, V.L., Lawson, W., 1996, Gyro-amplifiers as candidate RF drivers for TeV linear colliders. *IEEE Trans. on Plasma Science*, **24**, 648-665.
- [15] Manheimer, W.M., Mesyats, G.A., Petelin, M.I., 1993, Super-high-power microwave radars, *Proc. 2nd Int. Workshop on Strong Microwaves in Plasmas, Moscow - Nizhny Novgorod - Moscow*, ed. A.G. Litvak, Inst. of Applied Physics, Nizhny Novgorod, 1994, **Vol. 2**, 632-641.
Manheimer, W.M., 1992, On the possibility of high power gyrotrons for super range resolution radar and atmospheric sensing. *Int. J. Electronics*, **72**, 1165-1189.
- [16] Bratman, V.L., Denisov, G.G., Ginzburg, N.S., and Petelin, M.I., 1983, FEL's with Bragg reflection resonators. Cyclotron autoresonance masers versus ubitrons. *I.E.E.E. Journal Quantum Electronics*, **QE-19**, 282-296.
- [17] Stone, R.R., Jong, R.A., Orzechowski, T.J., Scharlemann, E.T., Throop, A.L., Kulke, B., Thomassen, K.I., Stallard, B.W., 1990, An FEL-based microwave system for fusion. *J. Fusion Energy*, **9**, 77-101.
- [18] Hirshfield, J.L., Granatstein, V.L., 1977, Electron cyclotron maser - an historical survey. *IEEE Trans. Microwave Theory Tech.*, **MTT-25**, 522-527.
- [19] Twiss, R.Q., 1958, Radiation transfer and the possibility of negative absorption in radio astronomy. *Aust. J. Phys.*, **11**, 564-579; Twiss, R.Q., Roberts, J.A., 1958, Electromagnetic radiation from electrons rotating in an ionized medium under the action of a uniform magnetic field. *Aust. J. Phys.*, **11**, 424.
- [20] Schneider, J., Stimulated emission of radiation by relativistic electrons in a magnetic field. 1959, *Phys. Rev. Lett.*, **2**, 504-505.
- [21] Gaponov, A.V., Addendum, 1959, *Izv. VUZ Radiofiz.*, **2**, 837, an addendum to Gapanov, A.V., 1959, Interaction between electron fluxes and electromagnetic waves and waveguides. *Izv. VUZ Radiofiz.*, **2**, 450-462.
- [22] Hirshfield, J.L., Wachtel, J.M., 1964, Electron cyclotron maser. *Phys. Rev. Lett.*, **12**, 533-536.
- [23] Gaponov, A.V., Petelin, M.I. and Yulpatov, V.K., 1967, The induced radiation of excited classical oscillators and its use in high frequency electronics. *Izv. VUZ Radiofiz.* **10**, 1414 (*Radiophys. Quantum Electr.*, **10**, 794-813).

- [24] Granatstein, V.L., Alexeff, I., eds., 1987, High-power microwave sources. Artech House, Boston, London.
Gaponov-Grekhov, A.V., Granatstein, V.L., 1994, Application of high-power microwaves. Artech House, Boston, London.
- [25] Benford, J. Swegle, J., 1992, High-power microwave sources. Artech House, Boston, London.
- [26] Edgcombe, C.J., ed., 1993, Gyrotron oscillators-their principles and practice. Taylor & Francis, London.
- [27] Pendergast, K.D., Danly, B.G., Menninger, W.L., Temkin, R.J., 1992, A long-pulse CARM oscillator experiment. *Int. J. Electronics*, **72**, 983-1004.
- [28] Granatstein, V.L., Read, M.E., Barnett, L.R., 1982, Measured performance of gyrotron oscillators and amplifiers, in *Infrared and Millimeter Waves*, Vol. 5, ed. K.J. Button, Academic Press, New York, 267-304.
- [29] Mathews, H.-G., Tran, M.Q., 1991, private communication, ABB, Baden, Switzerland.
- [30] Chen, Z.-G., 1992, private communication, Institute of Electronics, Academia Sinica (IEAS), Beijing, P.R. China and Guo, H., Wu, D.S., Liu, G., Miao, Y.H., Qian, S.Z., Qin, W.Z., 1990, Special complex open-cavity and low-magnetic field high power gyrotron. *IEEE Trans. on Plasma Science*, **18**, 326-333.
- [31] Maekawa, T., Teremuchi, Y., Yoshimura, S., Matsunaga, K. 1996, ECH system using an 88 GHz gyrotron for the WT-3 tokamak, Proc. 11th Topical Conference on RF in Plasmas, Palm Springs, AIP Conf. Proc., **355**, 437-440.
- [32] Idehara, T., 1995, private communication, Fukui University Japan.
- [33] Behm, K, Jensen, E., 1986, 70 GHz gyrotron development at Valvo. Conf. Digest 11th Int. Conf. on Infrared and Millimeter Waves, Pisa, 218-220.
- [34] Bogdanov, S.D., Gyrotron Team, Solujanava, E.A. 1994, Industrial gyrotrons from GYCOM. Conf. Digest 19th Int. Conf. on Infrared and Millimeter Waves, Sendai, JSAP Catalog No.: AP 941228, 351-352.
- [35] Goldenberg, A.L., Litvak, A.G., 1995, Recent progress of high-power millimeter wavelength gyrodevices. *Phys. Plasmas*, **2**, 2562-2572.
- [36] Goldenberg, A.L., Denisov, G.G., Zapevalov, V.E., Litvak, A.G., Flyagin, V.A., 1996, *Isv. VUZ Radiofiz.* **39**, 635-670.
- [37] Mourier, G., 1990, Current gyrotron development at Thomson Tubes Electroniques. Proc. Int. Workshop on Strong Microwaves in Plasmas, Suzdal, Inst. of Applied Physics, Nizhny Novgorod, 1991, 751-764 and, 1993, private communication.
- [38] Nagashima, T., Sakamoto, K., Maebara, S., Tsuneoka, M., Okazaki, Y., Hayashi, K., Miyake, S., Kariya, T., Mitsunaka, Y., Itoh, Y., Sugawara, T., Okamoto, T., 1990, Test results of 0.5 MW gyrotron at 120 GHz and 1.5 MW at 2 GHz Klystron for fusion application. Proc. Int. Workshop on Strong Microwaves in Plasmas, Suzdal, Inst. of Applied Physics, Nizhny Novgorod, 1991, 739-750 and, Okazaki, Y., 1994, private communication, Toshiba, Ohtawara, Japan.
- [39] Lawrence Ives, R., Jory, H., Neilson, J., Chodorow, M., Feinstein, J., LaRue, A.D., Zitelli, L., Martorana, R., 1993, Development and test of a 500 kW, 8-GHz gyrotron. *IEEE Trans. on Electron Devices*, **40**, 1316-1321.
- [40] Felch, K., Chu, T.S., Feinstein, J., Huey, H., Jory, H., Nielson, J., Schumacher, R., 1992, Long-pulse operation of a gyrotron with beam/rf separation. Conf. Digest 17th Int. Conf. on Infrared and Millimeter Waves, Pasadena, Proc., SPIE **1929**, 184-195.

- [41] Shimosuma, T., Sato, M., Takita, Y., Kubo, S., Idei, H., Ohkubo, K., Kuroda, T. Tubokawa, Y., Huey, H., Jory, H., 1994, Development of a high power 84 GHz gyrotron. Conf. Digest 19th Int. Conf. on Infrared and Millimeter Waves, Sendai, JSAP Catalog No.: AP 941228, 65-66.
Sato, M., Shimosuma, T. Takita, Y., Kubo, S., Idei, H., Ohkubo, K., Kudora, T., Watari, T., Loring, Jr., M., Chu, S., Felch, K., Huey, H., 1995, Conf. Digest 20th Int. Conf. on Infrared and Millimeter Waves, Lake Buena Vista (Orlando), Florida, 195-196.
- [42] Thumm, M., 1986, High power mode conversion for linearly polarized HE_{11} hybrid mode output. Int. J. Electronics, **61**, 1135-1153.
- [43] Borie, E., Dammertz, G., Gantenbein, G., Kuntze, M., Möbius, A., Nickel, H.-U., Piosczyk, B., Thumm, M., 1993, 0.5 MW/140 GHz $TE_{10,4}$ Gyrotron with built-in highly efficient quasioptical converter. Conf. Digest 18th Int. Conf. on Infrared and Millimeter Waves, Colchester (Essex, UK), Proc., SPIE **2104**, 519-520.
Thumm, M., Borie, E., Dammertz, G., Kuntze, M., Möbius, A., Nickel, H.-U., Piosczyk, B., Wien, A., 1993. Development of high-power 140 GHz gyrotrons for fusion plasma applications. Proc. 2nd Int. Workshop on Strong Microwaves in Plasma, Moscow - Nizhny Novgorod -Moscow, Inst. of Applied Physics, Nizhny Novgorod, 1994, Vol. 2, 670-689.
- [44] Gantenbein, G., Borie, E., Dammertz, G., Kuntze, M., Nickel, H.-U., Piosczyk, B., Thumm, M., 1994, Experimental results and numerical simulations of a high power 140 GHz gyrotron. IEEE Trans. Plasma Science, **22**, 861-870.
- [45] Thumm, M., Borie, E., Dammertz, G., Höchtl, O., Kuntze, M., Möbius, A., Nickel, H.-U., Piosczyk, B., Semmler, C., Wien, A., 1994, Development of advanced high-power 140 GHz gyrotrons at KfK. Conf. Digest 19th Int. Conf. on Infrared and Millimeter Waves, Sendai, JSAP Catalog No.: AP 941228, 57-58.
- [46] Thumm, M., Braz, O., Dammertz, G., Iatrou, C.T., Kuntze, M., Piosczyk, B., Soudeé, G., 1995, Operation of an advanced, step-tunable 1 MW gyrotron at frequencies between 118 GHz and 162 GHz. Conf. Digest 20th Int. Conf. on Infrared and Millimeter Waves, Lake Buena Vista (Orlando), Florida, 199-200.
Dammertz, G., Braz, O., Iatrou, C.T., Kuntze, M., Möbius, A., Piosczyk, B., Thumm, M., 1995, Highly efficient long-pulse operation of an advanced 140 GHz, 0.5 MW gyrotron oscillator. Conf. Digest 20th Int. Conf. on Infrared and Millimeter Waves, Lake Buena Vista (Orlando), Florida, 285-286.
Piosczyk, B., Iatrou, C.T., Dammertz, G., Thumm, M., 1995, Operation of gyrotrons with single-stage depressed collectors. Conf. Digest 20th Int. Conf. on Infrared and Millimeter Waves, Lake Buena Vista (Orlando), Florida, 491-492.
- [47] Shimosuma, T., Kikunaga, T., Asano, H., Yasojima, Y., Miyamoto, K., Tsukamoto, T., 1993, A 120 GHz high-power whispering-gallery mode gyrotron. Int. J. Electronics, **74**, 137-151.
- [48] Asano, H., Kikunaga, T., Shimosuma, T., Yasojima, Y., Tsukamoto, T., 1994, Experimental results of a 1 Megawatt gyrotron. Conf. Digest 19th Int. Conf. Of Infrared and Millimeter Waves, Sendai, JSAP Catalog No.: AP 941228, 59-60.
- [49] Agapova, M.V., Alikae, V.V., Axenova, L.A., Bogdashov, A.A., Borshchegovsky, A.S., Keyer, A.P., Denisov, G.G., Flyagin, V.A., Fix, A.Sh., Ilyin, V.I., Ilyin, V.N., Khmara, V.A., Kostyna, A.N., Kuftin, A.N., Myasnikov, V.E., Nichiporenko, V.O., Popov, L.G., Zapevalov, V.E., Zakirov, F.G., 1995, Long-pulse 110 GHz/1MW gyrotron. Conf. Digest 20th Int. Conf. on Infrared and Millimeter Waves, Lake Buena Vista (Orlando), Florida, 205-206.

- [50] Giguet, E., Dubrovin, A., Krieg, J.M., Thouvenin, Ph., Tran, C., Garin, P., Pain, M., Alberti, S., Tran, M.Q., Whaley, D.R., Borie, E., Braz, O., Möbius, A., Piosczyk, B., Thumm, M., Wien, A., 1995, Operation of a 118 GHz - 0.5 MW gyrotron with cryogenic window: design and long pulse experiments. Conf. Digest 20th Int. Conf. on Infrared and Millimeter Waves, Lake Buena Vista (Orlando), Florida, 339-340.
- [51] Alberti, S., Braz, O., Garin, P., Giguet, E., Pain, M., Thouvenin, P.H., Thumm, M., Tran, C., Tran, M.Q., 1996, Long pulse operation of a 0.5 MW - 118 GHz gyrotron with cryogenic window. Proc. 21st Int. Conf on Infrared and Millimeter Waves, Berlin, AF1.
- [52] Sakamoto, K., Tsuneoka, M., Maebava, S., Kasugai, A., Fujita, H., Kikuchi, M., Yamamoto, T., Nagashima, T., Kariya, T., Okazaki, Y., Shirai, N., Okamoto, T. Hayashi, K., Mitsunaka, Y., Hirata, Y., 1992, Development of a high power gyrotron for ECH of tokamak plasma. Conf. Digest 17th Int. Conf. on Infrared and Millimeter Waves, Pasadena, SPIE **1929**, 188-189.
- [53] Sakamoto, K., Tsuneoka, M., Kasugai, A., Maebara, S., Nagashima, T., Imai, T., Kariya, T., Okazaki, Y., Shirai, N., Okamoto, T., Hayashi, K., Mitsunaka, Y., Hirata, Y., 1993, Development of a high power gyrotron for fusion application in JAERI. Proc. 2nd Int. Workshop on Strong Microwaves in Plasmas, Moscow - Nizhny Novgorod - Moscow, ed. A.G. Litvak, Inst. of Applied Physics, Nizhny Novgorod, 1994, **Vol. 2**, 601-615.
- [54] Sakamoto, K., Tsuneoka, M., Kasugai, A., Takahashi, K., Maebara, S., Imai, T., Kariya, T., Okazaki, Y., Hayashi, K., Mitsunaka, Y., Hirata, Y., 1994, Development of 110 GHz CPD gyrotron. Conf. Digest 19th Int. Conf. on Infrared and Millimeter Waves, Sendai, JSAP Catalog No.: AP 941228, 63-64.
- [55] Sakamoto, K., Tsuneoka, M., Kasugai, A., Imai, T., Kariya, T., Hayashi, K., Mitsunaka, Y., 1994, Major improvement of gyrotron efficiency with beam energy recovery. Phys. Rev. Lett., **73**, 3532-3535.
- [56] Hayashi, K., Hirata, Y., Mitsunaka, Y., 1996, Startup analysis of a gyrotron power supply system for depressed-collector operation. Proc. 21st Int. Conf. on Infrared and Millimeter Waves, Berlin, AM11.
- [57] Felch, K., Chu, T.S., DeHope, W., Huey, H., Jory, H., Nielson, J., Schumacher, R., 1994, Recent test results on a high-power gyrotron with an internal, quasi-optical converter. Conf. Digest 19th Int. Conf. on Infrared and Millimeter Waves, Sendai, JSAP Catalog No.: AP 941228, 333-334.
- [58] Neilson, J.M., Felch, K., Chu, T.S., Feinstein, J., Hess, C., Huey, H.E., Jory, H.R., Mizuhara, Y.M., Schumacher, R., 1995, Design and tests of a gyrotron with a radially-extracted electron beam. IEEE Trans. on Plasma Science, **23**, 470-480.
- [59] Felch, K., Borchard, P., Chu, T.S., Jory, H., Loring, Jr., C.M., Neilson, J., Lorbeck, J.A., Blank, M., 1995, Long-pulse tests on a high-power gyrotron with an internal, quasi-optical converter. Conf. Digest 20th Int. Conf. on Infrared and Millimeter Waves, Lake Buena Vista (Orlando), Florida, 191-192.
- [60] Felch, K., Blank, M., Borchard, P., Chu, T.S., Feinstein, J., Jory, H.R., Lorbeck, J.A., Loring, C.M., Mizuhara, Y.M., Nielson, J.M., Schumacher, R., Temkin, R.J., 1996, Long-pulse and CW tests of a 110 GHz gyrotron with an internal, quasi-optical converter. IEEE Trans. on Plasma Science, **24**, 558-569.
- [61] Gantenbein, G., Borie, E., Möbius, A., Piosczyk, B., Thumm, M., 1991, Design of a high-power 140 GHz gyrotron oscillator operating in an asymmetric volume mode at KfK. Conf. Digest 16th Int. Conf. on Infrared and Millimeter Waves, Lausanne, Proc., SPIE **1576**, 264-265.
- Piosczyk, B., Kuntze, M., Borie, E., Dammertz, G., Dumbrajs, O., Gantenbein, G., Möbius, A., Nickel H.-U., Thumm, M., 1992, Development of high power 140 GHz gyrotrons at KfK for applications in fusion. Fusion Technology **1992**, eds. C. Ferro, M. Gasparotto, H. Knoepfel. Elsevier Science Publishers B.V., 1993, 618-622.

- [62] Gantenbein, G., Borie, E., Dumbrajs, O., Thumm, M., 1995, Design of a high order volume mode cavity for a 1 MW/140 GHz gyrotron. *Int. J. Electronics*, **78**, 771-782.
- [63] Dammertz, G., Braz, O., Iatrou, C.T., Kuntze, M., Möbius, A., Piosczyk, B., Thumm, M., 1996, Long-pulse operation of a 0.5 MW TE_{10,4} gyrotron at 140 GHz. *IEEE Trans. on Plasma Science*, **24**, 570-578.
- [64] Piosczyk, B., Iatrou, C.T., Dammertz, G., Thumm, M., 1996, Single-stage depressed collectors for gyrotrons, *IEEE Trans. on Plasma Science*, **24**, 579-585.
- [65] Myasnikov, V.E., Cayer, A.P., Bogdanov, S.D., Kurbatov, V.I., 1991, Soviet industrial gyrotrons. *Conf. Digest 16th Int. Conf. on Infrared and Millimeter Waves, Lausanne, SPIE 1576*, 127-128.
- [66] Flyagin, V.A., Goldenberg, A.L., Zapevalov, V.E., 1993, State of the art of gyrotron investigation in Russia. *Conf. Digest 18th Int. Conf. on Infrared and Millimeter Waves, Colchester (Essex, UK), Proc., SPIE 2104*, 581-584.
Denisov, G.G., Flyagin, V.A., Goldenberg, A.L., Khizhnyak, V.I., Kuftin, A.N., Malygin, V.I., Pavelyev, A.B., Pylin, A.V., Zapevalov, V.E., 1991, Investigation of gyrotrons in IAP. *Conf. Digest 16th Int. Conf. on Infrared and Millimeter Waves, Lausanne, SPIE 1576*, 632-635.
- [67] Agapova, M.V., Axenova, L.A., Alikae, V.V., Cayer, A.P., Denisov, G.G., Flyagin, V.A., Fix, A.Sh., Iljin, V.I., Ilyin, V.N., Khmara, V.A., Kostyna, A.N., Kuftin, A.N., Mjasnikov, V.E., Popov, L.G., Zapevalov, V.E., 1994, Long-pulsed 140 GHz/0.5 MW gyrotron: problems and results. *Conf. Digest 19th Int. Conf. on Infrared and Millimeter Waves, Sendai, JSAP Catalog No.: AP 941228*, 79-80.
- [68] Mjasnikov, V.E., Agapova, M.V., Alikae, V.V., Borshchegovsky, A.S., Denisov, G.G., Flyagin, V.A., Fix, A.Sh., Ilyin, V.I., Ilyin, V.N., Keyer, A.P., Khmara, V.A., Khmara, D.V., Kostyna, A.N., Nichiporenko, V.O., Popov, L.G., Zapevalov, V.E., 1996, Megawatt power long-pulse 140 GHz gyrotron. *Proc. 21st Int. Conf. on Infrared and Millimeter Waves, Berlin, AT1*.
- [69] Sakamoto, K., Kasugai, A., Tsuneoka, M., Takahashi, K., Imai, T., Kariya, T., Okazaki, Y., Hayashi, K., Mitsunaka, Y., Hirata, Y., 1995, Development of 170 GHz gyrotron for ITER, *Conf. Digest 20th Int. Conf. on Infrared and Millimeter Waves, Lake Buena Vista (Orlando), Florida*, 269-270.
- [70] Sakamoto, K., Kasugai, A., Tsuneoka, M., Takahashi, K., Imai, T., Kariya, T., Okazaki, Y., Hayashi, K., Mitsunaka, Y., Hirata, Y., 1996, Development of 170 GHz high power long pulse gyrotron for ITER. *Proc. 21st Int. Conf. on Infrared and Millimeter Waves, Berlin, AT1*.
- [71] Sakamoto, K., Kasugai, A., Takahashi, K., Tsuneoka, M., Imai, T., Kariya, T., Hayashi, K., 1996, Stable, single-mode oscillation with high-order volume mode at 1 MW, 170 GHz gyrotron. *J. of Physical Society of Japan*, **65**, 1888-1890.
- [72] Grimm, T.L., Kreisler, K.E., Guss, W.C., Temkin, R.J., 1992, Experimental study of a megawatt 200-300 GHz gyrotron oscillator. *Fusion Technology*, **21**, 1648-1657 and, 1993, *Phys. Fluids*, **B5**, 4135-4143.
- [73] Vlasov, S.N., Zagryadskaya, L.I., Orlova, I.M., 1976, Open coaxial resonators for gyrotrons. *Radio Eng. Electron. Phys.*, **21**, 96-102.
- [74] Flyagin, V.A., Khishnyak, V.I., Manuilov, V.N., Pavelyev, A.B., Pavelyev, V.G., Piosczyk, B., Dammertz, G., Höchtl, O., Iatrou, C., Kern, S., Nickel, H.-U., Thumm, M., Wien, A., Dumbrajs, O., 1994, Development of a 1.5 MW coaxial gyrotron at 140 GHz. *Conf. Digest 19th Int. Conf. on Infrared and Millimeter Waves, Sendai, JSAP Catalog No.: AP 941228*, 75-76.

- [75] Piosczyk, B., Braz, O., Dammertz, G., Iatrou, C.T., Kern, S., Möbius, A., Thumm, M., Wien, A., Zhang, S.C., Flyagin, V.A., Khishnyak, V.I., Kuftin, A.N., Manuilov, V.N., Pavelyev, A.B., Pavelyev, V.G., Postnikova, A.N., Zapevalov, V.E., 1995, Development of a 1.5 MW, 140 GHz coaxial gyrotron. Conf. Digest 20th Int. Conf. on Infrared and Millimeter Waves, Lake Buena Vista (Orlando), Florida, 423-424.
- [76] Piosczyk, B., Braz, O., Dammertz, G., Iatrou, C.T., Kern, S., Kuntze, M., Möbius, A., Thumm, M., Flyagin, V.A., Khishnyak, V.I., Kuftin, A.N., Malygin, V.I., Pavelyev, A.B., Zapevalov, V.E., 1996, A 140 GHz, 1.5 MW, $TE_{28,16}$ -coaxial cavity gyrotron. Proc. 21st Int. Conf. on Infrared and Millimeter Waves, Berlin, AM2.
- [77] Iatrou, C.T., Braz, O., Dammertz, G., Kern, S., Kuntze, M., Piosczyk, B., Thumm, M., 1996, Operation of a megawatt coaxial gyrotron at 165 GHz. Proc. 21st Int. Conf. on Infrared and Millimeter Waves, Berlin, ATh15.
- [78] Gaponov, A.V., Flyagin, V.A., Goldenberg, A.L., Nusinovich, G.S., Tsimring, Sh.E., Usov, V.G., Vlasov, S.N., 1981, Powerful millimeter-wave gyrotrons. Int. J. Electronics, **51**, 277-302.
- [79] Hogge, J.P., Kreischer, K.E., Read, M.E., 1995, Results of testing a 3 MW, 140 GHz gyrotron with a coaxial cavity. Conf. Digest 20th Int. Conf. on Infrared and Millimeter Waves, Lake Buena Vista (Orlando), Florida, 417-418.
- [80] Kimura, T., Hogge, J.P., Advani, R., Denison, D., Kreischer, K.E., Temkin, R.J., 1996, Investigation of megawatt power level gyrotrons for ITER. Proc. 21st Int. Conf. on Infrared and Millimeter Waves, Berlin, AM1.
- [81] Xu, K. Y., Kreischer, K.E., Guss, W.C., Grimm, T.L., Temkin, R.J., 1990, Efficient operation of a megawatt gyrotron. Conf. Digest 15th Int. Conf. on Infrared and Millimeter Waves, Orlando, Proc., SPIE **1514**, 324-326.
- [82] Carmel, Y., Chu, K.R., Dialetis, D., Fliflet, A., Read, M.E., Kim, K.J., Arfin, B., Granatstein, V.L., 1982, Mode competition, suppression, and efficiency enhancement in overmoded gyrotron oscillators. Int. J. on Infrared and Millimeter Waves, **3**, 645-665.
- [83] Zapevalov, V.E., Malygin, S.A., Pavelyev, V.G., Tsimring, Sh.E., 1984, Coupled resonator gyrotrons with mode conversion. Radiophys. Quantum Electron., **27**, 846-852.
- [84] Dumbrajs, O., Nusinovich, G.S., 1992, Theory of a frequency-step-tunable gyrotron for optimum plasma ECRH. IEEE Trans. Plasma Science, **20**, 452-457.
- [85] Dumbrajs, O., Thumm, M., Pretterebner, J., Wagner, D., 1992, A cavity with reduced mode conversion for gyrotrons. Int. J. Infrared and Millimeter Waves, **13**, 825-840.
- [86] Denisov, G.G., Kuftin, A.N., Malygin, V.I., Venediktov, N.P., Vinogradov, D.V., Zapevalov, V.E., 1992, 110 GHz gyrotron with a built-in high-efficiency converter. Int. J. Electronics, **72**, 1079-1091.
- [87] Zapevalov, V.E., 1996, Achievement of stable operation of powerful gyrotrons for fusion. 3rd Int. Workshop on Strong Microwaves in Plasmas, Nizhny Novgorod, Russia, Paper S33.
- [88] Bogdanov, S.D., Kurbatov, V.I., Malygin, S.A., Orlov, V.B., Solujanova, E.A., Tai, E.M., 1996, Status of gyrotron development in Nizhny Novgorod Division of Gycom. 3rd Int. Workshop on Strong Microwaves in Plasmas, Nizhny Novgorod, Russia, Paper S35.
- [89] Hargreaves, T.A., Fliflet, A.W., Fischer, R.P., Barsanti, M.L., 1990, Depressed collector performance on the NRL quasi-optical gyrotron. Conf. Digest 15th Int. Conf on Infrared and Millimeter Waves, Orlando, Proc., SPIE **1514**, 330-332.
- [90] Häfner, H.E., Bojarsky, E., Norajitra, P., Reiser, 1992, H. Cryocooled windows for high frequency plasma heating. Fusion Technology 1992, eds. C. Ferro, M. Gasparotto, H. Knoepfel (Elsevier Science Publishers B.V. 1992), pp.520-523.
- [91] Häfner, H.E., Bojarsky, E., Heckert, K., Norajitra, P., Reiser, H., 1994, Liquid nitrogen cooled window for high frequency plasma heating. Journal of Nuclear Materials, **212-215**, 1035-1038.

- [92] Häfner, H.E., Heckert, K., Norajitra, P., Vouriot, R., Hofmann, A., Münch, N., Nickel, H.-U., Thumm, M., Erckmann, V., 1994, Investigations of liquid nitrogen cooled windows for high power millimeter wave transmission. Conf. Digest 19th Int. Conf. on Infrared and Millimeter Waves, Sendai, JSAP Catalog No.: AP 941228, 281-282.
- [93] Heidinger, R., Link, G., 1995, The mm-wave absorption in sapphire and its description by the 2-phonon model. Conf. Digest 20th Int. Conf. on Infrared and Millimeter Waves, Lake Buena Vista (Orlando), Florida, 16-17.
- [94] Norajitra, P., Häfner, H.E., Thumm, M., 1995, Alternatives for edge cooled single disk windows with 1 MW transmission power. Conf. Digest 20th Int. Conf. on Infrared and Millimeter Waves, Lake Buena Vista (Orlando), Florida, 475-476.
- [95] Saitoh, Y., Itoh, K., Yoshiyuki, T., Ebisawa, K., Yokokura, K., Nagashima, T., Yamamoto, T., 1992, Cryogenic window for millimeter-wave transmission. Fusion Technology 1992, eds. C. Ferro, M. Gasparotto, H. Knoepfel (Elsevier Science Publishers B.V. 1992), pp. 632-636.
- [96] Kasugai, A., Yokokura, K., Sakamoto, K., Tsuneoka, M., Yamamoto, T., Imai, T., Saito, Y., Ito, K., Yoshiyuki, T., Ebisawa, K., 1994, High power tests of the cryogenic window for millimeter wave. Conf. Digest 19th Int. Conf. on Infrared and Millimeter Waves, Sendai, JSAP Catalog No.: AP 941228, 295-296.
- [97] Garin, P., Bon-Mardion, G., Pain, M., Heidinger, R., Thumm, M., Dubrovin, A., Giguet, E., Tran, C., 1995, Cryogenically cooled window: a new step toward gyrotron CW operation. Conf. Digest 20th Int. Conf. on Infrared and Millimeter Waves, Lake Buena Vista (Orlando), Florida, 271-272.
- [98] Fix, A.S., Sushilin, P.B., 1993, Calculation and experimental investigation of cryogenic window. Proc. 5th Russian-German Meeting on ECRH and Gyrotrons, Karlsruhe, pp. 389-392 and, 1994, Proc. 6th Russian-German Meeting on ECRH and Gyrotrons, Moscow, 1994, Vol. 2, pp. 244-247.
- [99] Moeller, C.P., Doane, J.L., DiMartino, M., 1994, A vacuum window for a 1 MW CW 110 GHz gyrotron. Conf. Digest 19th Int. Conf. on Infrared and Millimeter Waves, Sendai, Conf. Digest 19th Int. Conf. on Infrared and Millimeter Waves, Sendai, JSAP Catalog No.: AP 941228, 279-280.
- [100] Felch, K., Borchard, P., Cahalan, P., Chu, T.S., Jory, H., Loring Jr., C.M., Moeller, C.P., 1996, Status of 1 MW CW gyrotron development at CPI. Proc. 21st Int. Conf. on Infrared and Millimeter Waves, Berlin, AM16.
- [101] Heidinger, R., 1994, Dielectric property measurements on CVD diamond grades for advanced gyrotron windows. Conf. Digest 19th Int. Conf. on Infrared and Millimeter Waves, Sendai, JSAP Catalog No.: AP 941228, 277-278.
Parshin, V.V., Heidinger, R., Andreev, B.A., Gusev, A.V., Shmagin, V.B., 1995, Silicon with extra low losses for megawatt output gyrotron windows. Conf. Digest 20th Int. Conf. on Infrared and Millimeter Waves, Lake Buena Vista (Orlando), Florida, 22-23.
- [102] Shimozuma, T., Sato, M., Takita, Y., Kubo, S., Idei, H., Ohkubo, K., Watari, T., Morimoto, S., Tajima, K., 1995, Development of elongated vacuum windows for high power CW millimeter waves. Conf. Digest 20th Int. Conf. on Infrared and Millimeter Waves, Lake Buena Vista (Orlando), Florida, 273-274.
- [103] Petelin, M.I., Kasperek, W., 1991, Surface corrugation for broadband matching of windows in powerful microwave generators. Int. J. Electronics, 71, 871-873.

- [104]Nickel, H.-U., Ambrosy, U., Thumm, M., 1992, Vacuum windows for frequency-tunable high-power millimeter wave systems. Conf. Digest 17th Int. Conf. on Infrared and Millimeter Waves, Pasadena, Proc., SPIE **1929**, 462-463.
 Nickel, H.-U., Massler, H., Thumm, M., 1993, Development of broadband vacuum windows for high-power millimeter wave systems. Conf. Digest 18th Int. Conf. on Infrared and Millimeter Waves, Colchester (Essex, UK), Proc., SPIE **2104**, 172-173.
 Shang, C.C., Caplan, M., Nickel, H.-U., Thumm, M., 1993, Electrical analysis of wideband and distributed windows using time-dependent field codes. Conf. Digest 18th Int. Conf. on Infrared and Millimeter Waves, Colchester (Essex, UK), Proc., SPIE **2104**, 178-179.
- [105]Kreischer, K.E., Grimm, T.L., Guss, W.C., Temkin, R.J., Xu, K.Y., 1990, Research at MIT on high frequency gyrotrons for ECRH. Proc. Int. Workshop on Strong Microwaves in Plasmas, Suzdal, Inst. of Applied Physics, Nizhny Novgorod, 1991, 713-725.
- [106]Grimm, T.L., Borchard, P.M., Kreischer, K.E., Guss, W.C., Temkin, R.J., 1992, High power operation of a 200-300 GHz gyrotron oscillator and multimewatt gyrotrons for ITER. Conf. Digest 17th Int. Conf. on Infrared and Millimeter Waves, Pasadena, Proc., SPIE **1929**, 190-191 and 194-195.
 Kimura, T., Danly, B.G., Kreischer, K.E., Temkin, R.J., 1995, Development of a 1 MW, 170 GHz gyrotron with internal mode converter. Conf. Digest 20th Int. Conf. on Infrared and Millimeter Waves, Lake Buena Vista (Orlando), Florida, 201-202.
- [107]Zaytsev, N.I., Pankratova, T.P., Petelin, M.I., Flyagin, V.A., 1974, Millimeter- and submillimeter-wave gyrotrons. Radio Eng. and Electronic Phys., **19**, 103-107.
- [108]Idehara, T., Tatsukawa, T., Ogawa, I., Tanabe, H., Mori, T., Wada, S., Brand, G.F., Brennan, M.H., 1992, Development of a second cyclotron harmonic gyrotron operating at submillimeter wavelengths. Phys. Fluids **B4**, 267-273 and 1993, Phys. Fluids **B5**, 1377-1379.
- [109]Shimizu, Y., Makino, S., Ichikawa, K., Kanemaki, T., Tatsukawa, T., Idehara, T., Ogawa, I., 1995, Development of submillimeter wave gyrotron using 12 T superconducting magnet. Phys. Plasmas, **2**, 2110-2116.
- [110]Idehara, T., Shimizu, Y., Ichikawa, K., Makino, S., Shibutani, K., Kurahashi, K., Tatsukawa, T., Ogawa, I., Okazaki, Y., Okamoto, T., 1995, Development of a medium power, submillimeter wave gyrotron using a 17 T superconducting magnet. Phys. Plasmas, **2**, 3246-3248.
- [111]Idehara, T., Tatsukawa, T., Ogawa, I., Shimizu, Y., Kurahashi, K., Nishida, N., Yoshida, K., 1996, Development of terahertz gyrotron using a 17T superconducting magnet. Proc. 21st Int. Conf. on Infrared and Millimeter Waves, Berlin, AT9.
- [112]Brand, G.F., Fekete, P.W., Hong, K., Moore, K.J., Idehara, T., 1990, Operation of a tunable gyrotron at the second harmonic of the electron cyclotron frequency. Int. J. Electronics, **68**, 1099-1111.
- [113]Hong, K.D., Brand, G.F., 1993, A 150-600 GHz step-tunable gyrotron. J. Appl. Phys., **74**, 5250-5258.
- [114]Spira-Hakkarainen, S.E., Kreischer, K.E., Temkin, R.J., 1990, Submillimeter-wave harmonic gyrotron experiment. IEEE Trans. Plasma Science, **18**, 334-342.
- [115]Geist, T., Thumm, M., Wiesbeck, W., 1991, Linewidth measurement on a 140 GHz gyrotron. Conf. Digest 16th Int. Conf. on Infrared and Millimeter Waves, Lausanne, Proc., SPIE **1576**, 272-273.
- [116]Antakov, I.I., Gachev, I.G., Kurbatov, V.I., Sokolov, E.V., Solujanova, E.A., Zasytkin, E.V., 1996, A Ka-band 10 kW CW efficient compact gyrotron for materials processing. Proc. 21st Int. Conf. on Infrared and Millimeter Waves, Berlin, AM3.
- [117]Möbius, A., 1995, A permanent magnet system for gyrotrons, 1995, Conf. Digest 20th Int. Conf. on Infrared and Millimeter Waves, Lake Buena Vista (Orlando), Florida, and Millimeter Waves, Lake Buena Vista (Orlando), Florida, 487-488.

- [118]Kikunaga, T., Asano, H., Hemmi, K., Sato, F., Tsukamoto, T., 1995, A 28 GHz gyrotron with a permanent magnet system. Conf. Digest 20th Int. Conf. on Infrared and Millimeter Waves, Lake Buena Vista (Orlando), Florida, 485-486.
- [119]Takada, T., Ohashi, K., Honshima, M., Kikunaga, T., 1995, Nd-Te-B permanent magnet circuit for a 28 GHz CW gyrotron. Conf. Digest 20th Int. Conf. on Infrared and Millimeter Waves, Lake Buena Vista (Orlando), Florida, and Millimeter Waves, Lake Buena Vista (Orlando), Florida, 489-490.
- [120]Asano, H., Kikunaga, K., Hemmi, K., Sato, F., Tsukamoto, T., 1996, A 28 GHz gyrotron with a permanent magnet system for industry applications. Proc. 21st Int. Conf. on Infrared and Millimeter Waves, Berlin, AM5.
- [121]Bratman, V.L., Ginzburg, N.S., Nusinovich, G.S., Petelin, M.I., Strelkov, P.S., 1981, Relativistic gyrotrons and cyclotron autoresonance masers. Int. J. Electronics, **51**, 541-567.
- [122]Granatstein, V.L., Herndon, M., Sprangle, P., Carmel, Y., Nation, J.A., 1975, Gigawatt microwave emission from an intense relativistic electron beam. Plasma Physics, **17**, 23-28.
- [123]Didenko, A.N., Zherlitsyn, A.G., Zelentsov, V.I., Sulakshin, A.S., Fomenko, G.P., Shtein, Yu.G., Yushkov, Yu.G., 1976, Generation of gigawatt microwave pulses in the nanosecond range. Sov. J. Plasma Phys., **2**, 283-285.
- [124]Krementsov, V.I., Petelin, M.I., Rabinovich, M.S., Rukhadze, A.A., Strelkov, P.S., Shkvarunets, A.G., 1978, Plasma-filled gyrotron with a relativistic supervacuum electron beam, Sov.Phys. JETP, **48**, 1084.
- [125]Ginzburg, N.S., Kremontsov, V.I., Petelin, M.I., Strelkov, P.S., Shkvarunets, A.G., 1979, Experimental investigation on a high-current relativistic cyclotron maser. Sov. Phys. Tech. Phys., **24**, 218-222.
- [126]Voronkov, S.N., Kremontsov, V.I., Strelkov, P.S., Shkvarunets, A.G., 1982, Stimulated cyclotron radiation and millimeter wavelengths from high-power relativistic electron beams, Sov. Phys. Tech. Phys., **27**, 68-69.
- [127]Bratman, V.L., Denisov, G.G., Ofitserov, M.M., Korovin, S.D., Polevin, S.D., Rostov, V.V., 1987, Millimeter-wave HF relativistic electron oscillators. IEEE Trans. on Plasma Science, **15**, 2-15.
- [128]Gold, S.H., Fliflet, A.W., Manheimer, W.M., McCowan, R.B., Lee, R.C., Granatstein, V.L., Hardesty, D.L., Kinkead, A.K., Sucey, M., 1988, High peak power Ka-band gyrotron oscillator experiments with slotted and unslotted cavities, IEEE, Trans. Plasma Science, **16**, 142.
- [129]Black, W.M., Gold, S.H., Fliflet, A.W., Kirkpatrick, D.A., Manheimer, W.M., Lee, R.C., Granatstein, V.L., Hardesty, D.L., Kinkead, A.K., Sucey, M., 1990, Megavolt Multikiloamp Ka-band gyrotron oscillator experiment. Phys. Fluids, **B2**, 193.
- [130]Cross, A.W., Spark, S.N., Phelps, A.D.R., 1988, Gyrotron experiments using cavities of different ohmic Q. Conf. Digest 17th Int. Conf. on Infrared and Millimeter Waves, Pasadena, Proc., SPIE **1929**, 392-393.
Cross, A.W., Spark, S.N., Phelps, A.D.R., 1995, Gyrotron experiments using cavities of different ohmic Q. Int. J. Electronics, **79**, 481-493.
Cross, A.W., MacGregor, S.J., Phelps, A.D.R., Ronald, K., Spark, S.N., Turnbull, S.M., 1995, Megawatt, 1 kHz PRF tunable gyrtron experiments. Conf. Digest 20th Int. Conf. on Infrared and Millimeter Waves, Lake Buena Vista (Orlando), Florida, 530-531.
- [131]Gilgenbach, R.M., Wang, J.G., Choi, J.J., Outten, C.A., Spencer, T.A., 1988, Intense electron beam cyclotron masers with microsecond pulse lengths. Conf. Digest 13th Int. Conf. on Infrared and Millimeter Waves, Honolulu, Hawaii, Proc., SPIE **1039**, 362-363.
Gilgenbach, R.M., Hochman, J.M., Jaynes, R. Walter, M.T., Rintamaki, J., Lash, J.S., Luginsland, J., Lau, Y.Y., Spencer, T.A., 1995, Rectangular interaction structures in high power gyrotron devices. Conf. Digest 20th Int. Conf. on Infrared and Millimeter Waves, Lake Buena Vista (Orlando), Florida, 528-529.

- [132]Bratman, V.L., 1996, Cyclotron autoresonance masers and relativistic gyrotrons, 3rd Workshop on Strong Microwaves in Plasmas, Nizhny Novgorod, Russia, Paper S1.
- [133]Fliflet, A.W., Hargreaves, T.A., Fischer, R.P., Manheimer, W.M., Sprangle, P., 1990, Review of quasi-optical gyrotron development. *J. Fusion Energy*, **9**, 31-58.
Fischer, R.P., Fliflet, A.W., Manheimer, W.M., Levush, B., Antonsen Jr., T.M., 1993, Mode priming an 85 GHz quasioptical gyrokystron. *Conf. Digest 18th Int. Conf. on Infrared and Millimeter Waves, Colchester (Essex, UK), Proc., SPIE 2104*, 330-331.
- [134]Gapochka, M.G., Korolev, A.F., Kostienko, A.I., Sukhorukov, A.P., Sheludchenkov, A.V., Golenitski, I.I., Evtushenko, O.V., Pulino, A., 1996, Compact low-voltage quasioptical millimeter-wave generators. *Proc. 25th European Microwave Conference, Prague*, 144-145.
- [135]Hogge, J.P., Cao, H., Kasperek, W., Tran, T.M., Tran, M.Q., Paris, P.J., 1991, Ellipsoidal diffraction grating as output coupler for quasi-optical gyrotrons. *Conf. Digest 16th Int. Conf. on Infrared and Millimeter Waves, Lausanne, Proc., SPIE 1576*, 540-541.
- [136]Bratman, V.L., Denisov, G.G., 1992, Cyclotron autoresonance masers - recent experiments and prospects. *Int. J. Electronics*, **72**, 969-981.
- [137]Bratman, V.L., Denisov, G.G., Ofitserov, M.M., Samsonov, S.V., Arkhipov, O.V., Kazacha, V.I., Krasnykh, A.K., Perelstein, E.A., Zamrij, A.V., 1992, Cyclotron autoresonance maser with high Doppler frequency up-conversion. *Int. J. Infrared and Millimeter Waves*, **13**, 1857-1873.
- [138]Bratman, V.L., Denisov, G.G., Samsonov, S.V., 1993, Cyclotron autoresonance masers: achievements and prospects of advance to the submillimeter wavelength range. *Proc. 2nd Int. Workshop on Strong Microwaves in Plasmas, Moscow - Nizhny Novgorod -Moscow, Inst. of Applied Physics, Nizhny Novgorod, 1994, Vol. 2*, 690-711.
- [139]Bratman, V.L., Denisov, G.G., Kol'chugin, B.D., Samsonov, S.V., Volkov, A.B., 1995, Experimental demonstration of high-efficiency cyclotron-autoresonance-maser operation. *Phys. Rev. Lett.*, **75**, 3102-3105.
- [140]Caplan, M., Kulke, B., Westenskow, G.A.; McDermott, D.B., Luhmann, Jr., N.C., 1992, Induction-linac-driven, millimeter-wave CARM oscillator. *Laboratory Report UCRL-53689-80*, Lawrence Livermore National Laboratory, Livermore, California.
- [141]Danly, B.G., Hartemann, F.V., Chu, T.S., Legorburn, P., Menninger, W.L., Temkin, R.J., 1992, Long-pulse millimeter-wave free-electron laser and cyclotron autoresonance maser experiments. *Phys. Fluids*, **B4**, 2307-2314.
- [142]Alberti, S., Danly, B.G., Gulotta, G., Giguët, E., Kimura, T., Menninger, W.L., Rullier, J.L., Temkin, R.J., 1993, Experimental study of a 28 GHz high-power long-pulse cyclotron autoresonance maser oscillator. *Phys. Rev. Lett.*, **71**, 2018-2021.
- [143]Wang, J.G., Gilgenbach, R.M., Choi, J.J., Outten, C.A., Spencer, T.A., 1989, Frequency-tunable, high-power microwave emission from cyclotron autoresonance maser oscillation and gyrotron interactions. *IEEE Trans. Plasma Science*, **17**, 906-908.
Choi, J.J., Gilgenbach, R.M., Spencer, T.A., 1992, Mode competition in Bragg resonator cyclotron resonance maser experiments driven by a microsecond intense electron beam. *Int. J. Electronics*, **72**, 1045-1066.
- [144]Cooke, S.J., Cross, A.W., He, W., Phelps, A.D.R., 1995, The operation of a second harmonic CARM oscillator. *Conf. Digest 20th Int. Conf. on Infrared and Millimeter Waves, Lake Buena Vista (Orlando), Florida*, 427-428.
Cooke, S.J., Cross, A.W., He, W., Phelps, A.D.R., 1996, Experimental operation of a cyclotron autoresonance maser oscillator at the second harmonic. *Phys. Rev. Lett.*, **77**, 4836-4839.
- [145]Burke, J.M., Czarnaski, M.A., Fischer, R.P., Giangrave, M., Fliflet, A.W., Manheimer, W.M., 1991, 85 GHz TE₁₃ phase-locked gyrokystron oscillator experiment. *Conf. Digest 13th Int. Conf. on Infrared and Millimeter Waves, Honolulu, Hawaii, Proc., SPIE 1039*, 228-229.

- [146]Fischer, R.P., Fliflet, A.W., Manheimer, W.M., 1992, The NRL 85 GHz quasioptical gyrokystron experiment. Conf. Digest 17th Int. Conf. on Infrared and Millimeter Waves, Pasadena, Proc., SPIE **1039**, 254-255.
- [147]Antakov, I.I., Aksenova, L.A., Zasytkin, E.V., Moiseev, M.A., Popov, L.G., Sokolov, E.V., Yulpatov, V.K., 1990, Multicavity phase-locked gyrotrons for lower-hybrid heating in toroidal plasmas. Proc. Int. Workshop on Strong Microwaves in Plasmas, Suzdal, Inst. of Applied Physics, Nizhny Novgorod, 1991, 773-782.
- [148]Antakov, I.I., Moiseev, M.A., Sokolov, E.V., Zasytkin, E.V., 1993, Theoretical and experimental investigation of X-band two-cavity gyrokystron. Conf. Digest 18th Int. Conf. on Infrared and Millimeter Waves, Colchester (Essex, UK), Proc., SPIE **2104**, 336-337.
- [149]Antakov, I.I., Zasytkin, E.V., Sokolov, E.V., Yulpatov, V.K., Keyer, A.P., Musatov, V.S., Myasnikov, V.E., 1993, 35 GHz radar gyrokystrons. Conf. Digest 18th Int. Conf. on Infrared and Millimeter Waves, Colchester (Essex, UK), Proc., SPIE **2104**, 338-339.
- [150]Antakov, I.I., Gaponov, A.V., Zasytkin, E.V., Sokolov, E.V., Yulpatov, V.K., Aksenova, L.A., Keyer, A.P., Musatov, V.S., Myasnikov, V.E., Popov, L.G., Levitan, B.A., Tolkachev, A.A., 1993, Gyrokystrons: millimeter wave amplifiers of the highest power. Proc. 2nd Int. Workshop on Strong Microwaves in Plasmas, Moscow - Nizhny Novgorod - Moscow, ed. A.G. Litvak, Inst. of Applied Physics, Nizhny Novgorod, 1994, **Vol. 2**, 587-596.
- [151]Antakov, I.I., Moiseev, M.A., Sokolov, E.V., Zasytkin, E.V., 1994, Theoretical and experimental investigation of X-band two-cavity gyrokystron. Int. J. of Infrared and Millimeter Waves, **15**, 873-887.
- [152]Zasytkin, E.V., Moiseev, M.A., Sokolov, E.V., Yulpatov, V.K., 1995, Effect of penultimate cavity position and tuning on three-cavity gyrokystron amplifier performance. Int. J. Electronics, **78**, 423-433.
- [153]Zasytkin, E.V., Moiseev, M.A., Gachev, I.G., Antakov, I.I., 1996, Study of high-power Ka-band second-harmonic gyrokystron amplifier. IEEE Trans. on Plasma Science, **24**, 666-670.
- [154]Antakov, I.I., Gachev, I.G., Sokolov, E.V., 1995, Experimental study of two-cavity gyrotron with feedback between cavities. Proc. Conf.: Intense Microwave-Pulses III, San Diego, Proc. SPIE **2557**, 380-385.
- [155]Antakov, I.I., Zasytkin, E.V., Sokolov, E.V., 1993, Design and performance of 94 GHz high power multicavity gyrokystron amplifier. Conf. Digest 18th Int. Conf. on Infrared and Millimeter Waves, Colchester (Essex, UK), Proc., SPIE **2104**, 466-467 and Proc. 2nd Int. Workshop on Strong Microwaves in Plasmas, Moscow - Nizhny Novgorod - Moscow, ed. A.G. Litvak, Inst. of Applied Physics, Nizhny Novgorod, 1994, **Vol. 2**, 754-758.
- [156]Tantawi, S.G., Main, W.T., Latham, P.E., Nusinovich, G.S., Lawson, W.G., Striffler, C.D., Granatstein, V.L., 1992, High-power X-band amplification from an overmoded three-cavity gyrokystron with a tunable penultimate cavity. IEEE Trans. Plasma Science, **20**, 205-215.
- [157]Lawson, W., Calame, J.P., Hogan, P., Skopec, M., Striffler, C.D., Granatstein, V.L., 1992, Performance characteristics of a high-power X-band two-cavity gyrokystron. IEEE Trans. Plasma Science, **20**, 216-223.
- [158]Matthews, H.W., Lawson, W., Calame, J.P., Flaherty, M.K.E., Hogan, B., Cheng, J., Latham, P.E., 1994, Experimental studies of stability and amplification in a two-cavity second harmonic gyrokystron. IEEE Trans. Plasma Science, **22**, 825-833.
- [159]Lawson, W., Hogan, B., Calame, J.P., Cheng, J., Latham, P.E., Granatstein, V.L., 1994, Experimental studies of 30 MW fundamental mode and harmonic gyro-amplifiers. Conf. Digest 19th Int. Conf. on Infrared and Millimeter Waves, Sendai, JSAP Catalog No.: AP 941228, 421-422.
- [160]Park, G.-S., Granatstein, V.L., Park, S.Y., Armstrong, C.M., Ganguly, A.K., 1992, Experimental study of efficiency optimization in a three-cavity gyrokystron amplifier. IEEE Trans. on Plasma Science, **20**, 224-231.

- [161] Lawson, W., Hogan, B., Flaherty, M.K.E., Metz, H., 1996, Design and operation of a two-cavity third harmonic Ka-band gyrokystron, *Appl. Phys. Lett.*, **63**, 1849-1851.
- [162] Barsanti, M.L., Smutek, L.S., Armstrong, C.M., Malonf, P.M., 1995, Investigation of noise characteristics of gyro-amplifiers. *Conf. Digest 20th Int. Conf. on Infrared and Millimeter Waves*, Lake Buena Vista (Orlando), Florida, 349 and Blank, M., 1996, private communication, NRL, Washington, D.C..
- [163] Zasyupkin, E.V., 1996, private communication, IAP Nizhny Novgorod and Seminar Talk at NRL, Washington, D.C..
- [164] Lawson, W., Latham, P.E., Calame, J.P., Cheng, J., Hogan, B., Nusinovich, G.S., Irwin, V., Granatstein, V.L., Reiser, M., 1995, High power operation of first and second harmonic gyrotwystrons. *J. Appl. Phys.*, **78**, 550-559.
- [165] Leou, K.C., McDermott, D.B., Luhmann, Jr., N.C., 1992, Design of experimental dielectric loaded wideband Gyro-TWT. *Conf. Digest 17th Conf. on Infrared and Millimeter Waves*, Pasadena, Proc., SPIE **1929**, 326-327.
- Leou, K.C., Wang, Q.S., Chong, C.K., Balkcum, A.J., Fochs, S.N., Garland, E.S., Pretterebner, J., Lin, A.T., McDermott, D.B., Hartemann, F., Luhmann, Jr., N.C., 1993, Gyro-TWT amplifiers at UCLA, *Conf. Digest 18th Int. Conf. on Infrared and Millimeter Waves*, Colchester (Essex, UK), Proc., SPIE **2104**, 531-532.
- Wang, Q.S., Leou, K.C., Chong, C.K., Balkeum, A.J., McDermott, D.B., Luhmann, Jr., N.C., 1994, Gyro-TWT amplifier development at UCD, *Conf. Digest 19th Int. Conf. on Infrared and Millimeter Waves*, Sendai, JSAP Catalog No.: AP 941228, 415-416.
- Wang, Q.S., McDermott, D.B. Luhmann, Jr., N.C., 1995, Stable operation of a 200 kW second harmonic TE_{21} gyro-TWT amplifier. *Conf. Digest 20th Int. Conf. on Infrared and Millimeter Waves*, Lake Buena Vista (Orlando), Florida, 347-348.
- [166] Wang, Q.S., McDermott, D.B. Luhmann, Jr., N.C., 1995, Demonstration of marginal stability by a 200 kW second-harmonic gyro-TWT amplifier. *Phys. Rev. Lett.* **75**, 4322-4325.
- [167] Wang, Q.S., McDermott, D.B., Luhmann, Jr., N.C., 1996, Operation of a stable 200-kW second-harmonic gyro-TWT amplifier. *IEEE Trans. on Plasma Science*, **24**, 700-706.
- [168] Leou, K.C., McDermott, D.B., Luhmann, Jr., N.C., 1996, Large-signal characteristics of a wide-band dielectric-loaded gyro-TWT amplifier. *IEEE Trans. on Plasma Science*, **24**, 718-726.
- [169] Furano, D.S., McDermott, D.B., Kou, C.S., Luhman, Jr., N.C., Vitello, P., 1989, Theoretical and experimental investigation of a high-harmonic gyro-TWT amplifier, *Phys. Rev. Lett.*, **62**, 1314-1317.
- [170] Chu, K.R., Barnett, L.R., Lau, W.K., Chang, L.H., Chen H.Y., 1990, A wide-band millimeter-wave gyrotron traveling-wave amplifier experiment. *IEEE Trans. Electron Devices*, **37**, 1557-1560.
- [171] Chu, K.R., Barnett, L.R., Chen, H.Y., Chen, S.H., Wang, CH., Yeh, Y.S., Tsai, Y.C., Yang, T.T., Dawn, T.Y., 1995, Stabilization of absolute instabilities in the gyrotron traveling wave amplifier. *Phys. Rev. Lett.*, **74**, 1103-1106.
- [172] Park, G.S., Park, S.Y., Kyser, R.H., Armstrong, C.M., Ganguly, A.K., Parker, R.K., 1994, Broadband operation of a Ka-band tapered gyro-traveling wave amplifier. *IEEE Trans. Plasma Science*, **22**, 536-543.
- [173] Park, G.S., Choi, J.J., Park, S.J., Armstrong, C.M., Ganguly, A.K., Kyser, R.H., Parker, R.K., 1995, Gain broadening of two-stage tapered gyrotron traveling wave tube amplifier, *Phys. Rev. Lett.*, **74**, 2399-2402.
- [174] Choi, J.J., Park, G.S., Ganguly, A.K., Armstrong, C.M., Calise, F., Wood, F., Sobocinski, B., Parker, R.K., 1995, Experimental investigation on broadband millimeter wave gyro-TWT amplifiers. *Conf. Digest 20th Int. Conf. on Infrared and Millimeter Waves*, Lake Buena Vista (Orlando), Florida, 343-344.

- [175]Ferguson, E., Symons, R.S., 1981, A gyro-TWT with a space-charged limited gun. Proc. Int. Electron Device Meeting, 198-201.
- [176]Bohlen, H.P., Felch, K., 1996, private communication, CPI, Palo Alto.
- [177]Menninger, W.L., Danly, B.G., Temkin, R.J., 1996, Multimegawatt relativistic harmonic gyrotron traveling-wave tube amplifier experiments. IEEE Trans. on Plasma Science, **24**, 687-699.
- [178]Gold, S.H., Fliflet, A.W., Kirkpatrick, D.A., 1989, High-power millimeter-wave gyro-traveling-wave amplifier. Conf. Digest 14th Int. Conf. on Infrared and Millimeter Waves, Würzburg, SPIE **1240**, 332-333.
- [179]Park, S.Y., Kyser, R.H., Armstrong, C.M., Parker, R.K., Granatstein, V.L., 1990, Experimental Study of a Ka-band gyrotron backward-wave oscillator. IEEE Trans. on Plasma Science, **18**, 321-325.
- [180]Kou, C.S., Chen, S.H., Barnett, L.R., Chu, K.R., 1993, Experimental study of an injection locked gyrotron backward wave oscillator. Phys. Rev. Lett., **70**, 924-927.
- [181]Basten, M.A., Guss, W.C., Kreisler, K.E., Temkin, R.T., Caplan, M., 1995, Experimental investigation of a 140 GHz gyrotron-backward wave oscillator. Int. J. Infrared and Millimeter Waves, **16**, 880-905.
- [182]Walter, M.T., Gilgenbach, R.M., Menge, P.R., Spencer, T.A., 1994, Effects of tapered tubes on long-pulse microwave emission from intense e-beam gyrotron-backward-wave oscillators. IEEE Trans. Plasma Sciences, **22**, 578-584.
- [183]Walter, M.T., Gilgenbach, R.M., Luginsland, J.W., Hochman, J.M., Rintamaki, J.I., Jaynes, R.L., Lau, Y.Y., Spencer, T.A., 1996, Effects of tapering on gyrotron backward-wave oscillators. IEEE Trans. on Plasma Science, **24**, 636-647.
- [184]Spencer, T.A., Arman, M.J., Hendricks, K.J., Hackett, K.E., Stump, M., Gilgenbach, R.M., 1995, Non-axisymmetric mode competition in a high current, high voltage TE_{01} gyrotron-backward-wave oscillator experiment. Conf. Digest 20th Int. Conf. on Infrared and Millimeter Waves, Lake Buena Vista (Orlando), Florida, 536-537.
- [185]Spencer, T.A., Davis, C.E., Hendricks, K.J., Agee, F.J., Gilgenbach, R.M., 1996, Results from gyrotron backward wave oscillator experiments utilizing a high-current high-voltage annular electron beam. IEEE Trans. on Plasma Science, **24**, 630-635.
- [186]Ono, S., Yamanouchi, K., Shibata, Y., Koike, Y., 1962, Cyclotron fast-wave tube using spatial harmonic interaction- the traveling wave peniotron. Proc. 4th Int. Congress Microwave Tubes, Scheveningen, 355-363.
- [187]Ganguly, A.K., Ahn, S., Park, S.Y., 1988, Three dimensional nonlinear theory of the gyropeniotron amplifier. Int. J. Electronics, **65**, 597-618.
- [188]Ono, S., Tsutaki, K., Kageyama, T., 1984, Proposal of a high efficiency tube for high power millimetre or submillimetre wave generation: The gyro-peniotron. Int. J. Electronics, **56**, 507-519.
- [189]Yokoo, K., Razeghi, M., Sato, N., Ono, S., 1988, High efficiency operation of the modified peniotron using TE_{11} rectangular waveguide cavity. Conf. Digest, 13th Int. Conf. on Infrared and Millimeter Waves, Honolulu, Hawaii, Proc., SPIE **1039**, 135-136
- [190]Yokoo, K., Musyoki, S., Nakazato, Y., Sato, N., Ono, S., 1990, Design and experiments of auto-resonant peniotron oscillator. Conf. Digest 15th Int. Conf on Infrared and Millimeter Waves, Orlando, Proc., SPIE **1514**, 10-12.
- [191]Yokoo, K., Shimawaki, H., Tadano, H., Ishihara, T., Sagae, N., Sato, N., Ono, S., 1992, Design and experiments of higher cyclotron harmonic peniotron oscillators. Conf. Digest 17th Int. Conf. on Infrared and Millimeter Waves, Pasadena, Proc., SPIE **1929**, 498-499.
Musyoki, S., Sagae, K., Yokoo, K., Sato, N., Ono, S., 1992, Experiments on highly efficient operation of the auto-resonant peniotron oscillator. Int. J. Electronics, **72**, 1067-1077.

- [192]Ono, S., Ansai, H., Sato, N., Yokoo, K., Henmi, K., Idehara, T., Tachikawa, T., Okazaki, I., Okamoto, T., 1986, Experimental study of the 3rd harmonic operation of gyro-peniotron at 70 GHz. Conf. Digest 11th Int. Conf. on Infrared and Millimeter Waves, Pisa, 37-39, and Okazaki, Y., 1994, private communication, Toshiba, Nasushiobara, Japan.
- [193]Marshall, T.C., 1985, Free electron lasers, MacMillan, New York.
Sprangle, P., Coffey, T., 1985, New high power coherent radiation sources, in Infrared and Millimeter Waves, Vol. 13, ed. K.J. Button, Academic Press, New York, 19-44.
Freund, H.P., Antonsen, T.M., Jr., 1996, Principles of free-electron lasers. Chapman & Hall, London, 2nd edition.
- [194]Gallerano, G.P., 1994, The free electron laser: state of the art, developments and applications. Nucl. Instr. Meth., **A340**, 11-16.
- [195]Phillips, R.M., 1960, The ubitron, a high-power traveling-wave tube based on a periodic beam interaction in unloaded waveguide., IRE Trans. Electron. Dev., **ED-7**, 231-241 and, 1988, History of the ubitron. Nucl. Instr. Meth., **A272**, 1-9.
- [196]Verhoeven, A.G.A., Bongers, W.A., Best, R.W.B., van Ingen, A.M., Manintveld, P., Urbanus, W.H., van der Wiel, M.J., Bratman, V.L., Denisov, G.G., Shmelyov, M.Yu., Nickel, H.-U., Thumm, M., Müller, G., Kasperek, W., Pretterebner, J., Wagner, D., Caplan, M., 1992, The 1 MW, 200 GHz FOM-Fusion-FEM, Conf. Digest 17th Int. Conf. on Infrared and Millimeter Waves, Pasadena (Los Angeles), Proc., SPIE **1929**, 126-127.
Urbanus, W.H., Best, R.W.B., Bongers, W.A., van Ingen, A.M., Manintveld, P., Sterk, A.B., Verhoeven, A.G.A., van der Wiel, M.J., Caplan, M., Bratman, V.L., Denisov, G.G., Varfolomeev, A.A., Khlebnikov, A.S., 1993, Design of the 1 MW, 200 GHz, FOM fusion FEM, Nucl. Instr. Meth., **A 331**, 235-240.
Verhoeven, A.G.A., Bongers, W.A., van der Geer, C.A.J., Manintveld, P., Schüller, F.C., Urbanus, W.H., Valentini, M., van der Wiel, M.J., 1995, A broad-tuneable free electron maser for ECW applications. Proc. 9th Joint Workshop on Electron Cyclotron Emission and Electron Cyclotron Heating, Borrego Springs, California, 309-320.
- [197]Freund, H.P., Granatstein, V.L., 1995, Longe wavelength free electron laser in 1994. Nucl. Instr. Meth., **A358**, 551-554 and, 1996, Nucl. Instr. Meth. **A375**, 665-668 and, 1997, private communications.
- [198]Bottolier-Curtet, H., Gardelle, J., Bardy, J., Bonnafond, C., Devin, A., Gardent, D., Germain, G., Gouard, Ph., Labrousche, J., Launspach, J., Le Taillandier, P., de Mascureau, J., 1992, Progress in free electron maser experiments at CESTA, Nucl. Instr. Meth., **A318**, 131-134.
Rullier, J.L., Gardelle, J., Labrousche, J., Le Taillandier, P., 1995, Strong coupling operation of a FEL amplifier with an axial magnetic field. Nucl. Instr. Meth., **A358**, 118-121, and 1996, Phys. Rev. E, **53**, 2787-2794.
- [199]Gardelle, J., Labrousche, J., Marchese, G., Rullier, J.L., Villate, D., 1996, Analysis of the beam bunching produced by a free electron laser. Physics of Plasmas, **3**, 4197-4206.
- [200]Dodd, J.W., Marshall, T.C., 1990, Spiking Radiation in the Columbia free electron laser. IEEE Trans. Plasma Science, **18**, 447-450.
Marshall, T.C., Cecere, M.A., 1994, A measurement of space-charge fields in a microwave free electron laser, Physica Scripta, **T52**, 58-60.
Cecere, M., Marshall, T.C., 1994, A free electron laser experiment on angular steering. IEEE Trans. Plasma Science, **22**, 654-658.
- [201]Renz, G. Spindler, G., 1995, Status of the Stuttgart Raman free-electron laser project. Nucl. Instr. Meth., **A358**, ABS13.
- [202]Ciocci, F., Bartolini, R., Doria, A., Gallerano, G.P., Giovenale, E., Kimmitt, M.F., Messina, G., Renieri, A., 1993, Operation of a compact free-electron laser in the millimeter-wave region with a bunched electron beam. Phys. Rev. Lett., **70**, 928-931.

- [203]Hartemann, F., Buzzi, J.M., 1988, Experimental studies of a millimeter-wave free-electron laser. Proc. 7th Int.Conf. on High-Power Particle Beams, Karlsruhe 1988, eds., Bauer, W., Schmidt, W., Vol. II, 1287-1292.
- [204]Bratman, V.L., Denisov, G.G., Ofitserov, M.M., Korovin, S.D., Polevin, S.D., Rostov, V.V., 1987, Millimeter-wave hf relativistic electron oscillators. IEEE Trans. Plasma Science, **15**, 2-15
- [205]Peskov, N.Yu., Bratman, V.L., Ginzburg, N.S., Denisov, G.G., Kolchugin, B.D., Samsonov, S.V., Volkov, A.B., 1996, Experimental study of a high-current FEM with a broadband microwave system. Nucl. Instr. Meth., **A375**, 377-380.
- [206]Bratman, V.L., Denisov, G.G., Ginzburg, N.S., Kol'chugin, B.D., Peskov, N.Y., Samsonov, S.V., Volkov, A.B., 1996, Experimental study of an FEM with a microwave system of a new type. IEEE Trans. on Plasma Science, **24**, 744-749.
- [207]Arzhannikov, A.V., Bobylev, V.B., Sinitsky, S.L., Tarasov, A.V., Ginzburg, N.S., Peskov, N.Yu., 1995, Ribbon-FEL experiments at one-dimension distributed feedback. Nucl. Instr. Meth., **A358**, 112-113.
- [208]Kaminsky, A.K., Kaminsky, A.A., Sarantsev, V.P., Sedykh, S.N., Sergeev, A.P., Ginzburg, N.S., Peskov, N.Yu., Sergeev, A.S., 1996, High efficiency FEL-oscillator with Bragg resonator operated in reversed guide field regime. Nucl. Instr. Meth., **A375**, 215-218.
- [209]Akiba, T., Tanaka, K., Mokuno, M., Miyamoto, S., Mima, K., Nakai, S., Kuruma, S., Imasaki, K., Yamanaka, C., Fukuda, M., Ohigashi, N., Tsunawaki, Y., 1990, Helical distributed feedback free-electron laser. Appl. Phys.Lett., **56**, 503-505.
- [210]Asakawa, M., Sakamoto, N., Inoue, N., Yamamoto, T., Mima, K., Nakia, S., Chen, J., Eujita, M., Imasaki, K., Yamanaka, C., Agari, T., Asakuma, T., Ohigashi, N., Tsunawaki, Y., 1994, Experimental study of a waveguide free-electron laser using the coherent synchrotron radiation emitted from electron bunches, Appl. Phys.Lett. **64**, 1601-1603.
- [211]Mizuno, T., Ootuki, T., Ohshima, T., Saito, H., 1995, Experimental mode analysis of the circular free electron laser. Nucl. Instr. Meth., **A358**, 131-134.
- [212]Sakamoto, K., Kishimoto, Y., Watanabe, A., Kobayashi, T., Musyoki, S., Oda, H., Tokuda, S., Nakamura, Y., Kawasaki, S., Ishizuka, H., Sato, M., Nagashima, T., Shiho, M., 1992, MM wave FEL experiment with focusing wiggler, Course and Workshop on High Power Microwave Generation and Applications. Int. School of Plasma Physics, Varenna, 1991, eds., D. Akulina, E. Sindoni, C. Wharton, Editrice Compositori Bologna, 597-604.
- [213]Sakamoto, K., Kobayashi, T., Kawasaki, S., Kishimoto, Y., Musyoki, S., Watanabe, A., Takahashi, M., Ishizuka, H., Sato, M., Shiho, H., 1994, Millimeter wave amplification in a free electron laser with a focusing wiggler. J. Appl. Phys., **75**, 36-42.
- [214]Lee, B.C., Kim, S.K., Jeong, Y.U., Cho, S.O., Cha, B.H., Lee, J., 1996, First lasing of the KAERI millimeter-wave free electron laser, Nucl. Instr. Meth., **A375**, 28-31.
- [215]Ozaki, T., Ebihara, K., Hiramatsu, S., Kimura, Y., Kishiro, J., Monaka, T., Takayama, K., Whittum, D.H., 1992, First result of the KEK X-band free electron laser in the ion channel guiding regime. Nucl. Instr. Meth., **A318**, 101-104.
- [216]Takayama, K., Kishiro, J., Ebihara, K., Ozaki, T., Hiramatsu, S., Katoh, H., 1994, 1.5 MeV ion-channel guided X-band free-electron laser amplifier. Conf. Digest 19th Int. Conf. on Infrared and Millimeter Waves, Sendai, JSAP Catalog No.: AP 941228, 3-4.
- [217]Takayama, K., Kishiro, J., Ebihara, K., Ozaki, T., Hiramatsu, S., Katoh, H., 1995, Experimental results on the 1.5 MeV ion channel guided X-band free electron laser. Nucl. Instr. Meth., **A358**, 122-125.
- Saito, K., Takayama, K., Ozaki, T., Kishiro, J., Ebihara, K., Hiramatsu, S., 1996, X-band prebunched FEL-amplifier, Nucl. Instr. Meth., **A375**, 237-240.

- [218]Orzechowski, T.J., Anderson, B.R., Clark, J.G., Fawley, W.M., Paul, A.C., Prosnitz, D., Scharlemann, E.T., Yarema, S.M., Hopkins, D.B., Sessler, A.M., Wurtele, J.S., 1986, High-efficiency extraction of microwave radiation from a tapered-wiggler free-electron laser. *Phys. Rev. Lett.*, **57**, 2172-2175.
- [219]Allen, S.L., Casper, T.A., Fenstermacher, M.E., Foote, J.H., Hooper, E.B., Hoshino, K., Lasnier, C.J., Lopez, P., Makowski, M.A., Marinak, M.M., Meyer, W.H., Moller, J.M., Oasa, K., Oda, T., Odajima, K., Ogawa, T., Ogo, T., Rice, B.W., Rognlien, T., Stallard, B.W., Thomassen, K.I., Wood, R.D., 1992, Electron cyclotron resonance heating in the microwave tokamak experiment. *Proc. 14th Int. Conf. on Plasma Physics and Controlled Nuclear Fusion Research, Würzburg, Vol. 1*, 617-625, (IAEA-CN-56/E-1-4).
- [220]Hartemann, F., Legorburu, P.P., Chu, T.S., Danly, B.G., Temkin, R.J., Faillon, G., Mourier, G., Trémeau, T., Bres, M., 1992, Long pulse high gain 35 GHz free-electron maser amplifier experiments. *Nucl. Instr. Meth.*, **A318**, 87-93.
- [221]Chu, T.S., Hartemann, F., Legorburu, P.P., Danly, B.G., Temkin, R.J., Faillon, G., Mourier, G., Trémeau, T., Bres, M., 1992, High-power millimeter-wave Bragg free-electron maser oscillator experiments. *Nucl. Instr. Meth.*, **A318**, 94-100.
- [222]Conde, M.E., Bekefi, G., 1992, Amplification and superradiant emission from a 33.3 GHz free electron laser with a reversed axial guide magnetic field. *IEEE Trans. Plasma Science*, **20**, 240-244 and *Nucl. Instr. Meth.*, **A318**, 109-113.
- [223]Volfbeyn, P., Ricci, K., Chen, B., Bekefi, G., 1994, Measurement of the temporal and spatial phase variations of a pulsed free electron laser amplifier. *IEEE Trans. Plasma Science*, **22**, 659-665.
- [224]Pasour, J.A., Gold, S.H., 1985, Free electron laser experiments with and without a guide magnetic field: a review of millimeter-wave free electron laser research at the NRL. *IEEE J. Quantum Electronics*, **21**, 845-858.
- [225]Pershing, D.E., Seeley, R.D., Jackson, R.H., Freund, H.P., 1995, Amplifier performance of the NRL ubitron. *Nucl. Instr. Meth.*, **A358**, 104-107.
- [226]Karbushev, N.I., Mirnov, P.V., Sazhin, V.D., Shatkus, A.D., 1992, Generation of microwave radiation by an intense microsecond electron beam in an axisymmetric wiggler. *Nucl. Instr. Meth.*, **A318**, 117-119.
- [227]Liu, S., 1992, Recent development of FEL research activities in P.R. China. *Conf. Digest 17th Int. Conf. on Infrared and Millimeter Waves, Pasadena, Proc., SPIE 1929*, 441 and private communication.
- [228]Chen, J., Wang, M.C., Wang, Z., Lu, Z., Zhang, L., Feng, B., 1991, Study of a Raman free-electron laser oscillator with Bragg reflection resonators. *IEEE J. Quantum Electron.*, **27**, 477-495.
- [229]Feng, B., Lu, Z., Zhang, L., Wang, M., 1994, Investigation of Raman free-electron lasers with a bifilar helical small-period wiggler. *IEEE J. Quantum Electron.*, **30**, 2682-2687.
- [230]Boehmer, H., Christensen, T., Camponi, M.Z., Hauss, B., 1990, A long-pulse millimeter-wave free electron maser experiment. *IEEE Trans. Plasma Science*, **18**, 392-398.
- [231]Shaw, A., Al-Shammaá, A., Stuart, R.A., Balfour, C., Lucas, J., 1996, First results of a CW industrial FEM, *Nucl. Instr. Meth.*, **A357**, 245-247.
- [232]Cheng, S., Granatstein, V.L., Destler, W.W., Levush, B., Rodgers, J., Antonsen, T.M., Jr., 1996, Experimental study of high-power, saturated amplification in a sheet-beam-small-period-wiggler FEL. *Nucl. Instr. Meth.*, **A357**, 160-163.
- [233]Cheng, S., Destler, W.W., Granatstein, V.L., Antonsen, T.M., Jr., Levush, B., Rodgers, J., Zhang, Z.X., 1996, A high-power millimeter-wave sheet beam free-electron laser amplifier. *IEEE Trans. on Plasma Sciences*, **24**, 750-757.
- [234]Elias, L.R., Ramian, G., Hu, J., Amir, A., 1986, Observation of single mode operation of a free electron laser. *Phys. Rev. Lett.*, **57**, 424-427.
- Ramian, G., 1992, The new UCSB free-electron lasers. *Nucl. Instr. Meth.*, **A318**, 225-229.

- [235]Cohen, M., Eichenbaum, A., Arbel, M., Ben-Haim, D., Kleinman, H., Draznin, M., Kugel, A., Yacover, I.M., Gover, A., 1995, Masing and single-mode locking in a free-electron maser employing prebunched electron beam. *Phys. Rev. Lett.*, **74**, 3812-3815 and, 1996, *Nucl. Instr. Meth.*, **A375**, 17-20.
- [236]Van der Slot, P.J.M., Wittemann, W.J., 1993, Energy and frequency measurements on the Twente Raman free-electron laser. *Nucl. Instr. Meth.*, **A331**, 140-143.